



UX SERIES

SPEC SHEET

GP40-50UXS6
Internal Combustion
Counterbalanced
Forklift

4,000 - 5,000kg

GP40-50UXS6

Features

The Yale® UX Series provides the ideal solution to meet your less frequent usage, without compromising on performance and durability.

MODEL RANGE [→](#)

The range consists of 4,000 - 5,000kg. IC counterbalance, pneumatic tyre forklift trucks, available in three different capacities (Lift and Load Centre):

4,000kg - GP40UX 4,500kg - GP45UX 5,000kg - GP50UX 5,000kg - GP50UXS6

Each model is available with diesel, LPG, or dual fuel 2 speed forward/1 reverse powershift transmission, with front-end equipment options to suit varying applications.

EASY TO OPERATE

The ergonomically designed operator's compartment, with a familiar automotive layout, means that drivers will be able to work comfortably. A range of standard features and options help the truck to be configured to the needs of the application.

SERVICEABILITY

Due to the simplicity of the components and specifications, servicing can be carried out quickly and easily.

LOW COST OF OWNERSHIP

The use of high-quality, robust components, with efficient filtration and excellent cooling contributes to reliable operations and lower wear and tear. This, together with the fast availability of cost-effective replacement parts reduces maintenance requirements and cost.

ERGONOMICS

The ergonomically designed operator compartment offers an automotive-style layout to promote operator comfort and familiarity. Tailor the truck for your application with a range of standard features and options, including an informative, 3.5-inch LCD display, generous foot space in operator compartment, dual suspension system, hand parking brake lever with button greatly reducing fatigue in operation, and a small diameter steering wheel with adjustable steering column.

SAFETY AND STABILITY

The wide view mast offers significant front field of view thus minimizing blind spots and increasing operator awareness. A high-strength, overhead guard is designed for visibility. The hand lever parking brake requires low effort and helps reduce fatigue and keep operators fresh all shift long, while the low centre of gravity to help promote stability.

EASY MAINTENANCE

You need a lift truck solution you can count on. The UX series is designed for easy serviceability, helping minimize time out of service and offer availability when you need it. Offering a large access area for service and repairs, simple components and computer-based diagnostics are not required.

RELIABILITY AND EXCHANGEABILITY

Robust components and a simple design help deliver the reliability and parts availability you expect from the Yale brand, with high-strength, triplex plate OHG and exchangeable components across 4,000 and 5,000-pound capacity models.





1 HIGH STRENGTH OHG

The overhead guard features profiled steel with high strength glass to enhance reliability and operator protection..

2 SUSPENSION SEAT

A full suspension seat that offers excellence in comfort, with an operator presence system fitted as standard.

3 WIDE VIEW MAST

The wide mast features an outside width of 720mm. It can significantly improve the driver's front field of view while increasing the safety and comfort of operating the truck.

4 LOW STEP DRIVER HEIGHT

Convenient step placing to suit a variety of heights to ensure easy access to the truck at all times.

5 SMALL STEERING WHEEL

The adjustable steering wheel is convenient for the operator as it provides 8 degrees of adjustment. It is also easy to navigate when working in narrow spaces.

6 JAPANESE ENGINE

The UX Japanese engine provides reliability and ease for sourcing replacement parts.

Engineered for drivers with comfort, safety & ergonomics



YALE DISPLAY WITH 3.5" LCD

- The Yale UX Series Forklift adopts a 3.5" LCD display, providing convenient viewing of the display data when driving and operating



HAND PARKING BRAKE

- Low effort to operate park brake lever
- Hand parking brake lever with button reduces operator fatigue



SPACIOUS FOOTWELL

- Spacious foot room design provides comfort, convenience and safety
- Control pedals provide extra foot space which reduces operator fatigue and increases operator comfort



DUAL SUSPENSION SYSTEM

- Heavy duty and robust Powershift transmission with two forward gears and one reverse
- Durable and long life Drive Axle



LARGE ACCESS AREA FOR SERVICE AND REPAIRS

- Large access space to engine compartment makes service and repairs more convenient



SUSPENSION SEAT

- Full suspension seat offers excellent comfort
- Operator presence system as standard



IMPROVED LIFTING SPEED

- Competitive lifting speeds reduces cycle time and increases productivity



HIGH STRENGTH OVERHEAD GUARD

- Profiled steel overhead guard
- High strength roof with high strength glass enhances reliability and operator protection



GOOD THROUGH-MAST VISIBILITY

- The wide view mast with an outside width of 720mm, significantly improves the driver's front field of view, reduces blind spots, and increases the safety and comfort of the operation



SMALL DIAMETER STEERING WHEEL WITH ADJUSTABLE STEER COLUMN

- The 300mm diameter steering wheel is easy to manipulate, responsive, and ensures optimum mobility when working in a narrow space
- The ideally positioned steering wheel allows 8 degrees of adjustment, to suit a variety of different operators



EXCHANGEABLE COMPONENTS

- Engine cover, instrument panel, display and most other components are exchangeable with other capacities in the same range
- Front fenders adaptable to single or dual wheel configuration

GP40-50UXS6 OPTIONS

Yale UX Series trucks feature a comprehensive range of standard equipment, with a number of options available to suit the specific needs of your application, including:

- 4th Function hydraulics (+clamping function)
- Pneumatic-shaped solid (tyres)
- Various fork lengths
- Integral sideshift
- Rear, LED work light
- Strobe light
- Backup alarm
- High air intake with pre-cleaner
- Tilt cylinder boots
- Various mast heights
- Polycarbonate top screen
- Front window with wiper
- Alternate tilt angles

Please refer to the Price List for full option configurations.



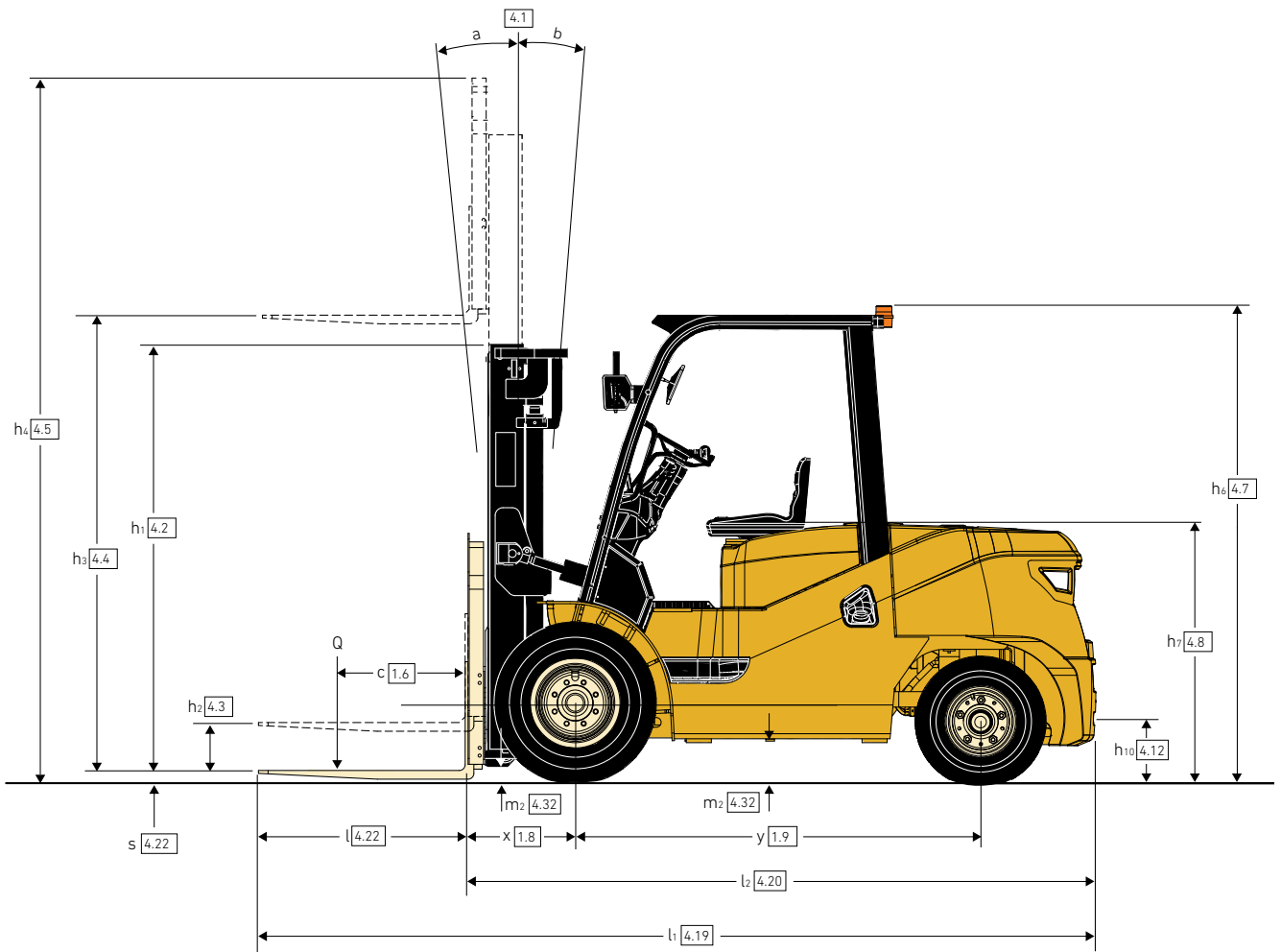

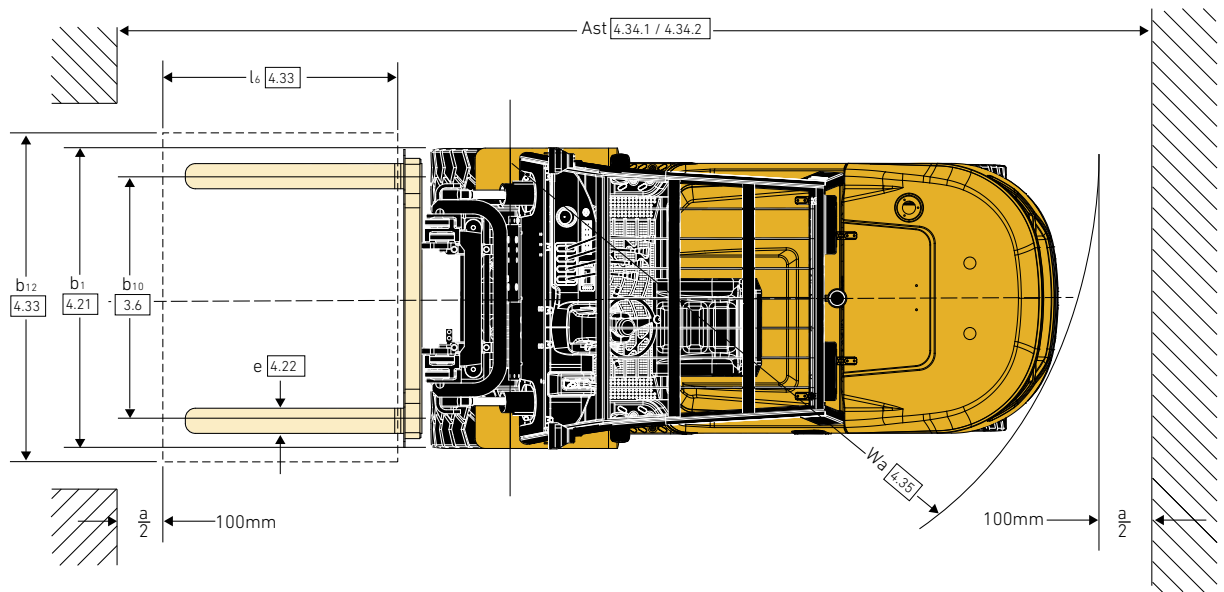

GDP40-50UX MAST DETAILS AND CAPACITY RATINGS (KG) - SUPERELASTIC TYRES

Mast Specs.	Max. Fork Lift	Overall Extended Height						Free Lift				Load Distance		Mast Tilt		Capacity 500mm Load Centre Front Single Tyre			Mast Weight
		Lowered Height		Without Load Backrest		With Load Backrest		Without Load Backrest		With Load Backrest		4.0 - 4.5t	5.0t	F	B	4.0t	4.5t	5.0t	4.0-4.5t
		4.0 - 4.5t	5.0t	4.0 - 4.5t	5.0t	4.0 - 4.5t	5.0t	4.0 - 4.5t	5.0t										
		(mm)	(mm)	(mm)	(mm)	(mm)	(mm)	(mm)	(mm)	(mm)	(mm)	mm	mm	(°)	(°)	kg	kg	kg	kg
2-STAGE LIMITED FREE-LIFT (LFL) MAST																			
M300	3000	2250	2250	3850	3850	4260	4260	150	155	150	155	575	580	6	12	4000	4500	5000	1310
M330	3300	2400	2400	4150	4150	4560	4560	150	155	150	155	575	580	6	12	4000	4500	5000	1335
M350	3500	2500	2500	4350	4350	4760	4760	150	155	150	155	575	580	6	12	4000	4500	5000	1360
M370	3700	2600	2600	4600	4600	5010	5010	150	155	150	155	575	580	6	12	4000	4500	5000	1370
M400	4000	2800	2800	4850	4850	5260	5260	150	155	150	155	575	580	6	12	3800	4250	4750	1420
M450	4500	3050	3050	5350	5350	5760	5760	150	155	150	155	575	580	6	6	3400	3800	4250	1490
M500	5000	3300	3300	5850	5850	6260	6260	150	155	150	155	575	580	6	6	2800	3150	3500	1540
M550	5500	3600	3600	6350	6350	6760	6760	150	155	150	155	575	580	3	6	2250	2800	2850	1630
M600	6000	3850	3850	6850	6850	7260	7260	150	155	150	155	575	580	3	6	1950	2500	2550	1680
2-STAGE FULL FREE-LIFT (FFL) MAST																			
M300	3000	2250	2250	3800	3800	4210	4210	1425	1425	1030	1425	585	590	6	12	4000	4500	5000	1420
M330	3300	2400	2400	4100	4100	4510	4510	1575	1575	1180	1575	585	590	6	12	3960	4460	4960	1430
M350	3500	2500	2500	4300	4300	4710	4710	1675	1675	1280	1675	585	590	6	12	3920	4420	4920	1470
M375	3750	2600	2625	4550	4550	4960	4960	1800	1800	1405	1800	585	590	6	12	3850	4350	4850	1500
M400	4000	2800	2800	4800	4800	5210	5210	1975	1975	1580	1975	585	590	6	12	3750	4250	4750	1540
3-STAGE FULL FREE-LIFT (FFL) MAST																			
TFM400	4000	2110	2110	4860	4860	5260	5260	1270	1270	885	1270	630	635	6	6	3600	4000	4500	1760
TFM435	4350	2235	2235	5210	5210	5610	5610	1395	1395	1010	1395	630	635	6	6	3400	3800	4250	1800
TFM450	4500	2285	2285	5360	5360	5760	5760	1445	1445	1060	1445	630	635	6	6	3200	3600	4000	1820
TFM480	4800	2385	2385	5660	5660	6060	6060	1545	1545	1160	1545	630	635	6	6	3000	3350	3750	1860
TFM500	5000	2485	2485	5860	5860	6260	6260	1645	1645	1260	1645	630	635	6	6	2800	3150	3500	1900
TFM540	5400	2610	2610	6260	6260	6660	6660	1770	1770	1380	1770	630	635	3	6	2250	2550	2850	1940
TFM600	6000	2850	2850	6860	6860	7260	7260	2010	2010	1625	2010	630	635	3	6	1950	1950	2200	2090
TFM650	6500	3050	3050	7360	7360	7760	7760	2210	2210	1825	2210	630	635	3	6	1500	1500	1700	2240

Capacities are with standard carriage.

GDP50UXS6 MAST DETAILS AND CAPACITY RATINGS (KG) - SUPERELASTIC TYRES

Mast Specs.	Max. Fork Lift	Overall Extended Height			Free Lift		Load Distance	Mast Tilt		Capacity 600mm Load Centre		Mast Weight
		Lowered Height	Without Load Backrest	With Load Backrest	Without Load Backrest	With Load Backrest		Front Single Tyres	Front Dual Tyres			
		5t @ 600mm	5t @ 600mm	5t @ 600mm	5t @ 600mm	5t @ 600mm		5t @ 600mm	5t @ 600mm			
		(mm)	(mm)	(mm)	(mm)	(mm)		(mm)	(mm)	F	B	
2-STAGE LIMITED FREE-LIFT (LFL) MAST												
M300	3000	2250	3855	4420	160	160	585	6	12	5000	5000	1440
M330	3300	2400	4155	4720	160	160	585	6	12	5000	5000	1465
M350	3500	2500	4355	4920	160	160	585	6	12	5000	5000	1490
M370	3700	2600	4605	5170	160	160	585	6	12	5000	5000	1500
M400	4000	2800	4855	5420	160	160	585	6	12	4750	5000	1550
M450	4500	3050	5355	5920	160	160	585	6	6	4250	4550	1620
M500	5000	3300	5855	6420	160	160	585	6	6	3500	3750	1670
M550	5500	3600	6355	6920	160	160	585	3	6	2850	3350	1760
M600	6000	3850	6855	7420	160	160	585	3	6	2550	2950	1810
2-STAGE FULL FREE-LIFT (FFL) MAST												
M300	3000	2250	3855	4410	1435	875	595	6	12	5000	5000	1550
M330	3300	2400	4155	4710	1585	1025	595	6	12	5000	5000	1580
M350	3500	2500	4355	4910	1685	1125	595	6	12	5000	5000	1600
M375	3750	2625	4605	5160	1810	1250	595	6	12	5000	5000	1630
M400	4000	2800	4855	5410	1985	1425	595	6	12	4750	5000	1670
3-STAGE FULL FREE-LIFT (FFL) MAST												
TFM400	4000	2110	4880	5425	1285	735	640	6	6	4500	4750	1890
TFM435	4350	2235	5230	5775	1405	860	640	6	6	4250	4500	1930
TFM450	4500	2285	5385	5930	1460	910	640	6	6	4000	4250	1950
TFM480	4800	2385	5680	6230	1555	1010	640	6	6	3750	4000	1990
TFM500	5000	2485	5880	6425	1655	1110	640	6	6	3400	3650	2030
TFM540	5400	2610	6280	6820	1780	1235	640	3	6	2850	3350	2070
TFM600	6000	2850	6875	7420	2020	1475	640	3	6	2200	2950	2220
TFM650	6500	3050	7375	7920	2220	1675	640	3	6	1700	2650	2370

Capacities are with standard carriage.

MITSUBISHI 5.0L DIESEL

- 6 Cylinder
- Displacement
- Torque
- Power
- Air filtration
- IDI fuel injection system
- Overhead Valve
- 4.996 litre
- 250Nm @ 1,600rpm
- 52kW @ 2,300rpm
- Two stage, dry type

KUBOTA 3.8L DIESEL

- 4 Cylinder
- Displacement
- Torque
- Power
- Air filtration
- Overhead Valve
- 3.769 litre
- 308Nm @ 1,500rpm
- 55.4kW @ 2,200rpm
- Two stage, dry type

KUBOTA 3.8L LPG

- 4 Cylinder
- Displacement
- Torque
- Power
- Air filtration
- IDI fuel injection system
- Overhead Valve
- 3.769 litre
- 300Nm @ 1,200rpm
- 63.2kW @ 2,400rpm
- Two stage, dry type

KUBOTA 3.8L DUAL FUEL

- 4 Cylinder
- Displacement
- Torque
- Power
- Air filtration
- IDI fuel injection system
- Overhead Valve
- 3.769 litre
- 300Nm @ 1,200rpm
- 57.6kW @ 2,400rpm
- Two stage, dry type

GENERAL SPECIFICATIONS - GP40UX

DISTINGUISHING MARK	1.1	Manufacturer	Yale					
	1.2	Model designation	GDP40UX	GLP40UX	GTP40UX	GLP40UX		
	1.3	Drive: electric(battery or mains), diesel, petrol, fuel gas	Diesel	Diesel Stage V	Dual fuel	LPG		
	1.4	Operator type: hand, pedestrian, standing, seated, order-picker	Seated					
	1.5	Rated capacity/rated load	kg	4000				
	1.6	Load centre distance	mm	500				
	1.8	Load distance, centre of drive axle to fork	mm	575				
	1.9	Wheelbase (with mast vertical)	mm	2100				
	WEIGHT	2.1	Service weight	kg	6435			
2.2		Axle loading, laden front/rear	kg	9195/1240				
2.3		Axle loading, unladen front/rear	kg	3075/3360				
TYRES/CHASSIS	3.1	Tyres: Solid rubber, superelastic, pneumatic, polyurethane	Pneumatic					
	3.2	Tyre size, front	300-15-18PR					
	3.3	Tyre size, rear	7.00-12-12PR					
	3.5	wheels, number front/rear	2X2					
	3.6	Tread, front	mm	1190				
	3.7	Tread, rear	mm	1130				
	DIMENSIONS	4.1	Tilt of mast/fork carriage, forward /backward	α / β (°)	6/12			
4.2		Height, mast lowered	mm	2250				
4.3		Free lift	mm	150				
4.4		Lift	mm	3000				
4.5		Height, mast extended	mm	4260				
4.7		Height of overhead guard(cabin)	mm	2250 (2400)				
4.8		Seat height/stand height	mm	1350				
4.12		Towing coupling height	mm	340				
4.19		Overall length	mm	4280				
4.20		Length to face of forks	mm	3210				
4.21		Overall width, Std/Dual	mm	1490/1924				
4.22		Fork dimensions ISO2331	mm	50/150/1070				
4.23		Fork carriage ISO 2328. Class/type, A/B	ISO 3A					
4.24		Fork carriage width	mm	1380				
4.31		Ground clearance, laden, below mast	mm	155/130				
4.32		Ground clearance, centre of wheelbase	mm	186				
4.33		Load dimension b 12*/6 crossways	1000x1000					
4.34		Aisle width with predetermined load dimensions	mm	4695				
4.34.1		Aisle width with pallets 1000mm x 1200mm crossways	mm	4825				
4.34.2		Aisle width with pallets 800mm x 1200mm crossways	mm	4825				
4.35	Turning radius	mm	2850					
4.36	Internal turning radius	b ₁₃	845					
PERFORMANCE DATA	5.1	Travel speed, laden/unladen	km/h	Shift 2: 24/25 Shift 1: 17/18	Shift 2: 22/24 Shift 1: 15/16	Shift 2: 25/28 Shift 1: 18/19	Shift 2: 26/28 Shift 1: 18/19	
	5.1.1	Travel speed, laden/unladen, backwards	km/h	Shift 1:19/20	Shift 1:17/19	Shift 1:21/22		
	5.2	Lifting speed, laden/unladen	mm/s	530/560				
	5.3	Lowering speed laden/unladen	mm/s	480/500				
	5.6	Max. drawbar pull laden/unladen	N	30000/23000	25000/21000	31500/30000	33000/32000	
	5.7	Gradeability, laden/unladen	%	24/25	20/25	24/25	25/25	
	5.9	Acceleration time, laden/unladen	sec	with load: 5.05(S1) / 4.76(S2) without load: 4.15(S1) / 3.95(S2)	TBC	with load: 5.07(S1) / 4.78(S2) without load: 4.15(S1) / 3.95(S2)		
	5.10	Service brake	Hydraulic					
	COMBUSTION-ENGINE	7.1	Engine manufacturer/type	Mitsubishi S6S	Kubota V3800-CR-TE5CB-HYM-1	Kubota WG3800-GL-C	Kubota WG3800-L-C	
		7.2	Engine power according to DIN ISO 1585	kW	52	55.4	57.6	63.2
7.3		Rated speed	min ⁻¹	2300	2200	2400		
7.4		Number of cylinders/displacement	-/cm ³	6/4996	4/3769			
7.5		Fuel consumption according to VDI cycle	l/h or kg/h	7.02l/h or 5.9kg/h	TBC	6.15kg/h	6.24kg/h	
7.6		Turnover output	t/h	270t/h	TBC	280t/h	286t/h	
7.7		Energy consumption at turnover output	l/h or kg/h	9.26l/h or 7.77kg/h	TBC	7.93kg/h	8.16kg/h	
7.8		Generator	A	35	100			
7.9		Vehicle electrical system voltage	V	24	12			
7.10		Battery voltage/nominal capacity	V/Ah	2-12/60	12/120	12/90		
ADDITIONAL DATA	8.1	Type of drive unit	E-Hydraulic					
	10.1	Operating pressure for attachments	bar	195				
	10.2	Oil volume for attachments	l/min	70				
	10.4	Fuel tank capacity	L	100				
	10.7	Sound pressure level at the driver's seat	dB (A)	88	81.5	88		
	10.7.1	Sound power level during the work cycle	dB (A)	109.6	99.7	109.6		
	10.8	Towing coupling, type DIN	PIN					

GENERAL SPECIFICATIONS - GP45UX

DISTINGUISHING MARK	1.1	Manufacturer	Yale					
	1.2	Model designation	GDP45UX	GLP45UX	GTP45UX	GLP45UX		
	1.3	Drive: electric(battery or mains), diesel, petrol, fuel gas	Diesel	Diesel Stage V	Dual fuel	LPG		
	1.4	Operator type: hand, pedestrian, standing, seated, order-picker	Seated					
	1.5	Rated capacity/rated load	kg	4500				
	1.6	Load centre distance	mm	500				
	1.8	Load distance, centre of drive axle to fork	mm	575				
	1.9	Wheelbase (with mast vertical)	mm	2100				
	WEIGHT	2.1	Service weight	kg	6670			
2.2		Axle loading, laden front/rear	kg	9917/1253				
2.3		Axle loading, unladen front/rear	kg	2910/3760				
TYRES/CHASSIS	3.1	Tyres: Solid rubber, superelastic, pneumatic, polyurethane	Pneumatic					
	3.2	Tyre size, front	300-15-18PR					
	3.3	Tyre size, rear	7.00-12-12PR					
	3.5	wheels, number front/rear	2X2					
	3.6	Tread, front	mm	1190				
	3.7	Tread, rear	mm	1130				
	DIMENSIONS	4.1	Tilt of mast/fork carriage, forward /backward	α / β (°)	6/12			
4.2		Height, mast lowered	mm	2250				
4.3		Free lift	mm	150				
4.4		Lift	mm	3000				
4.5		Height, mast extended	mm	4260				
4.7		Height of overhead guard(cabin)	mm	2250 (2400)				
4.8		Seat height/stand height	mm	1350				
4.12		Towing coupling height	mm	340				
4.19		Overall length	mm	4280				
4.20		Length to face of forks	mm	3210				
4.21		Overall width, Std/Dual	mm	1490/1924				
4.22		Fork dimensions ISO2331	mm	50/150/1070				
4.23		Fork carriage ISO 2328. Class/type, A/B	ISO 3A					
4.24		Fork carriage width	mm	1380				
4.31		Ground clearance, laden, below mast	mm	155/130				
4.32		Ground clearance, centre of wheelbase	mm	186				
4.33		Load dimension b 12*/6 crossways	1000x1000					
4.34		Aisle width with predetermined load dimensions	mm	4695				
4.34.1		Aisle width with pallets 1000mm x 1200mm crossways	mm	4825				
4.34.2		Aisle width with pallets 800mm x 1200mm crossways	mm	4825				
4.35		Turning radius	mm	2850				
4.36	Internal turning radius	b ₁₃	845					
PERFORMANCE DATA	5.1	Travel speed, laden/unladen	km/h	Shift 2: 24/25 Shift 1: 17/18	Shift 2: 22/24 Shift 1: 15/16	Shift 2: 25/28 Shift 1: 18/19	Shift 2: 26/28 Shift 1: 18/19	
	5.1.1	Travel speed, laden/unladen, backwards	km/h	Shift 1:19/20	Shift 1:17/19	Shift 1:21/22		
	5.2	Lifting speed, laden/unladen	mm/s	530/560				
	5.3	Lowering speed laden/unladen	mm/s	480/500				
	5.6	Max. drawbar pull laden/unladen	N	30000/23000	25000/21000	31500/30000	33000/32000	
	5.7	Gradeability, laden/unladen	%	22/25	20/25	23/25		
	5.9	Acceleration time, laden/unladen	sec	with load: 5.21(S1) / 4.86(S2) without load: 4.32(S1) / 4.15(S2)	TBC	with load: 5.29(S1) / 4.93(S2) without load: 4.32(S1) / 4.15(S2)		
	5.10	Service brake	Hydraulic					
	COMBUSTION-ENGINE	7.1	Engine manufacturer/type	Mitsubishi S6S	Kubota V3800-CR-TE5CB-HYM-1	Kubota WG3800-GL-C	Kubota WG3800-L-C	
		7.2	Engine power according to DIN ISO 1585	kW	52	55.4	57.6	63.2
7.3		Rated speed	min ⁻¹	2300	2200	2400		
7.4		Number of cylinders/displacement	-/cm ³	6/4996	4/3769			
7.5		Fuel consumption according to VDI cycle	l/h or kg/h	7.26l/h or 6.1kg/h	TBC	6.5kg/h	6.85kg/h	
7.6		Turnover output	t/h	300t/h	TBC	310t/h	317t/h	
7.7		Energy consumption at turnover output	l/h or kg/h	9.62l/h or 8.07kg/h	TBC	8.27kg/h	8.36kg/h	
7.8		Generator	A	35	100			
7.9		Vehicle electrical system voltage	V	24	12			
7.10		Battery voltage/nominal capacity	V/Ah	2-12/60	12/120	12/90		
ADDITIONAL DATA	8.1	Type of drive unit	E-Hydraulic					
	10.1	Operating pressure for attachments	bar	195				
	10.2	Oil volume for attachments	l/min	70				
	10.4	Fuel tank capacity	L	100				
	10.7	Sound pressure level at the driver's seat	dB (A)	88	81.5	88		
	10.7.1	Sound power level during the work cycle	dB (A)	109.6	99.7	109.6		
	10.8	Towing coupling, type DIN	PIN					

GENERAL SPECIFICATIONS - GP50UX

DISTINGUISHING MARK	1.1	Manufacturer	Yale					
	1.2	Model designation	GDP50UX	GLP50UX	GTP50UX	GLP50UX		
	1.3	Drive: electric(battery or mains), diesel, petrol, fuel gas	Diesel	Diesel Stage V	Dual fuel	LPG		
	1.4	Operator type: hand, pedestrian, standing, seated, order-picker	Seated					
	1.5	Rated capacity/rated load	kg	5000				
	1.6	Load centre distance	mm	500				
	1.8	Load distance, centre of drive axle to fork	mm	580				
	1.9	Wheelbase (with mast vertical)	mm	2100				
	WEIGHT	2.1	Service weight	kg	7010			
2.2		Axle loading, laden front/rear	kg	10810/1200				
2.3		Axle loading, unladen front/rear	kg	3160/3850				
TYRES/CHASSIS	3.1	Tyres: Solid rubber, superelastic, pneumatic, polyurethane	Pneumatic					
	3.2	Tyre size, front	300-15-18PR					
	3.3	Tyre size, rear	7.00-12-12PR					
	3.5	wheels, number front/rear	2X2					
	3.6	Tread, front	mm	1190				
	3.7	Tread, rear	mm	1130				
	DIMENSIONS	4.1	Tilt of mast/fork carriage, forward /backward	α / β (°)	6/12			
4.2		Height, mast lowered	mm	2250				
4.3		Free lift	mm	155				
4.4		Lift	mm	3000				
4.5		Height, mast extended	mm	4260				
4.7		Height of overhead guard(cabin)	mm	2250 (2400)				
4.8		Seat height/stand height	mm	1350				
4.12		Towing coupling height	mm	340				
4.19		Overall length	mm	4345				
4.20		Length to face of forks	mm	3275				
4.21		Overall width, Std/Dual	mm	1490/1924				
4.22		Fork dimensions ISO2331	mm	50/150/1070				
4.23		Fork carriage ISO 2328. Class/type, A/B	ISO 3A					
4.24		Fork carriage width	mm	1380				
4.31		Ground clearance, laden, below mast	mm	155/130				
4.32		Ground clearance, centre of wheelbase	mm	186				
4.33		Load dimension b 12*/6 crossways	1000x1000					
4.34		Aisle width with predetermined load dimensions	mm	4755				
4.34.1		Aisle width with pallets 1000mm x 1200mm crossways	mm	4885				
4.34.2		Aisle width with pallets 800mm x 1200mm crossways	mm	4885				
4.35	Turning radius	mm	2905					
4.36	Internal turning radius	b ₁₃	845					
PERFORMANCE DATA	5.1	Travel speed, laden/unladen	km/h	Shift 2: 25/27 Shift 1: 17/18	Shift 2: 22/24 Shift 1: 15/16	Shift 2: 25/28 Shift 1: 18/19	Shift 2: 26/28 Shift 1: 18/19	
	5.1.1	Travel speed, laden/unladen, backwards	km/h	Shift 1:19/20	Shift 1:17/19	Shift 1:21/22		
	5.2	Lifting speed, laden/unladen	mm/s	530/560				
	5.3	Lowering speed laden/unladen	mm/s	480/500				
	5.6	Max. drawbar pull laden/unladen	N	30000/23000	25000/21000	31500/30000	33000/32000	
	5.7	Gradeability, laden/unladen	%	20/25	21/25	20/25	25/25	
	5.9	Acceleration time, laden/unladen	sec	with load: 5.41(S1) / 5.06(S2) without load: 4.52(S1) / 4.35(S2)	with load: 5.24(S1) / 5.34(S2) without load: 4.82(S1) / 4.50(S2)	with load: 5.55(S1) / 5.19(S2) without load: 4.52(S1) / 4.35(S2)		
	5.10	Service brake	Hydraulic					
	COMBUSTION-ENGINE	7.1	Engine manufacturer/type	Mitsubishi S6S	Kubota V3800-CR-TE5CB-HYM-1	Kubota WG3800-GL-C	Kubota WG3800-L-C	
		7.2	Engine power according to DIN ISO 1585	kW	52	55.4	57.6	63.2
7.3		Rated speed	min ⁻¹	2300	2200	2400		
7.4		Number of cylinders/displacement	-/cm ³	6/4996	4/3769			
7.5		Fuel consumption according to VDI cycle	l/h or kg/h	7.62l/h or 6.4kg/h	5l/h / 4.2kg/h	6.9kg/h	7.44kg/h	
7.6		Turnover output	t/h	345t/h	375t/h	346t/h		
7.7		Energy consumption at turnover output	l/h or kg/h	9.97l/h or 8.37kg/h	8.93l/h / 7.5kg/h	8.46kg/h	8.52kg/h	
7.8		Generator	A	35	100			
7.9		Vehicle electrical system voltage	V	24	12			
7.10		Battery voltage/nominal capacity	V/Ah	2-12/60	12/120	12/90		
ADDITIONAL DATA	8.1	Type of drive unit	E-Hydraulic					
	10.1	Operating pressure for attachments	bar	195				
	10.2	Oil volume for attachments	l/min	70				
	10.4	Fuel tank capacity	L	100				
	10.7	Sound pressure level at the driver's seat	dB (A)	88	81.5	88		
	10.7.1	Sound power level during the work cycle	dB (A)	109.6	99.7	109.6		
	10.8	Towing coupling, type DIN	PIN					

GENERAL SPECIFICATIONS - GP50UXS6

DISTINGUISHING MARK	1.1	Manufacturer	Yale					
	1.2	Model designation	GDP50UXS6	GLP50UXS6	GTP50UXS6	GLP50UXS6		
	1.3	Drive: electric(battery or mains), diesel, petrol, fuel gas	Diesel	Diesel Stage V	Dual fuel	LPG		
	1.4	Operator type: hand, pedestrian, standing, seated, order-picker	Seated					
	1.5	Rated capacity/rated load	kg	5000				
	1.6	Load centre distance	mm	600				
	1.8	Load distance, centre of drive axle to fork	mm	585				
	1.9	Wheelbase (with mast vertical)	mm	2100				
	WEIGHT	2.1	Service weight	kg	7260			
2.2		Axle loading, laden front/rear	kg	10910/1350				
2.3		Axle loading, unladen front/rear	kg	3270/3990				
TYRES/CHASSIS	3.1	Tyres: Solid rubber, superelastic, pneumatic, polyurethane	Pneumatic					
	3.2	Tyre size, front	300-15-18PR					
	3.3	Tyre size, rear	7.00-12-14PR					
	3.5	wheels, number front/rear	2X2					
	3.6	Tread, front	mm	1190				
	3.7	Tread, rear	mm	1130				
	DIMENSIONS	4.1	Tilt of mast/fork carriage, forward /backward	α / β (°)	6/12			
4.2		Height, mast lowered	mm	2250				
4.3		Free lift	mm	160				
4.4		Lift	mm	3000				
4.5		Height, mast extended	mm	4420				
4.7		Height of overhead guard(cabin)	mm	2250 (2400)				
4.8		Seat height/stand height	mm	1350				
4.12		Towing coupling height	mm	340				
4.19		Overall length	mm	4530				
4.20		Length to face of forks	mm	3310				
4.21		Overall width, Std/Dual	mm	1490/1924				
4.22		Fork dimensions ISO2331	mm	60/150/1220				
4.23		Fork carriage ISO 2328. Class/type, A/B	ISO 4A					
4.24		Fork carriage width	mm	1380				
4.31		Ground clearance, laden, below mast	mm	130				
4.32		Ground clearance, centre of wheelbase	mm	186				
4.33		Load dimension b 12*/6 crossways	1000x1000					
4.34		Aisle width with predetermined load dimensions	mm	4935				
4.34.1		Aisle width with pallets 1000mm x 1200mm crossways	mm	4935				
4.34.2		Aisle width with pallets 800mm x 1200mm crossways	mm	4935				
4.35	Turning radius	mm	2930					
4.36	Internal turning radius	b ₁₃	845					
PERFORMANCE DATA	5.1	Travel speed, laden/unladen	km/h	Shift 2: 25/27 Shift 1: 17/18	Shift 2: 22/24 Shift 1: 15/16	Shift 2: 25/28 Shift 1: 18/19	Shift 2: 26/28 Shift 1: 18/19	
	5.1.1	Travel speed, laden/unladen, backwards	km/h	Shift 1:19/20	Shift 1:17/19	Shift 1:21/22		
	5.2	Lifting speed, laden/unladen	mm/s	530/560				
	5.3	Lowering speed laden/unladen	mm/s	500/450				
	5.6	Max. drawbar pull laden/unladen	N	30000/23000	25000/21000	31500/30000	33000/32000	
	5.7	Gradeability, laden/unladen	%	20/25		21/25	20/25	
	5.9	Acceleration time, laden/unladen	sec	with load: 5.41(S1) / 5.06(S2) without load: 4.52(S1) / 4.35(S2)	with load: 5.24(S1) / 5.34(S2) without load: 4.82(S1) / 4.50(S2)	with load: 5.55(S1) / 5.19(S2) without load: 4.52(S1) / 4.35(S2)		
	5.10	Service brake	Hydraulic					
	COMBUSTION-ENGINE	7.1	Engine manufacturer/type	Mitsubishi S6S	Kubota V3800-CR-TE5CB-HYM-1	Kubota WG3800-GL-C	Kubota WG3800-L-C	
		7.2	Engine power according to DIN ISO 1585	kW	52	55.4	57.6	63.2
7.3		Rated speed	min ⁻¹	2300	2200	2400		
7.4		Number of cylinders/displacement	-/cm ³	6/4996	4/3769			
7.5		Fuel consumption according to VDI cycle	l/h or kg/h	7.62l/h or 6.4kg/h	5l/h / 4.2kg/h	6.9kg/h	7.44kg/h	
7.6		Turnover output	t/h	345t/h	375t/h	345t/h		
7.7		Energy consumption at turnover output	l/h or kg/h	9.97l/h or 8.37kg/h	8.93l/h / 7.5kg/h	8.46kg/h	8.52kg/h	
7.8		Generator	A	35	100			
7.9		Vehicle electrical system voltage	V	24	12			
7.10		Battery voltage/nominal capacity	V/Ah	2-12/60	12/120	12/90		
ADDITIONAL DATA	8.1	Type of drive unit	E-Hydraulic					
	10.1	Operating pressure for attachments	bar	195				
	10.2	Oil volume for attachments	l/min	70				
	10.4	Fuel tank capacity	L	100				
	10.7	Sound pressure level at the driver's seat	dB (A)	88	81.5	87.5		
	10.7.1	Sound power level during the work cycle	dB (A)	109.6	99.7	107		
	10.8	Towing coupling, type DIN	PIN					

About Yale



Yale Lift Truck Technologies leverages over a century of material handling experience and substantial investment in innovation to bring the most advanced technology-driven lift truck solutions to market. The company offers a full line of award-winning lift trucks, including reach trucks, order pickers, turret trucks, pallet jacks and trucks, pallet stackers, tow tractors and counterbalanced forklifts, as well as powerful operator assist solutions, proven robotics and a wide range of power sources to help customers adapt to today's demanding supply chain. Yale and its independent dealer network support these solutions with comprehensive after-sales service, parts, financing and training.

Yale Lift Truck Technologies is a trading name of Hyster-Yale Asia-Pacific Pty Ltd., a wholly owned subsidiary of Hyster-Yale Materials Handling, Inc. (NYSE:HY) which is headquartered in Cleveland, Ohio and operates globally.

MATERIALS HANDLING FOR:

3PL

Auto Parts Distribution

Beverage

Cold & Frozen Foods

Food Distribution

Food Processing

Furniture & Furnishings

Government

Health & Pharma

Home Centers

Retail & E-commerce

Yale Pacific

1/23 Rowood Road, Prospect NSW 2148

Tel: +61 (2) 9795 3800 | Fax: +61 (2) 9792 8484

Yale Asia

16 Tuas Avenue 20, Singapore 638827

Tel: +65 6863 3387 | Fax: +65 6863 3349

yale.com

© 2023 Hyster-Yale Group, Inc., all rights reserved. YALE and  are trademarks of Hyster-Yale Group, Inc. Trucks may be shown with optional equipment and/or features not available in all regions. Specifications and details in this brochure are subject to change without prior notification.