



# UX SERIES

BROCHURE

MS15UX  
Electric Walkie  
Stacker

---

1,500kg

# MS15UX

The Yale® walkie stacker MS15UX helps the operator increase productivity, while providing operator comfort and serviceability. It allows various performance modes and valuable features to increase operator productivity.

## PRODUCTIVITY

- Maintenance free AC motor
- Multi-function display with BDI and hour meter
- Emergency reversing button
- Auto deceleration function
- Low speed switch
- Variable speed control
- Sideways battery removal with rollers
- Mast cushioning for low-noise operation
- Built-in pressure relief valve protects from overloads
- Emergency power disconnect switch
- Cold store configuration (option)

## OPTIMUM STRUCTURAL DESIGN

- Low centre of gravity enhances stability
- Full free lift mast options for low overhead clearance
- Durable plastic covers
- Adjustable balance casters improve stability

## SERVICEABILITY

- Low voltage protection setting extends the battery life
- CANbus technology
- Simple electronic components makes troubleshooting and servicing more efficient
- Hall effect sensors reduce wear and increase component life



Handle (Standard)  
(Left & Right Handed)



Fork Lengths to Suit  
All Applications



One Sided (Cold Store)



Two Sided (Cold Store)

# LOAD CHARTS

## LOAD CENTRE CHART

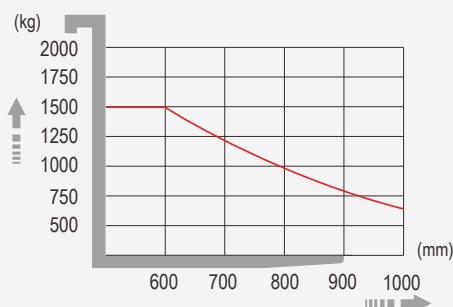

## LOAD CAPACITY CHART

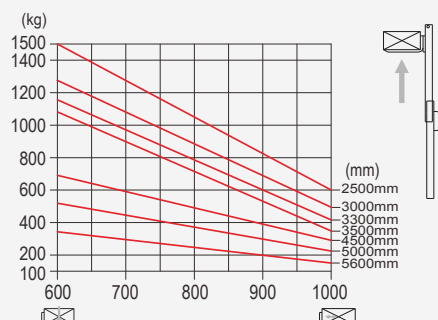

## SPECIFICATIONS AND DIMENSIONS

Model	Measurement	MS15UX						
Load capacity	Q (kg)	1500						
Load centre distance	c (mm)	600						
Load distance, centre of drive axle to fork	x (mm)	697						
Wheelbase	y (mm)	1410						
Fork height, lowered	h13 (mm)	90						
Tyre size, front	mm	250x70						
Tyre size, rear	mm	80x84						
Additional wheels (dimensions)	mm	150x60						
Wheels, number front rear (x=driven wheels)		1x+1/4						
Height, mast lowered	h1 (mm)	1735	1985	2135	2235	2050	2210	2410
Free lift (option 2500-3500mm)	h2 (mm)	0	0	0	0	1570	1740	1940
Max. lift height	h3 (mm)	2500	3000	3300	3500	4500	5000	5600
Height, mast extended	h4 (mm)	2955	3455	3755	3955	5030	5510	6110
Height of tiller in drive position min./max.	h14 (mm)	670/1300						
Overall length	l1 (mm)	1950						
Length to face of forks	l2 (mm)	878						
Overall width	b1 (mm)	820						
Fork dimensions	s/e/l (mm)	60/180/1070 (1150)						
Width overall forks	b5 (mm)	570/695						
Aisle width for pallets 800x1200 lengthways	Ast (mm)	2420						
Turning radius	Wa (mm)	1575						
Drive motor power	kW	1.2						
Lift motor power	kW	3						
Sound level at the driver's ear according to DIN12503	dB (A)	70						
Travel speed, laden/unladen	Km/h	5.8/6						
Lift speed, laden/unladen	m/s	0.11/0.15						
Lowering speed, laden/unladen	m/s	0.12/0.12						
Battery voltage, nominal capacity K (Duplex Mast)	V/Ah	24/240						
Battery voltage, nominal capacity K (Triplex Mast)	V/Ah	24/240						
Battery weight	Kg	220						
Battery dimensions l/w/h	mm	625x254x500						
Service weight (with battery)	Kg	1140/1190/1200/1290/1370/1400/1530						

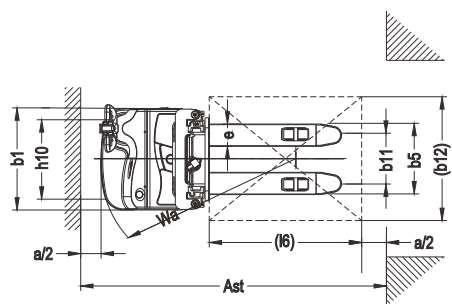
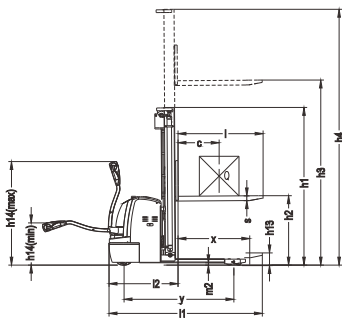

## MS15UX POWER PLUG TYPE



**A**  
Power Plug



**F**  
Power Plug



**G**  
Power Plug



**I**  
Power Plug

# About Yale



Yale Lift Truck Technologies leverages over a century of material handling experience and substantial investment in innovation to bring the most advanced technology-driven lift truck solutions to market. The company offers a full line of award-winning lift trucks, including reach trucks, order pickers, turret trucks, pallet jacks and trucks, pallet stackers, tow tractors and counterbalanced forklifts, as well as powerful operator assist solutions, proven robotics and a wide range of power sources to help customers adapt to today's demanding supply chain. Yale and its independent dealer network support these solutions with comprehensive after-sales service, parts, financing and training.

Yale Lift Truck Technologies is a trading name of Hyster-Yale Asia-Pacific Pty Ltd., a wholly owned subsidiary of Hyster-Yale Materials Handling, Inc. (NYSE:HY) which is headquartered in Cleveland, Ohio and operates globally.

## MATERIALS HANDLING FOR:

3PL

Auto Parts Distribution

Beverage

Cold & Frozen Foods

Food Distribution

Food Processing

Furniture & Furnishings

Government

Health & Pharma

Home Centers

Retail & E-commerce

Yale Pacific

1/23 Rowood Road, Prospect NSW 2148

Tel: +61 (2) 9795 3800 | Fax: +61 (2) 9792 8484

Yale Asia

16 Tuas Avenue 20, Singapore 638827

Tel: +65 6863 3387 | Fax: +65 6863 3349

**[yale.com](http://yale.com)**

© 2023 Hyster-Yale Group, Inc., all rights reserved. YALE and  are trademarks of Hyster-Yale Group, Inc. Trucks may be shown with optional equipment and/or features not available in all regions. Specifications and details in this brochure are subject to change without prior notification.