



UX SERIES

BROCHURE

MP20XUX
Electric Walkie
Pallet Truck

2,000kg

MP20XUX

The Yale® electric rider pallet truck MP20XUX delivers low cost of ownership, as well as boosting pallet transportation rates over both short and long distances. These sturdy trucks can optimise vehicle loading and unloading operations while providing the operator with optimum comfort.

PRODUCTIVITY

- Advanced AC control system eliminates the motor brushes, which limits maintenance requirements
- Low skirtings on main chassis
- Side battery roll-out system is very convenient to replace batteries
- Built-in pressure relief valve protects the trucks from overloading
- Emergency power disconnect switch
- Long handle reduces steering effort
- Emergency reversing system in handle
- Low speed switch in the handle
- Variable speed control
- Cold store configuration (option)

OPTIMUM STRUCTURAL DESIGN

- Spring-loaded casters improve lateral stability on uneven floors and enhance truck performance and service life
- Formed heavy gauge steel provides maximum fork strength and longevity
- Pull rod design protects against bending
- Durable plastic covers

SERVICEABILITY

- CANbus technology reduces wiring complexity
- Low battery protection setting extends the battery life
- All pivot points have grease fittings and serviceable bushing, reducing component wear



Handle (Standard)
(Left & Right Handed)



Entry Roller for
Easy Operation



One Sided
(Cold Store)



Two Sided
(Cold Store)

SPECIFICATIONS AND DIMENSIONS

| Model | Measurement | MP20XUX |
|---|-------------|-------------------------|
| Load capacity | Q (kg) | 2000 |
| Load centre distance | c (mm) | 600 |
| Load distance, centre of drive axle to fork | x (mm) | 815/865/935 |
| Wheelbase | y (mm) | 1261 |
| Fork height, lowered | h13 (mm) | 82 |
| Tyre size, front | mm | 250×70 |
| Tyre size, rear | mm | 82×126 (98) |
| Additional wheels (dimensions) | mm | 127×57 |
| Wheels, number front rear (x=driven wheels) | | 1X+2/2 (4) |
| Max.lift height | h3 (mm) | 202 |
| Height of tiller in drive position min./max. | h14 (mm) | 1150/1430 |
| Overall length | l1 (mm) | 1710/1760/1830 |
| Length to face of forks | l2 (mm) | 610 |
| Overall width | b1 (mm) | 775 |
| Fork dimensions | s/e/l (mm) | 53×180×1100 (1150/1220) |
| Width overall forks | b5 (mm) | 550/685 |
| Aisle width for pallets 1000×1200 crossways | Ast (mm) | 1910/1960/2030 |
| Aisle width for pallets 800×1200 crossways | Ast (mm) | 2010/2010/2030 |
| Turning radius | Wa (mm) | 1550/1600/1670 |
| Drive motor power | kW | 1.2 |
| Lift motor power | kW | 0.8 |
| Sound level at the driver's ear according to DIN12503 | dB (A) | 70 |
| Travel speed, laden/unladen | Km/h | 7/7.1 |
| Battery voltage, nominal capacity K5 | V/Ah | 24/210 |
| Battery weight | Kg | 196 |
| Battery dimensions l/w/h | mm | 750×170×534 |
| Service weight (with battery) | Kg | 720 |

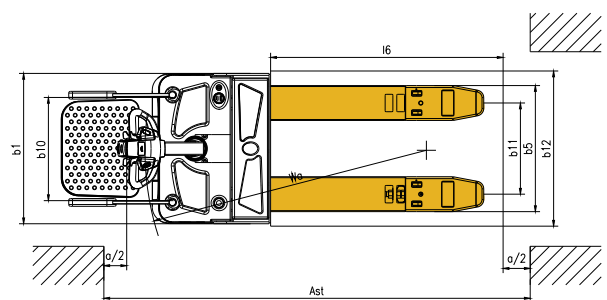
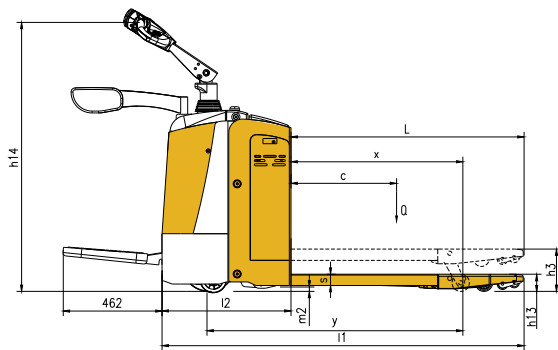

MP20XUX POWER PLUG TYPE



A
Power Plug



F
Power Plug



G
Power Plug

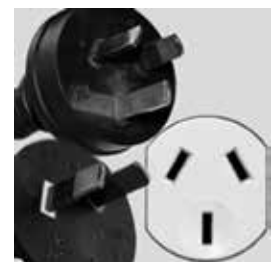

I
Power Plug

About Yale



Yale Lift Truck Technologies leverages over a century of material handling experience and substantial investment in innovation to bring the most advanced technology-driven lift truck solutions to market. The company offers a full line of award-winning lift trucks, including reach trucks, order pickers, turret trucks, pallet jacks and trucks, pallet stackers, tow tractors and counterbalanced forklifts, as well as powerful operator assist solutions, proven robotics and a wide range of power sources to help customers adapt to today's demanding supply chain. Yale and its independent dealer network support these solutions with comprehensive after-sales service, parts, financing and training.

Yale Lift Truck Technologies is a trading name of Hyster-Yale Asia-Pacific Pty Ltd., a wholly owned subsidiary of Hyster-Yale Materials Handling, Inc. (NYSE:HY) which is headquartered in Cleveland, Ohio and operates globally.

MATERIALS HANDLING FOR:

3PL

Auto Parts Distribution

Beverage

Cold & Frozen Foods

Food Distribution

Food Processing

Furniture & Furnishings

Government

Health & Pharma

Home Centers

Retail & E-commerce

Yale Pacific

1/23 Rowood Road, Prospect NSW 2148

Tel: +61 (2) 9795 3800 | Fax: +61 (2) 9792 8484

Yale Asia

16 Tuas Avenue 20, Singapore 638827

Tel: +65 6863 3387 | Fax: +65 6863 3349

yale.com

© 2023 Hyster-Yale Group, Inc., all rights reserved. YALE and  are trademarks of Hyster-Yale Group, Inc. Trucks may be shown with optional equipment and/or features not available in all regions. Specifications and details in this brochure are subject to change without prior notification.