Yale UX Series

Electric Rider Pallet Truck

MP20XUX / 2000kg



www.yale.com.au

Yale[®] 
People. Products. Productivity.™

► Overview

MP20XUX

The Yale® electric rider pallet truck MP20XUX delivers low cost of ownership, as well as boosting pallet transportation rates over both short and long distances. These sturdy trucks can optimise vehicle loading and unloading operations while providing the operator with optimum comfort.

► Productivity

- Advanced AC control system eliminates the motor brushes, which limits maintenance requirements
- Low skirtings on main chassis
- Side battery roll-out system is very convenient to replace batteries
- Built-in pressure relief valve protects the trucks from overloading
- Emergency power disconnect switch
- Long handle reduces steering effort
- Emergency reversing system in handle
- Low speed switch in the handle
- Variable speed control
- Cold store configuration (option)

► Optimum Structural Design

- Spring-loaded casters improve lateral stability on uneven floors and enhance truck performance and service life
- Formed heavy gauge steel provides maximum fork strength and longevity
- Pull rod design protects against bending
- Durable plastic covers

► Serviceability

- CANbus technology reduces wiring complexity
- Low battery protection setting extends the battery life
- All pivot points have grease fittings and serviceable bushing, reducing component wear



Handle (Standard)
(Left & Right Handed)



Entry Roller for
Easy Operation



One Sided
(Cold Store)



Two Sided
(Cold Store)

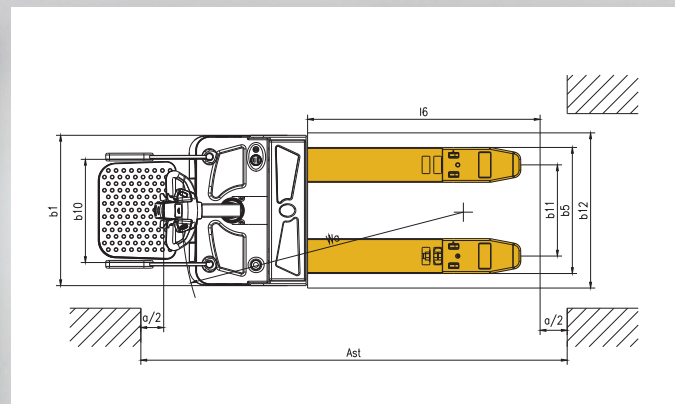
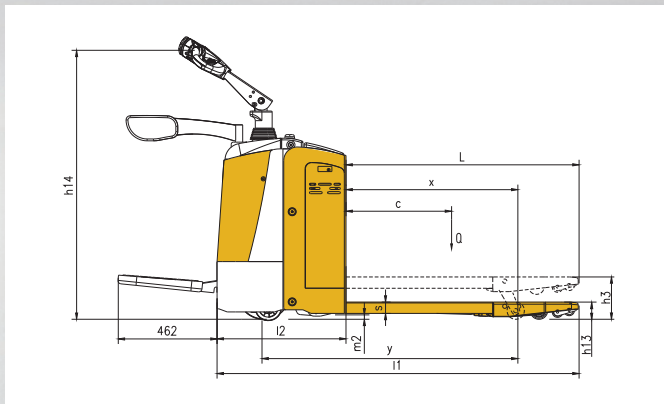

Model	Measurement	MP20XUX
Load capacity	Q (kg)	2000
Load centre distance	c (mm)	600
Load distance, centre of drive axle to fork	x (mm)	815/865/935
Wheelbase	y (mm)	1261
Fork height, lowered	h13 (mm)	82
Tyre size, front	mm	250×70
Tyre size, rear	mm	82×126 (98)
Additional wheels (dimensions)	mm	127×57
Wheels, number front rear (x=driven wheels)		1X+2/2 (4)
Max. lift height	h3 (mm)	202
Height of tiller in drive position min./max.	h14 (mm)	1150/1430
Overall length	l1 (mm)	1710/1760/1830
Length to face of forks	l1 (mm)	610
Overall width	b1 (mm)	775
Fork dimensions	s/e/l (mm)	53×180×1100 (1150/1220)
Width overall forks	b5 (mm)	550/685
Aisle width for pallets 1000×1200 crossways	Ast (mm)	1910/1960/2030
Aisle width for pallets 800×1200 crossways	Ast (mm)	2010/2010/2030
Turning radius	Wa (mm)	1550/1600/1670
Drive motor power	kW	1.2
Lift motor power	kW	0.8
Sound level at the driver's ear according to DIN12503	dB (A)	70
Travel speed, laden/unladen	Km/h	7/7.1
Battery voltage, nominal capacity K5	V/Ah	24/210
Battery weight	kg	196
Battery dimensions l/w/h	mm	750×170×534
Service weight (with battery)	kg	720

▶ MP20XUX Power Plug Type

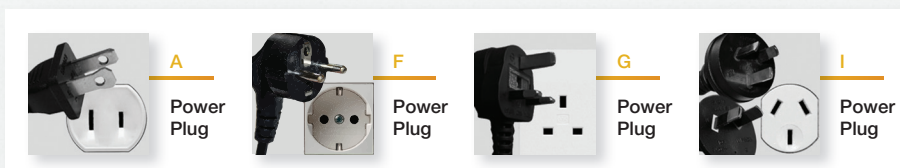

Yale® Dealers



Contact your nearest
Yale® Dealership by visiting
www.yale.com.au

Contact your local Yale® Dealer

Yale Pacific

1 Bullecourt Avenue, Milperra NSW, Australia 2214
Tel: +61 (2) 9795 3800 | Fax: +61 (2) 9792 8484
yale.com/pacific/en-au

Yale Asia

16 Tuas Avenue 20, Singapore 638827
Tel: +65 6863 3387 | Fax: +65 6863 3349
yale.com/asia/en-sg

Yale, and PEOPLE. PRODUCTS. PRODUCTIVITY are trademarks of Hyster-Yale Group, Inc.
® is a registered copyright of Hyster-Yale Group, Inc.

©Yale Asia Pacific 2020. All rights reserved. Specifications and details in this brochure are subject to change without prior notification.

www.yale.com.au



Manufactured in our own ISO 9001 and 14001 Registered Facilities

Trucks may be shown with optional equipment.

Yale® 
People. Products. Productivity.™

BR0000070 REV 02/20