



# ERC 2.2-3.5VG2

SPEC SHEET

Cushion tire electric  
counterbalanced  
forklift

---

2,200-3,500 kg

# TRUCK DIMENSIONS

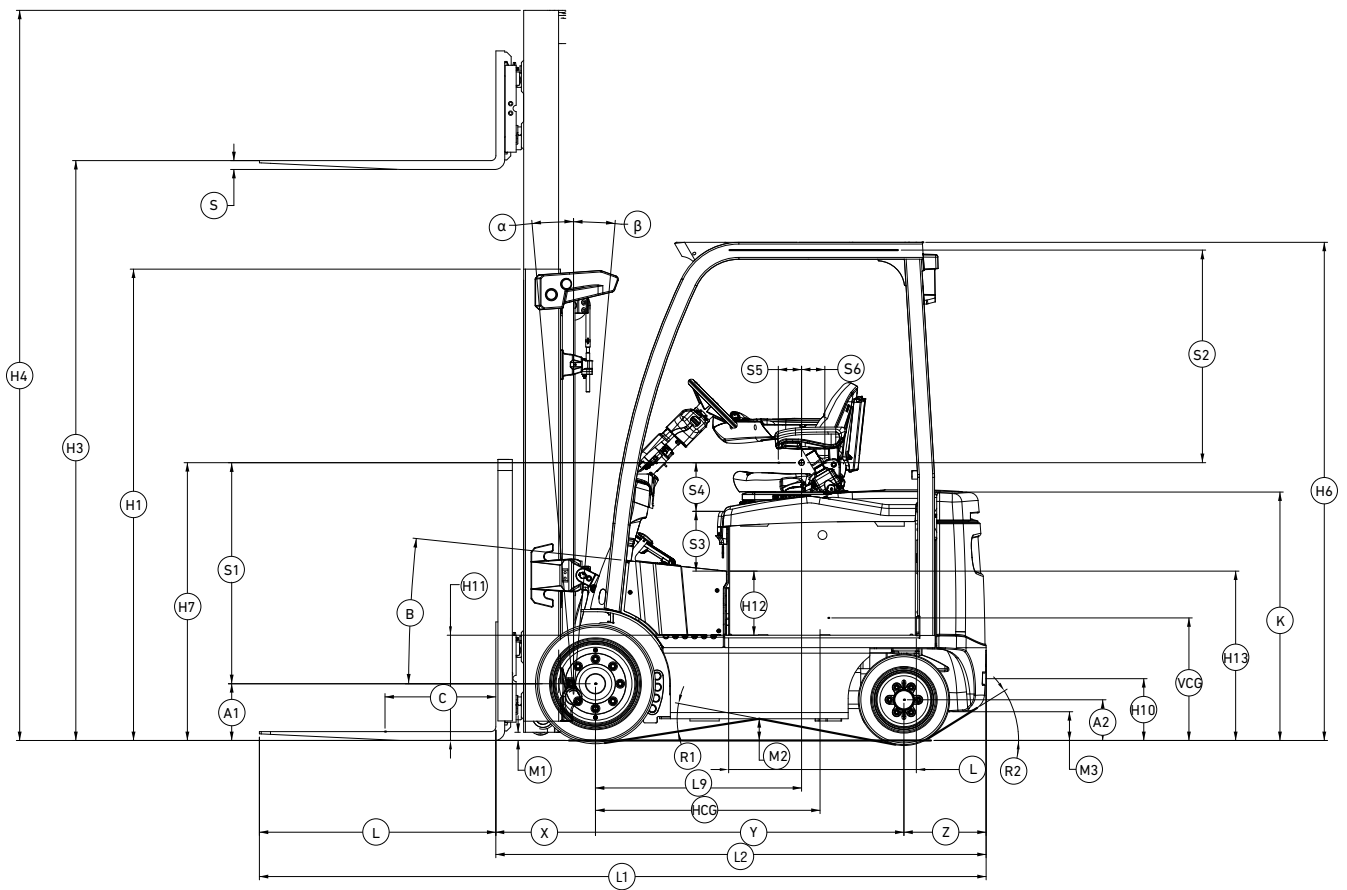
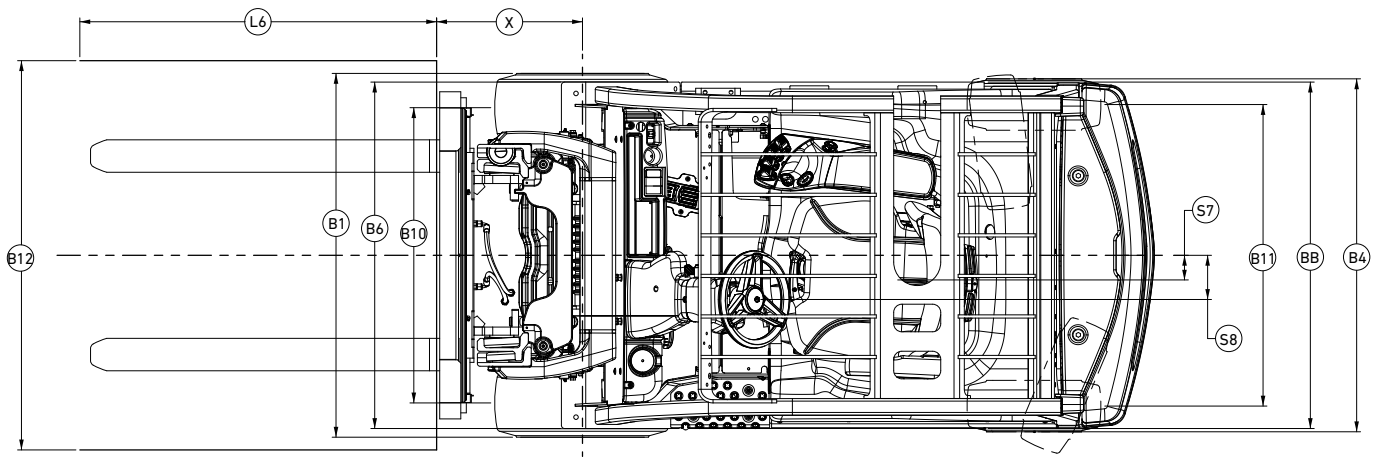

Circled dimensions correspond to the line numbers on the tabulated chart inside the spec sheet. Dimensions are in inches (millimeters).

## GENERAL SPECIFICATIONS

GENERAL	1-1	Manufacturer			Yale			
	1-2	Model designation			ERC2.2VG2			
	1-2-1	Model			Standard			
	1-3	Drive: electric (battery or mains), diesel, petrol, LPG			Electric (battery)			
	1-4	Operator type: hand, pedestrian, standing, seated, order-picker			Seated			
	1-5	Rated capacity/rated load	Q	kg	2200			
	1-6	Load centre distance	c	mm	600			
	1-8	Load distance, centre of drive axle to fork	x	mm	425			
		Battery Compartment Width		mm	992			
		Battery Compartment Height		mm	607 / 594			
	Nominal Battery Compartment		mm	700	786	847		
	Actual Battery Compartment		mm	700	786	847		
1-9	Wheelbase	y	mm	1245	1331	1392		
WEIGHT	2-1	Service weight (1)		kg	4791	4712	4906	
	2-2	Axle loading laden, front/rear (1)		kg	5726 / 1264	5632/1121	5745 / 1361	
	2-3	Axle loading unladen, front/rear (1)		kg	1894 / 2897	2006/2707	2085 / 2821	
WHEELS	6-5	Battery weight (min/max)		kg	1050/1500	1150/1600	1320/1770	
	3-1	Tyres, front/rear			Cushion, smooth			
	3-2	Tyre size, front		in	21 x 7 x 15			
	3-3	Tyre size, rear		in	16 x 5 x 10.5			
	3-5	Number of wheels, front/rear (X = driven)			2x / 2			
	3-6	Tread, front *	b10	mm	883			
3-7	Tread, rear	β11	mm	945				
4-1	Tilt of mast / fork carriage forward / backward	/	(o)	5 / 5				
4-2	Height, mast lowered	h1	mm	2129				
4-3	Free lift (2)	h2	mm	100				
4-4	Lift (2)	h3	mm	3220				
4-5	Height, mast extended (3)	h4	mm	3260				
4-7	Height of overhead guard (4)	h6	mm	2248				
4-8	Seat height relating to SIP/stand height (5)	h7	mm	1254				
4-12	Coupling height	h10	mm	279				
4-19	Overall length	l1	mm	3108	3184	3245		
4-20	Length to face of forks (6)	l2	mm	2041	2117	2178		
4-21	Overall width *	b1	mm	1068				
4-22	Fork dimensions DIN ISO 2331	s/e/l	mm	40 x 100 x 1067				
4-23	Fork carriage ISO 2328, class/type A, B			II A				
4-24	Fork carriage width (7)	b3	mm	977				
4-31	Ground clearance, laden, below mast	m1	mm	37				
4-32	Ground clearance, centre of wheelbase	m2	mm	98				
4-33	Load dimensions b12 x l6 crossways	b12/l6	mm	1200 x 1000				
4-34-1	Aisle width for pallets 1000 x 1200 crossways	Ast	mm	3353	3400	3457		
4-34-2	Aisle width for pallets 800 x 1200 lengthways	Ast	mm	3508	3557	3615		
4-35	Turning radius	Wa	mm	1669	1720	1779		
4-36	Internal turning radius	b13	mm	186	198	208		
4-41	90° intersecting aisle (with pallet W = 1200mm, L = 1000mm)	W2	mm	1810	1831	1855		
4-42	Step height (from ground to running board) (9)		mm	475	475	475		
4-43	Step height (between intermediate steps between running board and floor)		mm	289	289	289		
PERFORMANCE	8-1	Drive control			Intelmatch		Duramatch	
	6-4	Battery voltage/nomical capacity K5		V / Ah	AC induction		Permanent magnet	
					36	48	48	80
	5-1	Travel speed, laden/unladen, Extended shift off (10)		km/h	17.0/17.5	18.2/17.7	19.9/19.5	20.1/19.7
	5-1-1	Travel speed, laden/unladen, Extended shift on (10)		km/h	16.9/17.4	18.2/17.7	19.9/19.5	20.1/19.6
	5-2	Lift speed, laden/unladen, 2-stg LFL		m/s	0.6/0.65	0.61/0.65	0.66/0.67	0.65/0.67
	5-2-1	Lift speed, laden/unladen, 2-stg FFL		m/s	0.55/0.6	0.56/0.6	0.61/0.62	0.6/0.62
	5-2-2	Lift speed, laden/unladen, 3-stg FFL		m/s	0.57/0.61	0.58/0.61	0.62/0.63	0.62/0.63
	5-2-3	Lift speed, laden/unladen, 4-stg FFL		m/s	0.54/0.58	0.55/0.58	0.59/0.6	0.6/0.6
	5-3	Lowering speed, laden/unladen, 2-stg LFL		m/s	0.55/0.65			
	5-3-1	Lowering speed, laden/unladen, 2-stg FFL		m/s	0.5/0.6			
	5-3-2	Lowering speed, laden/unladen, 3-stg FFL		m/s	0.52/0.61			
	5-3-3	Lowering speed, laden/unladen, 4-stg FFL		m/s	0.39/0.45			
	5-5	Drawbar pull, laden / unladen, 60 minute rating **		N	8150/8660	8700/9220	15210/15830	15470/15850
	5-6	Maximum drawbar pull, laden / unladen, 5 minute rating ***		N	16320/16960	16660/17300	19330/20010	25330/25710
	5-7	Gradeability, laden / unladen, 30 minute rating **** (11)		%	17/25	16/25	28/25	29/25
	5-8	Maximum gradability, laden / unladen, *** (11)		%	25/25	26/25	30/25	41/25
	Gradeability, laden / unladen, 60 minute rating		%	12/20	13/21	23/25	24/25	
5-9	Acceleration time, laden/unladen, 15m (10)		s	5.6/5.4	5.6/5.3	5.5/5.1	5.2/4.8	
5-10	Service brake			Wet disc - oil immersed				
ELECTRIC DRIVE	6-1	Drive motor rating S2 60 min		kW	2x 8.8		2x 12	
	6-2	Lift motor rating at S3 15%		kW	20.1		21.5	
ADDITIONAL DATA	6-6	Energy consumption according to DIN EN 16796 (12)		kWh/h	3.3	5.6	4.8	5.2
	10-1	Operating pressure for attachments		bar	180			
	10-2	Oil volume for attachments (13)		l/min	40			
	10-3	Hydraulic oil tank, capacity		l	21.2			
	10-7	Sound pressure level at the driver's seat (14)		dB (A)	71			
10-8	Towing coupling, type DIN			Pin				

## GENERAL SPECIFICATIONS

				Yale				
GENERAL	1-1	Manufacturer		ERC2.5VG2				
	1-2	Model designation		Standard				
	1-2-1	Model		Electric (battery)				
	1-3	Drive: electric (battery or mains), diesel, petrol, LPG		Seated				
	1-4	Operator type: hand, pedestrian, standing, seated, order-picker		2500				
	1-5	Rated capacity/rated load	Q	kg	600			
	1-6	Load centre distance	c	mm	425			
	1-8	Load distance, centre of drive axle to fork	x	mm	992			
		Battery Compartment Width		mm	607 / 594			
		Battery Compartment Height		mm	700	786	847	
	Nominal Battery Compartment		mm	700	786	847		
	Actual Battery Compartment		mm	1245	1331	1392		
1-9	Wheelbase	y	mm	4962	4875	4863		
WEIGHT	2-1	Service weight (1)		kg	6148 / 1314	5957/1186	6239 / 1123	
	2-2	Axle loading laden, front/rear (1)		kg	1793 / 3162	1928/2947	2080 / 2783	
	2-3	Axle loading unladen, front/rear (1)		kg	1050/1500	1150/1600	1320/1770	
WHEELS	6-5	Battery weight (min/max)		kg	Cushion, smooth			
	3-1	Tyres, front/rear			21 x 7 x 15			
	3-2	Tyre size, front		in	16 x 5 x 10.5			
	3-3	Tyre size, rear		in	2x / 2			
	3-5	Number of wheels, front/rear (X = driven)			883			
	3-6	Tread, front *		mm	945			
DIMENSIONS	3-7	Tread, rear	β10	mm	5 / 5			
	4-1	Tilt of mast / fork carriage forward / backward	/	(o)	2129			
	4-2	Height, mast lowered	h1	mm	100			
	4-3	Free lift (2)	h2	mm	3220			
	4-4	Lift (2)	h3	mm	3260			
	4-5	Height, mast extended (3)	h4	mm	2248			
	4-7	Height of overhead guard (4)	h6	mm	1254			
	4-8	Seat height relating to SIP/stand height (5)	h7	mm	279			
	4-12	Coupling height	h10	mm	3108			
	4-19	Overall length	l1	mm	3184	3245		
	4-20	Length to face of forks (6)	l2	mm	2041	2178		
	4-21	Overall width *	b1	mm	1068			
	4-22	Fork dimensions DIN ISO 2331	s/e/l	mm	40 x 100 x 1067			
	4-23	Fork carriage ISO 2328, class/type A, B			II A			
	4-24	Fork carriage width (7)	b3	mm	977			
	4-31	Ground clearance, laden, below mast	m1	mm	37			
	4-32	Ground clearance, centre of wheelbase	m2	mm	98			
	4-33	Load dimensions b12 x l6 crossways	b12/l6	mm	1200 x 1000			
	4-34-1	Aisle width for pallets 1000 x 1200 crossways	Ast	mm	3382	3433	3457	
	4-34-2	Aisle width for pallets 800 x 1200 lengthways	Ast	mm	3537	3590	3615	
	4-35	Turning radius	Wa	mm	1698	1753	1779	
	4-36	Internal turning radius	b13	mm	186	198	208	
	4-41	90° intersecting aisle (with pallet W = 1200mm, L = 1000mm)	W2	mm	1821	1843	1855	
	4-42	Step height (from ground to running board) (9)		mm	475	475	475	
4-43	Step height (between intermediate steps between running board and floor)		mm	289	289	289		
PERFORMANCE	8-1	Drive control			Intelimatch		Duramatch	
	6-4	Battery voltage/nominal capacity K5		V / Ah	AC induction		Permanent magnet	
	5-1	Travel speed, laden/unladen, Extended shift off (10)		km/h	36	48	48	80
	5-1-1	Travel speed, laden/unladen, Extended shift on (10)		km/h	16.8/17.4	18.2/17.7	19.9/19.5	20.1/19.7
	5-2	Lift speed, laden/unladen, 2-stg LFL		m/s	16.9/17.4	18.2/17.7	19.9/19.5	20.1/19.6
	5-2-1	Lift speed, laden/unladen, 2-stg FFL		m/s	0.57/0.65	0.57/0.65	0.62/0.67	0.61/0.67
	5-2-2	Lift speed, laden/unladen, 3-stg FFL		m/s	0.52/0.6	0.53/0.6	0.57/0.62	0.57/0.62
	5-2-3	Lift speed, laden/unladen, 4-stg FFL		m/s	0.53/0.61	0.54/0.61	0.59/0.63	0.58/0.63
	5-3	Lowering speed, laden/unladen, 2-stg LFL		m/s	0.51/0.58	0.51/0.58	0.55/0.6	0.56/0.6
	5-3-1	Lowering speed, laden/unladen, 2-stg FFL		m/s	0.55/0.65			
	5-3-2	Lowering speed, laden/unladen, 3-stg FFL		m/s	0.5/0.6			
	5-3-3	Lowering speed, laden/unladen, 4-stg FFL		m/s	0.52/0.61			
	5-5	Drawbar pull, laden / unladen, 60 minute rating **		N	8090/8650	8630/9210	15150/15820	15410/15840
	5-6	Maximum drawbar pull, laden / unladen, 5 minute rating ***		N	16260/16950	16600/17290	19270/20000	25270/25700
	5-7	Gradeability, laden / unladen, 30 minute rating **** (11)		%	16/26	15/25	26/27	27/27
	5-8	Maximum gradability, laden / unladen, *** (11)		%	24/27	24/27	29/27	39/27
	5-9	Gradeability, laden / unladen, 60 minute rating		%	12/19	12/21	22/27	23/27
5-9	Acceleration time, laden/unladen, 15m (10)		s	5.7/5.4	5.6/5.3	5.5/5.1	5.3/4.8	
5-10	Service brake			Wet disc - oil immersed				
ELECTRIC DRIVE	6-1	Drive motor rating S2 60 min		kW	2x 8.8		2x 12	
	6-2	Lift motor rating at S3 15%		kW	20.1		21.5	
ADDITIONAL DATA	6-6	Energy consumption according to DIN EN 16796 (12)		kWh/h	3.5	5.9	5.5	5.5
	10-1	Operating pressure for attachments		bar	180			
	10-2	Oil volume for attachments (13)		l/min	40			
	10-3	Hydraulic oil tank, capacity		l	21.2			
	10-7	Sound pressure level at the driver's seat (14)		dB (A)	71			
10-8	Towing coupling, type DIN			Pin				

## GENERAL SPECIFICATIONS

GENERAL	1-1	Manufacturer				Yale		
	1-2	Model designation				ERC2.7VG2		
	1-2-1	Model				Standard		
	1-3	Drive: electric (battery or mains), diesel, petrol, LPG				Electric (battery)		
	1-4	Operator type: hand, pedestrian, standing, seated, order-picker				Seated		
	1-5	Rated capacity/rated load	Q	kg		2700		
	1-6	Load centre distance	c	mm		600		
	1-8	Load distance, centre of drive axle to fork	x	mm		425		
		Battery Compartment Width		mm		992		
		Battery Compartment Height		mm		607 / 594		
	Nominal Battery Compartment		mm		847			
	Actual Battery Compartment		mm		847			
WEIGHT	1-9	Wheelbase	y	mm		1392		
	2-1	Service weight (1)		kg		5071		
	2-2	Axle loading laden, front/rear (1)		kg		6358/1207		
WHEELS	2-3	Axle loading unladen, front/rear (1)		kg		2011/3060		
	6-5	Battery weight (min/max)		kg		1320/1770		
	3-1	Tyres, front/rear				Cushion, smooth		
	3-2	Tyre size, front		in		21 x 8 x 15		
	3-3	Tyre size, rear		in		16 x 6 x 10.5		
	3-5	Number of wheels, front/rear (X = driven)				2x / 2		
	3-6	Tread, front *	b10	mm		908		
DIMENSIONS	3-7	Tread, rear	β11	mm		936		
	4-1	Tilt of mast / fork carriage forward / backward	/	(o)		5 / 5		
	4-2	Height, mast lowered	h1	mm		2229		
	4-3	Free lift (2)	h2	mm		100		
	4-4	Lift (2)	h3	mm		3220		
	4-5	Height, mast extended (3)	h4	mm		3260		
	4-7	Height of overhead guard (4)	h6	mm		2248		
	4-8	Seat height relating to SIP/stand height (5)	h7	mm		1254		
	4-12	Coupling height	h10	mm		279		
	4-19	Overall length	l1	mm		3245		
	4-20	Length to face of forks (6)	l2	mm		2178		
	4-21	Overall width *	b1	mm		1068		
	4-22	Fork dimensions DIN ISO 2331	s/e/l	mm		40 x 100 x 1067		
	4-23	Fork carriage ISO 2328, class/type A, B				II A		
	4-24	Fork carriage width (7)	b3	mm		977		
	4-31	Ground clearance, laden, below mast	m1	mm		37		
	4-32	Ground clearance, centre of wheelbase	m2	mm		98		
	4-33	Load dimensions b12 x l6 crossways	b12/l6	mm		1200 x 1000		
	4-34-1	Aisle width for pallets 1000 x 1200 crossways	Ast	mm		3490		
	4-34-2	Aisle width for pallets 800 x 1200 lengthways	Ast	mm		3648		
	4-35	Turning radius	Wa	mm		1812		
	4-36	Internal turning radius	b13	mm		208		
	4-41	90° intersecting aisle (with pallet W = 1200mm, L = 1000mm)	W2	mm		1887		
	4-42	Step height (from ground to running board) (9)		mm		475		
	4-43	Step height (between intermediate steps between running board and floor)		mm		289		
	PERFORMANCE	8-1	Drive control			Intelimatch		Duramatch
		6-4	Battery voltage/nominal capacity K5	V / Ah		AC induction		Permanent magnet
					36	48	48	80
5-1		Travel speed, laden/unladen, Extended shift off (10)		km/h	16.6/17.1	18.2/17.7	19.9/19.5	20.1/19.7
5-1-1		Travel speed, laden/unladen, Extended shift on (10)		km/h	16.3/17.0	18.2/17.7	19.9/19.5	20.1/19.6
5-2		Lift speed, laden/unladen, 2-stg LFL		m/s	0.53/0.65	0.54/0.65	0.58/0.67	0.58/0.67
5-2-1		Lift speed, laden/unladen, 2-stg FFL		m/s	0.49/0.6	0.5/0.6	0.53/0.62	0.53/0.62
5-2-2		Lift speed, laden/unladen, 3-stg FFL		m/s	0.5/0.61	0.51/0.61	0.55/0.63	0.54/0.63
5-2-3		Lift speed, laden/unladen, 4-stg FFL		m/s	0.39/0.58	0.48/0.58	0.52/0.6	0.55/0.6
5-3		Lowering speed, laden/unladen, 2-stg LFL		m/s			0.55/0.65	
5-3-1		Lowering speed, laden/unladen, 2-stg FFL		m/s			0.5/0.6	
5-3-2		Lowering speed, laden/unladen, 3-stg FFL		m/s			0.52/0.61	
5-3-3		Lowering speed, laden/unladen, 4-stg FFL		m/s			0.39/0.45	
5-5		Drawbar pull, laden / unladen, 60 minute rating **	N		8010/8620	8560/9180	15080/15790	15340/15810
5-6		Maximum drawbar pull, laden / unladen, 5 minute rating ***	N		19270/20000	16520/17260	19200/19980	25200/25670
5-7		Gradeability, laden / unladen, 30 minute rating **** (11)	%		15/25	14/24	24/25	25/25
5-8		Maximum gradability, laden / unladen, *** (11)	%		23/25	23/25	27/25	36/25
	Gradeability, laden / unladen, 60 minute rating	%		12/20	12/20	21/25	21/25	
5-9	Acceleration time, laden/unladen, 15m (10)	s		5.7/5.4	5.7/5.3	5.6/5.1	5.3/4.9	
5-10	Service brake			Wet disc - oil immersed				
ELECTRIC DRIVE	6-1	Drive motor rating S2 60 min		kW	2x 8.8		2x 12	
	6-2	Lift motor rating at S3 15%		kW	20.1		21.5	
ADDITIONAL DATA	6-6	Energy consumption according to DIN EN 16796 (12)		kWh/h	4.1	6.2	5.7	5.9
	10-1	Operating pressure for attachments		bar	180			
	10-2	Oil volume for attachments (13)		l/min	40			
	10-3	Hydraulic oil tank, capacity		l	21.2			
	10-7	Sound pressure level at the driver's seat (14)		dB (A)	71			
10-8	Towing coupling, type DIN			Pin				

## GENERAL SPECIFICATIONS

GENERAL	1-1	Manufacturer				Yale		
	1-2	Model designation				ERC3.0VG2		
	1-2-1	Model				Standard		
	1-3	Drive: electric (battery or mains), diesel, petrol, LPG				Electric (battery)		
	1-4	Operator type: hand, pedestrian, standing, seated, order-picker				Seated		
	1-5	Rated capacity/rated load	Q	kg		3000		
	1-6	Load centre distance	c	mm		600		
	1-8	Load distance, centre of drive axle to fork	x	mm		435		
		Battery Compartment Width		mm		992		
		Battery Compartment Height		mm		607 / 594		
	Nominal Battery Compartment		mm		847			
	Actual Battery Compartment		mm		847			
	1-9	Wheelbase	y	mm		1392		
WEIGHT	2-1	Service weight (1)		kg		5367		
	2-2	Axle loading laden, front/rear (1)		kg		7028 / 1339		
	2-3	Axle loading unladen, front/rear (1)		kg		2014 / 3353		
WHEELS	6-5	Battery weight (min/max)		kg		1320/1770		
	3-1	Tyres, front/rear				Cushion, smooth		
	3-2	Tyre size, front		in		21 x 8 x 15		
	3-3	Tyre size, rear		in		16 x 6 x 10.5		
	3-5	Number of wheels, front/rear (X = driven)				2x / 2		
	3-6	Tread, front *	b10	mm		908		
DIMENSIONS	3-7	Tread, rear	β11	mm		936		
	4-1	Tilt of mast / fork carriage forward / backward	a / b	(o)		5 / 5		
	4-2	Height, mast lowered	h1	mm		2230		
	4-3	Free lift (2)	h2	mm		100		
	4-4	Lift (2)	h3	mm		3028		
	4-5	Height, mast extended (3)	h4	mm		3280		
	4-7	Height of overhead guard (4)	h6	mm		2248		
	4-8	Seat height relating to SIP/stand height (5)	h7	mm		1254		
	4-12	Coupling height	h10	mm		279		
	4-19	Overall length	l1	mm		3269		
	4-20	Length to face of forks (6)	l2	mm		2202		
	4-21	Overall width *	b1	mm		1068		
	4-22	Fork dimensions DIN ISO 2331	s/e/l	mm		40 x 100 x 1067		
	4-23	Fork carriage ISO 2328, class/type A, B				II A		
	4-24	Fork carriage width (7)	b3	mm		977		
	4-31	Ground clearance, laden, below mast	m1	mm		37		
	4-32	Ground clearance, centre of wheelbase	m2	mm		98		
	4-33	Load dimensions b12 x l6 crossways	b12/l6	mm		1200 x 1000		
	4-34-1	Aisle width for pallets 1000 x 1200 crossways	Ast	mm		3530		
	4-34-2	Aisle width for pallets 800 x 1200 lengthways	Ast	mm		3688		
	4-35	Turning radius	Wa	mm		1842		
	4-36	Internal turning radius	b13	mm		1332		
	4-41	90° intersecting aisle (with pallet W = 1200mm, L = 1000mm)	W2	mm		1902		
	4-42	Step height (from ground to running board) (9)		mm		475		
	4-43	Step height (between intermediate steps between running board and floor)		mm		289		
	PERFORMANCE	8-1	Drive control			Intelimatch		Duramatch
		6-4	Battery voltage/nominal capacity K5		V / Ah	AC induction		Permanent magnet
5-1		Travel speed, laden/unladen, Extended shift off (10)		km/h	16.4/16.6	18.2/17.7	19.9/19.5	20.1/19.7
5-1-1		Travel speed, laden/unladen, Extended shift on (10)		km/h	15.9/16.5	18.2/17.7	19.9/19.5	20.1/19.6
5-2		Lift speed, laden/unladen, 2-stg LFL		m/s	0.44/0.62	0.45/0.62	0.48/0.64	0.48/0.64
5-2-1		Lift speed, laden/unladen, 2-stg FFL		m/s	0.42/0.58	0.42/0.58	0.46/0.6	0.45/0.6
5-2-2		Lift speed, laden/unladen, 3-stg FFL		m/s	0.42/0.6	0.43/0.6	0.46/0.62	0.46/0.62
5-2-3		Lift speed, laden/unladen, 4-stg FFL		m/s	0.39/0.58	0.4/0.58	0.43/0.6	0.42/0.6
5-3		Lowering speed, laden/unladen, 2-stg LFL		m/s	0.48/0.52			
5-3-1		Lowering speed, laden/unladen, 2-stg FFL		m/s	0.45/0.49			
5-3-2		Lowering speed, laden/unladen, 3-stg FFL		m/s	0.46/0.5			
5-3-3		Lowering speed, laden/unladen, 4-stg FFL		m/s	0.39/0.45			
5-5		Drawbar pull, laden / unladen, 60 minute rating **		N	7920/8570	8470/9130	14980/15740	15240/15760
5-6		Maximum drawbar pull, laden / unladen, 5 minute rating ***		N	16090/16870	16430/17210	19100/19920	25100/25620
5-7	Gradeability, laden / unladen, 30 minute rating **** (11)		%	14/23	13/22	22/25	23/25	
5-8	Maximum gradability, laden / unladen, *** (11)		%	21/25	21/25	25/25	33/25	
	Gradeability, laden / unladen, 60 minute rating		%	10/17	11/18	19/25	19/25	
5-9	Acceleration time, laden/unladen, 15m (10)		s	5.8/5.4	5.7/5.4	5.6/5.2	5.4/4.9	
5-10	Service brake			Wet disc - oil immersed				
ELECTRIC DRIVE	6-1	Drive motor rating S2 60 min		kW	2x 8.8		2x 12	
	6-2	Lift motor rating at S3 15%		kW	20.1		21.5	
ADDITIONAL DATA	6-6	Energy consumption according to DIN EN 16796 (12)		kWh/h	4.8	7	6.3	6.7
	10-1	Operating pressure for attachments		bar	180			
	10-2	Oil volume for attachments (13)		l/min	40			
	10-3	Hydraulic oil tank, capacity		l	21.2			
	10-7	Sound pressure level at the driver's seat (14)		dB (A)	71			
	10-8	Towing coupling, type DIN			Pin			

## GENERAL SPECIFICATIONS

				Yale			
GENERAL	1-1	Manufacturer		ERC3.2VG2			
	1-2	Model designation		Standard			
	1-2-1	Model		Electric (battery)			
	1-3	Drive: electric (battery or mains), diesel, petrol, LPG		Seated			
	1-4	Operator type: hand, pedestrian, standing, seated, order-picker		3200			
	1-5	Rated capacity/rated load	Q	kg	600		
	1-6	Load centre distance	c	mm	435		
	1-8	Load distance, centre of drive axle to fork	x	mm	992		
		Battery Compartment Width		mm	607 / 594		
		Battery Compartment Height		mm	933	1015	
	Nominal Battery Compartment		mm	933	1015		
	Actual Battery Compartment		mm	1478	1560		
1-9	Wheelbase	y	mm	5549			
WEIGHT	2-1	Service weight (1)		kg	5427		
	2-2	Axle loading laden, front/rear (1)		kg	7396 / 1353		
	2-3	Axle loading unladen, front/rear (1)		kg	2173 / 3376		
WHEELS	6-5	Battery weight (min/max)		kg	1410/1860		
	3-1	Tyres, front/rear		Cushion, smooth			
	3-2	Tyre size, front		in	21 x 9 x 15		
	3-3	Tyre size, rear		in	16 x 7 x 10.5		
	3-5	Number of wheels, front/rear (X = driven)			2x / 2		
	3-6	Tread, front *	b10	mm	934		
DIMENSIONS	3-7	Tread, rear	β11	mm	947		
	4-1	Tilt of mast / fork carriage forward / backward	/	(o)	5 / 5		
	4-2	Height, mast lowered	h1	mm	2230		
	4-3	Free lift (2)	h2	mm	100		
	4-4	Lift (2)	h3	mm	3028		
	4-5	Height, mast extended (3)	h4	mm	3280		
	4-7	Height of overhead guard (4)	h6	mm	2248		
	4-8	Seat height relating to SIP/stand height (5)	h7	mm	1254		
	4-12	Coupling height	h10	mm	279		
	4-19	Overall length	l1	mm	3355	3423	
	4-20	Length to face of forks (6)	l2	mm	2288	2356	
	4-21	Overall width *	b1	mm	1068		
	4-22	Fork dimensions DIN ISO 2331	s/e/l	mm	40 x 100 x 1067		
	4-23	Fork carriage ISO 2328, class/type A, B			II A		
	4-24	Fork carriage width (7)	b3	mm	977		
	4-31	Ground clearance, laden, below mast	m1	mm	37		
	4-32	Ground clearance, centre of wheelbase	m2	mm	98		
	4-33	Load dimensions b12 x l6 crossways	b12/l6	mm	1200 x 1000		
	4-34-1	Aisle width for pallets 1000 x 1200 crossways	Ast	mm	3611	3658	
	4-34-2	Aisle width for pallets 800 x 1200 lengthways	Ast	mm	3772	3821	
	4-35	Turning radius	Wa	mm	1927	1977	
	4-36	Internal turning radius	b13	mm	221	233	
	4-41	90° intersecting aisle (with pallet W = 1200mm, L = 1000mm)	W2	mm	1958	1980	
4-42	Step height (from ground to running board) (9)		mm	475	475		
4-43	Step height (between intermediate steps between running board and floor)		mm	289	289		
PERFORMANCE	8-1	Drive control			Intelimatch	Duramatch	
	6-4	Battery voltage/nominal capacity K5		V / Ah	AC induction	Permanent magnet	
	5-1	Travel speed, laden/unladen, Extended shift off (10)		km/h	36	48	48
	5-1-1	Travel speed, laden/unladen, Extended shift on (10)		km/h	16.2/16.4	18.2/17.7	19.9/19.5
	5-2	Lift speed, laden/unladen, 2-stg LFL		m/s	0.42/0.62	0.43/0.62	0.46/0.64
	5-2-1	Lift speed, laden/unladen, 2-stg FFL		m/s	0.39/0.58	0.4/0.58	0.43/0.6
	5-2-2	Lift speed, laden/unladen, 3-stg FFL		m/s	0.4/0.6	0.41/0.6	0.44/0.62
	5-2-3	Lift speed, laden/unladen, 4-stg FFL		m/s	N/A		
	5-3	Lowering speed, laden/unladen, 2-stg LFL		m/s	0.48/0.52		
	5-3-1	Lowering speed, laden/unladen, 2-stg FFL		m/s	0.45/0.49		
	5-3-2	Lowering speed, laden/unladen, 3-stg FFL		m/s	0.46/0.5		
	5-3-3	Lowering speed, laden/unladen, 4-stg FFL		m/s	N/A		
	5-5	Drawbar pull, laden / unladen, 60 minute rating **		N	7850/8550	8400/9110	14920/15720
	5-6	Maximum drawbar pull, laden / unladen, 5 minute rating ***		N	16030/16850	16360/17190	19040/19900
	5-7	Gradeability, laden / unladen, 30 minute rating **** (11)		%	13/23	12/22	21/26
5-8	Maximum gradability, laden / unladen, *** (11)		%	20/26	20/26	23/26	
5-9	Acceleration time, laden/unladen, 15m (10)		s	9/17	10/18	18/26	
5-10	Service brake			5.9/5.5	5.8/5.4	5.7/5.2	
ELECTRIC DRIVE	6-1	Drive motor rating S2 60 min		kW	Wet disc - oil immersed		
	6-2	Lift motor rating at S3 15%		kW	2x 8.8	2x 12	
ADDITIONAL DATA	6-6	Energy consumption according to DIN EN 16796 (12)		kWh/h	20.1	21.5	
	10-1	Operating pressure for attachments		bar	4.9		
	10-2	Oil volume for attachments (13)		l/min	7.1	6.6	
	10-3	Hydraulic oil tank, capacity		l	6.9		
	10-7	Sound pressure level at the driver's seat (14)		dB (A)	71		
10-8	Towing coupling, type DIN			Pin			

## GENERAL SPECIFICATIONS

GENERAL	1-1	Manufacturer			Yale		
	1-2	Model designation			ERC3.5VG2		
	1-2-1	Model			Standard		
	1-3	Drive: electric (battery or mains), diesel, petrol, LPG			Electric (battery)		
	1-4	Operator type: hand, pedestrian, standing, seated, order-picker			Seated		
	1-5	Rated capacity/rated load	Q	kg	3500		
	1-6	Load centre distance	c	mm	600		
	1-8	Load distance, centre of drive axle to fork	x	mm	435		
		Battery Compartment Width		mm	992		
		Battery Compartment Height		mm	607 / 594		
	Nominal Battery Compartment		mm	1015			
	Actual Battery Compartment		mm	1015			
	1-9	Wheelbase	y	mm	1560		
WEIGHT	2-1	Service weight (1)		kg	5702		
	2-2	Axle loading laden, front/rear (1)		kg	7857 / 1344		
	2-3	Axle loading unladen, front/rear (1)		kg	2261 / 3441		
WHEELS	6-5	Battery weight (min/max)		kg	1550/2000		
	3-1	Tyres, front/rear			Cushion, smooth		
	3-2	Tyre size, front		in	21 x 9 x 15		
	3-3	Tyre size, rear		in	16 x 7 x 10.5		
	3-5	Number of wheels, front/rear (X = driven)			2x / 2		
	3-6	Tread, front *	b10	mm	934		
DIMENSIONS	3-7	Tread, rear	β11	mm	947		
	4-1	Tilt of mast / fork carriage forward / backward	/	(o)	5 / 5		
	4-2	Height, mast lowered	h1	mm	2230		
	4-3	Free lift (2)	h2	mm	100		
	4-4	Lift (2)	h3	mm	3028		
	4-5	Height, mast extended (3)	h4	mm	3280		
	4-7	Height of overhead guard (4)	h6	mm	2248		
	4-8	Seat height relating to SIP/stand height (5)	h7	mm	1254		
	4-12	Coupling height	h10	mm	279		
	4-19	Overall length	l1	mm	3437		
	4-20	Length to face of forks (6)	l2	mm	2370		
	4-21	Overall width *	b1	mm	1068		
	4-22	Fork dimensions DIN ISO 2331	s/e/l	mm	40 x 100 x 1067		
	4-23	Fork carriage ISO 2328, class/type A, B			II A		
	4-24	Fork carriage width (7)	b3	mm	977		
	4-31	Ground clearance, laden, below mast	m1	mm	37		
	4-32	Ground clearance, centre of wheelbase	m2	mm	98		
	4-33	Load dimensions b12 x l6 crossways	b12/l6	mm	1200 x 1000		
	4-34-1	Aisle width for pallets 1000 x 1200 crossways	Ast	mm	3689		
	4-34-2	Aisle width for pallets 800 x 1200 lengthways	Ast	mm	3852		
	4-35	Turning radius	Wa	mm	2008		
	4-36	Internal turning radius	b13	mm	233		
	4-41	90° intersecting aisle (with pallet W = 1200mm, L = 1000mm)	W2	mm	1994		
	4-42	Step height (from ground to running board) (9)		mm	475		
	4-43	Step height (between intermediate steps between running board and floor)		mm	289		
	PERFORMANCE	8-1	Drive control			Intelimatch	
		6-4	Battery voltage/nomical capacity K5	V / Ah		AC induction	
5-1		Travel speed, laden/unladen, Extended shift off (10)	km/h		Permanent magnet		
5-1-1		Travel speed, laden/unladen, Extended shift on (10)	km/h		36	48	48
5-2		Lift speed, laden/unladen, 2-stg LFL	m/s		48	80	
5-2-1		Lift speed, laden/unladen, 2-stg FFL	m/s		16.0/16.2	17.9/17.7	19.9/19.5
5-2-2		Lift speed, laden/unladen, 3-stg FFL	m/s		15.3/16.1	17.7/17.7	19.9/19.5
5-2-3		Lift speed, laden/unladen, 4-stg FFL	m/s		0.4/0.62	0.41/0.62	0.44/0.64
5-3		Lowering speed, laden/unladen, 2-stg LFL	m/s		0.38/0.58	0.38/0.58	0.41/0.6
5-3-1		Lowering speed, laden/unladen, 2-stg FFL	m/s		0.39/0.6	0.39/0.6	0.42/0.62
5-3-2		Lowering speed, laden/unladen, 3-stg FFL	m/s		N/A		
5-3-3		Lowering speed, laden/unladen, 4-stg FFL	m/s		0.48/0.52		
5-5		Drawbar pull, laden / unladen, 60 minute rating **	N		0.45/0.49		
5-6		Maximum drawbar pull, laden / unladen, 5 minute rating ***	N		0.46/0.5		
5-7		Gradeability, laden / unladen, 30 minute rating **** (11)	%		N/A		
5-8		Maximum gradability, laden / unladen, *** (11)	%		7770/8510	8320/9070	14840/15680
		Gradeability, laden / unladen, 60 minute rating	%		15950/16810	16280/17150	18960/19860
5-9	Acceleration time, laden/unladen, 15m (10)	s		12/22	12/21	20/24	
5-10	Service brake			18/24	19/24	22/24	
ELECTRIC DRIVE	6-1	Drive motor rating S2 60 min	kW		9/16	9/17	17/24
	6-2	Lift motor rating at S3 15%	kW		5.9/5.5	5.8/5.4	5.8/5.2
ADDITIONAL DATA	6-6	Energy consumption according to DIN EN 16796 (12)	kWh/h		5.6/5.1		
	10-1	Operating pressure for attachments	bar		Wet disc - oil immersed		
	10-2	Oil volume for attachments (13)	l/min		2x 8.8		
	10-3	Hydraulic oil tank, capacity	l		2x 12		
	10-7	Sound pressure level at the driver's seat (14)	dB (A)		20.1		
	10-8	Towing coupling, type DIN			7.6		

**MAST TABLE**

Cushion, smooth tires							Battery compartment													
Maximum Fork Lift (mm)	Lowered Height (mm)	Extended Height without LBR (mm)	Extended Height with 1220 LBR (mm)	Free Lift Height bottom of forks (mm)	Free Lift Height Top of Forks (mm)	Back tilt (°)	700	700	786	786	847	847	700	700	786	786	847	847	847	847
							ERC2.2VG2	ERC2.2VG2	ERC2.2VG2	ERC2.5VG2	ERC2.2VG2	ERC2.2VG2	ERC2.5VG2	ERC2.5VG2	ERC2.5VG2	ERC2.5VG2	ERC2.5VG2	ERC2.5VG2	ERC2.5VG2	ERC2.5VG2
							Capacities (kg) @ 600mm Load Center	Capacities (kg) @ 500mm Load Center	Capacities (kg) @ 600mm Load Center	Capacities (kg) @ 500mm Load Center	Capacities (kg) @ 600mm Load Center	Capacities (kg) @ 500mm Load Center	Capacities (kg) @ 600mm Load Center	Capacities (kg) @ 500mm Load Center	Capacities (kg) @ 600mm Load Center	Capacities (kg) @ 500mm Load Center	Capacities (kg) @ 600mm Load Center	Capacities (kg) @ 500mm Load Center	Capacities (kg) @ 600mm Load Center	Capacities (kg) @ 500mm Load Center
<b>2-STAGE LIMITED FREE LIFT</b>																				
3260	2132	3827	4480	100	140	5	2080	2200	2090	2200	2060	2200	2370	2500	2370	2500	2370	2500	2540	2700
3360	2182	3927	4580	100	140	5	2070	2200	2090	2200	2060	2200	2370	2500	2370	2500	2370	2500	2540	2700
3460	2232	4027	4680	100	140	5	2070	2200	2090	2200	2060	2200	2370	2500	2370	2500	2370	2500	2540	2700
3660	2332	4227	4880	100	140	5	2070	2200	2090	2200	2050	2200	2370	2500	2370	2500	2370	2500	2540	2700
3760	2382	4327	4980	100	140	5	2070	2200	2080	2200	2050	2200	2360	2500	2360	2500	2360	2500	2540	2700
3900	2532	4467	5120	100	140	5	2070	2200	2080	2200	2050	2200	2360	2500	2360	2500	2360	2500	2540	2700
4200	2682	4767	5420	100	140	5	2060	2200	2070	2200	2040	2200	2350	2500	2350	2500	2350	2500	2530	2700
4500	2832	5067	5720	100	140	5	2030	2180	2050	2180	2020	2180	2330	2480	2330	2480	2330	2480	2520	2680
4800	2982	5367	6020	100	140	5	1990	2140	2000	2140	1980	2140	2280	2440	2280	2430	2280	2430	2460	2630
5000	3182	5567	6220	100	140	5	1950	2110	1970	2110	1940	2110	2240	2400	2240	2400	2240	2400	2420	2600
5500	3432	6067	6720	100	140	5	1870	2040	1880	2030	1860	2040	2150	2210	2150	2260	2150	2250	2330	2480
6100	3832	6667	7320	100	140	5	1730	1730	1770	1840	1760	1900	1840	1840	1890	1890	1890	1890	1940	1940
<b>2-STAGE FULL FREE LIFT</b>																				
2990	1982	3551	4210	722	762	5	2080	2200	2100	2200	2100	2200	2390	2500	2380	2500	2380	2500	2540	2700
3240	2082	3801	4460	822	862	5	2070	2200	2090	2200	2090	2200	2390	2500	2370	2500	2370	2500	2540	2700
3340	2132	3901	4560	872	912	5	2070	2200	2090	2200	2090	2200	2390	2500	2370	2500	2370	2500	2540	2700
3440	2182	4001	4660	922	962	5	2070	2200	2090	2200	2090	2200	2390	2500	2370	2500	2370	2500	2540	2700
3540	2232	4101	4760	972	1012	5	2070	2200	2090	2200	2090	2200	2380	2500	2370	2500	2370	2500	2540	2700
3640	2282	4201	4860	1022	1062	5	2070	2200	2080	2200	2080	2200	2380	2500	2360	2500	2360	2500	2540	2700
3740	2332	4301	4960	1072	1112	5	2060	2200	2080	2200	2080	2200	2380	2500	2360	2500	2360	2500	2540	2700
3840	2382	4401	5060	1122	1162	5	2060	2200	2080	2200	2080	2200	2380	2500	2360	2500	2360	2500	2540	2700
4060	2532	4621	5280	1272	1312	5	2060	2200	2070	2200	2070	2200	2370	2500	2350	2500	2350	2500	2540	2700
4560	2782	5121	5780	1522	1562	5	2020	2170	2030	2170	2040	2170	2320	2470	2310	2470	2310	2470	2500	2670
4960	2982	5521	6180	1722	1762	5	1960	2110	1970	2110	1980	2120	2250	2410	2250	2400	2250	2400	2430	2600
5560	3332	6121	6780	2072	2112	5	1860	2020	1870	2020	1880	2030	2150	2200	2130	2250	2130	2240	2310	2500
<b>3-STAGE FULL FREE LIFT</b>																				
4400	1982	4952	5620	722	762	5	2060	2200	2070	2200	2070	2200	2340	2500	2360	2500	2350	2500	2540	2700
4650	2032	5202	5870	772	812	5	2020	2160	2040	2160	2040	2160	2300	2460	2320	2460	2310	2460	2500	2660
4800	2082	5352	6020	822	862	5	2000	2140	2020	2140	2020	2140	2290	2440	2290	2430	2280	2430	2480	2630
4950	2132	5502	6170	872	912	5	1980	2120	1990	2120	2000	2120	2260	2410	2270	2410	2260	2410	2450	2610
5100	2232	5652	6320	972	1012	5	1950	2100	1970	2100	1970	2100	2240	2390	2240	2390	2240	2390	2420	2580
5250	2282	5802	6470	1022	1062	5	1930	2070	1940	2070	1950	2080	2210	2210	2210	2330	2210	2320	2400	2560
5550	2382	6102	6770	1122	1162	5	1880	1970	1890	2020	1900	2030	2090	2090	2140	2140	2130	2130	2340	2500
5700	2482	6252	6920	1222	1262	5	1850	1880	1860	1980	1870	2010	2000	2040	2040	2040	2040	2040	2310	2470
6150	2632	6702	7370	1372	1412	5	1630	1630	1750	1750	1790	1800	1720	1720	1780	1780	1780	1780	2190	2190
6450	2782	7002	7670	1522	1562	5	1480	1480	1590	1590	1660	1660	1550	1550	1610	1610	1620	1620	1940	1940
6900	2982	7452	8120	1722	1762	5	1250	1250	1380	1380	1450	1450	1290	1290	1370	1370	1390	1390	1610	1610
7500	3232	8052	8720	1972	2012	5	960	960	1110	1110	1190	1190	980	980	1070	1070	1110	1110	1220	1220
8100	3482	8652	9320	2222	2262	5	720	720	880	880	930	930	720	720	820	820	870	870	930	930
<b>4-STAGE FULL FREE LIFT</b>																				
4940	1982	5492	6170	712	752	4	1860	2060	1860	2060	1860	2060	2050	2220	2050	2230	2050	2220	2050	2270
5240	1982	5792	6470	712	752	4	1860	1930	1860	2000	1860	2030	2040	2040	2050	2060	2030	2050	2050	2270
5540	1982	6092	6770	712	752	4	1780	1780	1840	1850	1860	1890	1880	1880	1890	1900	1880	1890	2050	2270
5790	2032	6346	7024	762	802	4	1650	1650	1730	1730	1770	1770	1740	1740	1770	1770	1760	1770	2050	2250
6100	2132	6650	7328	862	902	4	1520	1520	1600	1600	1640	1640	1590	1590	1630	1630	1630	1630	2040	2090
6400	2232	6954	7632	962	1002	4	1390	1390	1470	1470	1520	1520	1450	1450	1500	1500	1500	1500	1890	1950
6710	2332	7261	7939	1062	1102	4	1260	1260	1360	1360	1410	1410	1310	1310	1370	1370	1370	1370	1720	1790
7010	2432	7562	8240	1162	1202	4	1140	1140	1250	1250	1300	1300	1180	1180	1240	1240	1250	1250	1550	1660
7310	2532	7866	8544	1262	1302	4	1030	1030	1130	1130	1200	1200	1060	1060	1120	1120	1130	1130	1380	1520
7620	2632	8170	8848	1362	1402	4	910	910	1010	1020	1050	1090	940	940	1010	1010	1020	1020	1190	1320
7920	2732	8474	9152	1462	1502	4	800	800	820	910	870	960	810	810	890	890	910	910	1010	1120
8230	2832	8778	9456	1562	1602	4	660	700	630	700	690	760	700	700	750	780	750	810	810	900
8530	2932	9082	9760	1662	1702	4	460	510	430	480	500	560	580	600	600	650	600	600	620	680
8830	3032	9386	10064	1762	1802	4	270	290	230	260	310	340	370	410	330	370	330	360	410	460
9140	3132	9690	10368	1862	1902	4	60	70	20	30	110	120	150	170	110	120	100	120	200	220

**MAST TABLE**

Cushion, smooth tires							Battery compartment							
Maximum Fork Lift (mm)	Lowered Height (mm)	Extended Height without LBR (mm)	Extended Height with 1220 LBR (mm)	Free Lift Height bottom of forks (mm)	Free Lift Height Top of Forks (mm)	Back tilt (°)	847	847	933	933	1015	1015	1015	1015
							ERC3.0VG2	ERC3.2VG2	ERC3.2VG2	ERC3.5VG2	ERC3.0VG2	ERC3.2VG2	ERC3.2VG2	ERC3.5VG2
							Capacities (kg) @ 600mm Load Center	Capacities (kg) @ 500mm Load Center	Capacities (kg) @ 600mm Load Center	Capacities (kg) @ 500mm Load Center	Capacities (kg) @ 600mm Load Center	Capacities (kg) @ 500mm Load Center	Capacities (kg) @ 600mm Load Center	Capacities (kg) @ 500mm Load Center
<b>2-STAGE LIMITED FREE LIFT</b>														
2880	2032	3518	4098	100	150	5	2820	3000	2970	3200	3030	3200	3310	3500
2980	2082	3618	4198	100	150	5	2820	3000	2970	3200	3030	3200	3310	3500
3080	2132	3718	4298	100	150	5	2820	3000	2970	3200	3030	3200	3310	3500
3180	2182	3818	4398	100	150	5	2820	3000	2970	3200	3030	3200	3310	3500
3280	2232	3918	4498	100	150	5	2820	3000	2960	3200	3030	3200	3310	3500
3380	2282	4018	4598	100	150	5	2810	3000	2960	3200	3020	3200	3310	3500
3480	2332	4118	4698	100	150	5	2810	3000	2960	3200	3020	3200	3300	3500
3580	2382	4218	4798	100	150	5	2810	3000	2960	3200	3020	3200	3300	3500
3680	2532	4318	4898	100	150	5	2800	3000	2950	3200	3010	3200	3300	3500
3880	2632	4518	5098	100	150	5	2800	3000	2940	3200	3010	3200	3290	3500
4180	2782	4818	5398	100	150	5	2790	3000	2940	3200	3000	3200	3280	3500
4480	2932	5118	5698	100	150	5	2760	2960	2900	3160	2960	3160	3240	3460
4780	3182	5418	5998	100	150	5	2700	2920	2840	3110	2900	3110	3180	3240
5480	3532	6118	6698	100	150	5	2410	2410	2410	2410	2410	2410	2410	2410
5880	3832	6518	7098	100	150	5	2020	2020	2020	2020	2020	2020	2020	2020
<b>2-STAGE FULL FREE LIFT</b>														
3000	2032	3632	4224	1067	1117	5	2830	3000	2980	3200	3040	3200	3320	3500
3100	2082	3732	4324	1117	1167	5	2830	3000	2970	3200	3040	3200	3320	3500
3200	2132	3832	4424	1167	1217	5	2820	3000	2970	3200	3030	3200	3310	3500
3300	2182	3932	4524	1217	1267	5	2820	3000	2970	3200	3030	3200	3310	3500
3400	2232	4032	4624	1267	1317	5	2820	3000	2970	3200	3030	3200	3310	3500
3500	2282	4132	4724	1317	1367	5	2820	3000	2960	3200	3030	3200	3310	3500
3600	2332	4232	4824	1367	1417	5	2820	3000	2960	3200	3020	3200	3310	3500
3700	2382	4332	4924	1417	1467	5	2810	3000	2960	3200	3020	3200	3300	3500
4000	2582	4632	5224	1617	1667	5	2800	3000	2950	3200	3010	3200	3300	3500
4500	2832	5132	5724	1867	1917	5	2760	2960	2910	3160	2970	3160	3250	3460
5000	3132	5632	6224	2167	2217	5	2670	2880	2820	3080	2870	3070	3150	3260
5400	3332	6032	6624	2367	2417	5	2590	2770	2740	2770	2770	2770	2770	2770
<b>3-STAGE FULL FREE LIFT</b>														
4320	2032	4934	5538	762	812	5	2780	2970	2930	3170	2990	3170	3270	3470
4470	2082	5084	5688	812	862	5	2760	2950	2900	3150	2960	3150	3240	3450
4620	2132	5234	5838	862	912	5	2730	2930	2880	3120	2940	3120	3220	3420
4770	2232	5384	5988	962	1012	5	2700	2900	2850	3100	2910	3100	3190	3390
4920	2282	5534	6138	1012	1062	5	2670	2870	2820	3070	2880	3070	3160	3370
5070	2332	5684	6288	1062	1112	5	2650	2850	2790	3040	2850	3040	3130	3340
5220	2382	5834	6438	1112	1162	5	2620	2820	2760	3020	2820	3010	3100	3310
5370	2482	5984	6588	1212	1262	5	2590	2780	2730	2990	2790	2980	3060	3280
5520	2532	6134	6738	1262	1312	5	2560	2650	2700	2950	2750	2950	3030	3140
5820	2632	6434	7038	1362	1412	5	2400	2400	2640	2700	2690	2780	2870	2870
6120	2782	6734	7338	1512	1562	5	2170	2170	2450	2450	2540	2540	2610	2610
6570	2982	7184	7788	1712	1762	5	1830	1830	2110	2110	2210	2210	2250	2250
7020	3132	7634	8238	1862	1912	5	1510	1510	1790	1790	1900	1900	1930	1930
<b>4-STAGE FULL FREE LIFT</b>														
4840	1982	5456	6060	712	762	4	2000	2170	2140	2200	2170	2200	2170	2200
5020	1982	5636	6240	712	762	4	1920	2070	2060	2200	2090	2200	2120	2200
5200	1982	5816	6420	712	762	4	1840	1980	1980	2140	2010	2180	2040	2200
5430	2032	6046	6650	762	812	4	1750	1880	1890	2040	1930	2080	1950	2110
5710	2132	6326	6930	862	912	4	1650	1760	1790	1920	1830	1970	1850	1990
5990	2232	6606	7210	962	1012	4	1540	1640	1680	1800	1720	1850	1740	1870
6270	2332	6886	7490	1062	1112	4	1440	1530	1580	1690	1630	1750	1640	1760
6550	2432	7166	7770	1162	1212	4	1350	1420	1490	1590	1540	1650	1550	1660
6830	2532	7446	8050	1262	1312	4	1250	1320	1400	1480	1460	1550	1450	1550
7110	2632	7726	8330	1362	1412	4	1160	1210	1300	1370	1360	1440	1360	1450
7390	2732	8006	8610	1462	1512	4	1060	1110	1210	1280	1270	1350	1270	1350
7670	2832	8286	8890	1562	1612	4	970	1010	1130	1190	1190	1260	1190	1250
7950	2932	8566	9170	1662	1712	4	880	910	1040	1090	1120	1160	1110	1160
8230	3032	8846	9450	1762	1812	4	800	810	970	1000	1040	1080	1030	1070
8230	3032	8846	9450	1762	1812	4	800	810	970	1000	1040	1080	1030	1070

**BATTERY AND COMPARTMENT SPECIFICATIONS**

Battery compartment	Width	Length	Height	"X"	"Y"	"Z"	Volts	Weight	
	mm							kg	
700	992	700	607	983	691	597	36	1050	1500
							48		
							80		
786	992	786	607	983	777	597	36	1150	1600
							48		
							80		
847	992	847	607	983	838	597	36	1320	1770
							48		
							80		
933	992	933	607	983	924	597	36	1410	1860
							48		
							80		
1015	992	1015	607	983	1006	597	36	1550	2000
							48		
							80		

X = Battery Width, Y = Battery Length, Z = Battery Height

## FEATURES LIST

CONSTRUCTION	STD	OPT	LIFT OPTIONS - HYDRAULICS	STD	OPT
Intelmatch 36V electrical system	●		Mechanical Levers	●	
Intelmatch 48V electrical system		●	E-Hydraulic Mini Levers		●
Duramatch 48V electrical system	●		E-Hydraulic Dual Joystick Levers		●
Duramatch 80V electrical system		●	3-Function (1 AUX) Hydraulic Valve	●	
Key Switch Start	●		4-Function (2 AUX) Hydraulic Valve		●
Keyless Start With Operator Password		●	Clamping Function		●
Keyless Start With Extra Key Under Hood		●	3-Function (1 AUX) Hose Group		●
Standard Construction - Operating Temps (0° C to 49°C)	●		4-Function (2 AUX) Hose Group		●
Cooler/Freezer Package (-29° C to 49°C)		●	Without Hose Group	●	
Battery Compartment Sizes:	-	-	Hydraulic System Monitoring	●	
• 2200, 2500kg - 700mm Length	●		<b>CHASSIS - DRIVE &amp; STEER TIRES</b>	<b>STD</b>	<b>OPT</b>
• 2200, 2500, 2700kg - 762mm Length		●	Standard Tread	●	
• 2200, 2500kg - 847mm Length		●	Wide Tread		●
• 3000 kg - 847mm Length	●		Narrow Tread		●
• 3200kg - 933mm Length	●		Cushion, Smooth Drive Tires	●	
• 3200kg - 1015mm Length		●	Non-Marking Cushion, Smooth Drive Tires		●
• 3500kg - 1015mm Length	●		Cushion, Lug Drive Tires		●
UL Class Type E		●	Non-Marking Cushion, Lug Drive Tires		●
UL Class Type EE		●	Cushion, Smooth Steer Tires	●	
Vertical Lift-Out Battery Removal	●		Non-Marking Cushion, Smooth Steer Tires		●
Side Battery Removal Without Rollers		●	Cushion, Lug Steer Tires		●
Battery Spacer		●	Non-Marking Cushion, Lug Steer Tires		●
Conventional Battery Charging System	●		<b>CHASSIS - OPERATOR COMPARTMENT</b>	<b>STD</b>	<b>OPT</b>
Rapid Battery Charging System		●	2248mm Grid Style Overhead Guard	●	
Lead-Acid Battery Configuration	●		2197mm Overhead Guard		●
Lithium-Ion Battery Configuration		●	2137mm Flat Plate Overhead Guard		●
<b>LIFT OPTIONS - FRONT END EQUIPMENT</b>	<b>STD</b>	<b>OPT</b>	Drive-In Rack Overhead Guard		●
2-Stage Limited Free Lift Mast	●		127mm Full Color Touch-Screen Display	●	
2-Stage Full Free Lift Mast		●	Foot Directional Control	●	
3-Stage Full Free Lift Mast		●	Seat-Side Directional Control Switch		●
4-Stage Full Free Lift Mast		●	Auto-Park Brake	●	
Without Mast		●	Steering Wheel With Spinner Knob	●	
5-Degree Forward/5-Degree Back Mast Tilt	●		Steering Wheel Without Spinner Knob		●
10-Degree Forward/5-Degree Back Mast Tilt		●	Infinitely Adjustable Tilt Steer Column	●	
5-Degree Forward/4-Degree Back Mast Tilt		●	Telescoping Steer Column With Tilt Memory		●
Hydraulic Accumulator		●	On-Demand Steering	●	
980mm Hook Type Carriage	●		Full Suspension Vinyl Seat	●	
1070mm Hook Type Carriage		●	Non-Suspension Vinyl Seat		●
980mm Integral Side Shifting Carriage		●	Non-Suspension Cloth Seat		●
980mm Hook Type Attachment Carriage		●	Premium Full Suspension Vinyl Seat		●
980mm Hook Type Side Shifting With Fork Positioner		●	Premium Full Suspension Cloth Seat		●
1070mm Hook Type Attachment Carriage		●	Air-Ride Full Suspension Vinyl Seat		●
Turret Head Attachment Carriage		●	Air-Ride Full Suspension Cloth Seat		●
Hook Type Standard Taper Forks	●		Black Seatbelt	●	
Hook Type Polished & Full Bottom Taper Forks		●	Hi-Vis Red Seatbelt		●
1219mm Load Backrest	●		Hi-Vis Red Seatbelt With Interlock		●
Without Load Backrest		●	Hi-Vis Red With Sequential Interlock		●
			Traction Speed Limiter - Pre-Set to 13km/h or 13/8km/h		●
			Dynamic Stability System	●	

## FEATURES LIST

CHASSIS - OPERATOR COMPARTMENT	STD	OPT
Dual Side-View Mirrors		●
Panoramic Mirror		●
LED Dome Style Reading Light		●
Rear Drive Handle With Horn Button		●
12V Outlet		●
Fire Extinguisher		●
Load Weight Display		●
Operator Pre-Shift Checklist		●
Programmable Maintenance Reminder		●
Operator Password		●
LIGHTS & ALARMS	STD	OPT
Primary DC/DC Converter - Power For Truck Accessories	●	
Auxiliary DC/DC Converter - Power For Customer Installed Accessories		●
Without Lights	●	
LED Work Lights - Key Switch Or Automatic Activation		●
One Rear Work Light - Key Switch Or Automatic Activation		●
Two Front Work Lights - Key Switch Or Automatic Activation		●
Two Front / One Rear Work Lights - Key Switch Or Automatic Activation		●
Less Rear Lights	●	
Blue Or Red Front Spotlight - Continuous Or Directional		●
Blue Or Red Rear Spotlight - Continuous Or Directional		●
Amber Strobe Light		●
Audible Alarm - Reverse		●
Audible Alarm - Forward Or Reverse		●
TECHNOLOGY SOLUTIONS	STD	OPT
Yale Reliant™		●
Yale Vision™ - standard	●	
Yale Vision™ - advanced		●
Pedestrian awareness camera		●

## NOTES

- (1) Max. battery
- (2) Bottom of forks
- (3) Add 641 mm with class II load backrest. Add 568 mm with class III load backrest.
- (4) h6 subject to +/- 5 mm tolerance.
- (5) Full suspension in compressed position specified. Add 40 mm for nominal position.
- (6) With sideshift carriage add 25 mm for Class 2 carriage, 28 mm for Class 3 carriage
- (7) Add 39 mm with load backrest.
- (8) Stacking aisle width (lines 4.34.1 & 4.34.2) is based on the calculation as shown on illustration. Recommended addition of 200 mm to the total clearance (dimension a) for extra operating margin at the rear of the truck.
- (9) HiP Performance settings
- (10) Gradeability figures (lines 5.7 & 5.8) are provided for comparison of tractive performance, but are not intended to endorse the operation of the vehicle on the stated inclines. Follow instructions in the operating manual regarding operation on inclines.
- (11) eLo Performance settings
- (12) Maximum flow set through dash display.
- (13) LPAZ, measured according to the test cycles and based on the weighting values contained in EN12053.

\* Standard / Wide tread

\*\* 60 minute rating

\*\*\* 5 minute rating

\*\*\*\* 30 minute rating

Spec sheet truck based on:- 3260mm (ERC2.2-2.5VG2) / 3078mm (ERC3.0-3.5VG2) TOF 2 stage LFL Mast with standard carriage, 1000 mm forks.

CERTIFICATION: Yale lift trucks meet the design and construction requirements of B56.1-1969, per OSHA Section 1910.178(a)(2), and also comply with the B56.1 revision in effect at time of manufacture. Certification of compliance with the applicable ANSI standards appears on the lift truck. Performance specifications are for a truck equipped as described under Standard Equipment on this technical guide. Performance specifications are affected by the condition of the vehicle and how it is equipped, as well as by the nature, condition of the operating area, proper service and maintenance of the vehicle. If these specifications are critical, the proposed application should be discussed with your dealer.



## About Yale

Yale Lift Truck Technologies leverages over a century of material handling experience and substantial investment in innovation to bring the most advanced technology-driven lift truck solutions to market. The company offers a full line of award-winning lift trucks, including reach trucks, order pickers, turret trucks, pallet jacks and trucks, pallet stackers, tow tractors and counterbalanced forklifts, as well as powerful operator assist solutions, proven automation and a wide range of power sources to help customers adapt to today's demanding supply chain. Yale and its independent dealer network support these solutions with comprehensive after-sales service, parts, financing and training.



**TECNOLOGIAS EM EMPILHADEIRAS**

**Central De Relacionamento • 0800 200-0060 • YALE.COM**

