

GCVX series

4,000kg / 4,500kg / 5,500kg

LP Gas Forklift Trucks



- Designed for high-intensity indoor applications
- Compact design offers excellent manoeuvrability and delivers high productivity
- Intellix Vehicle Management System and CAN bus technology monitor truck systems
- Techtronix 100 transmission delivers precise handling
- AccuTouch minilevers or manual levers

Truck Dimensions

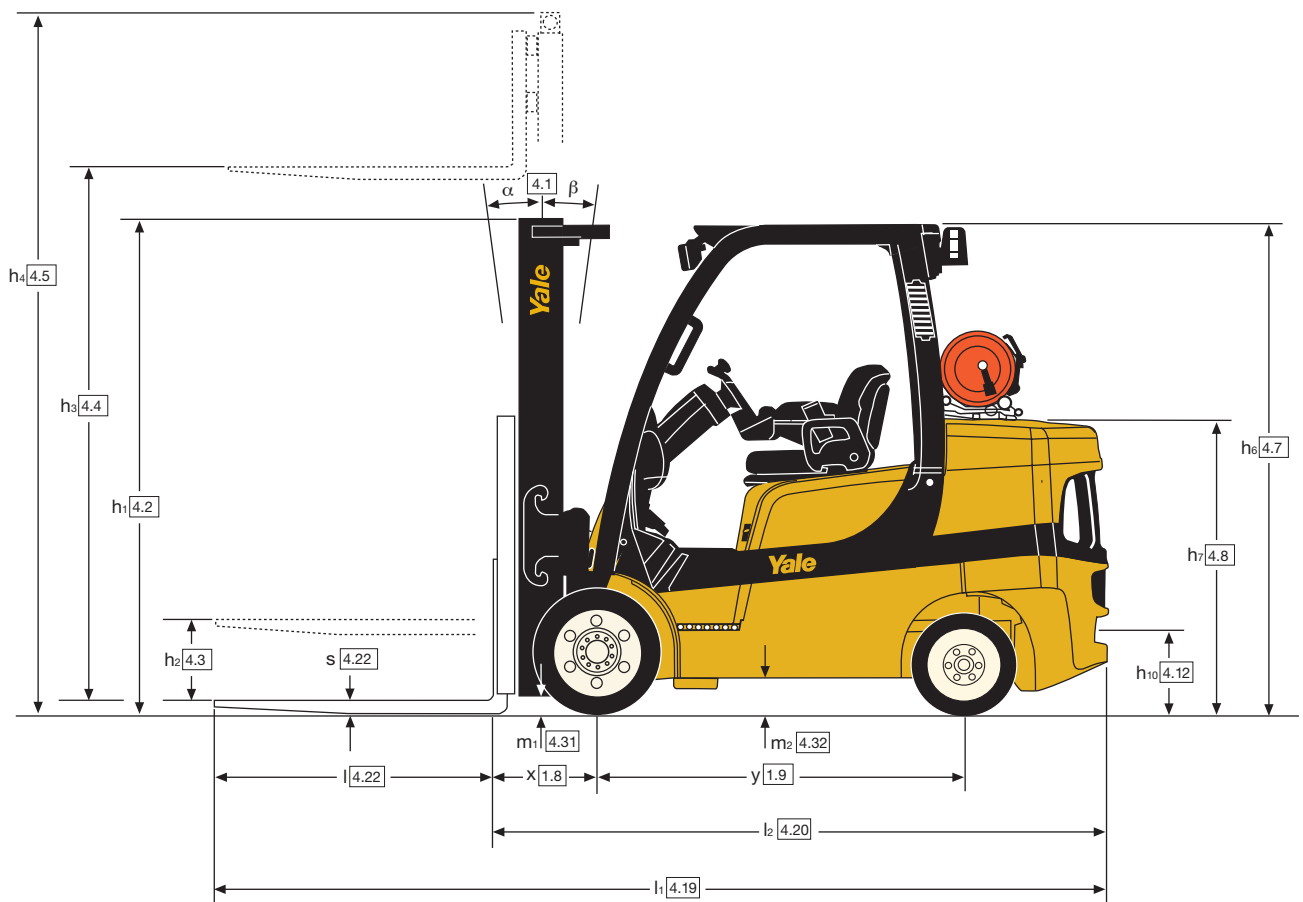
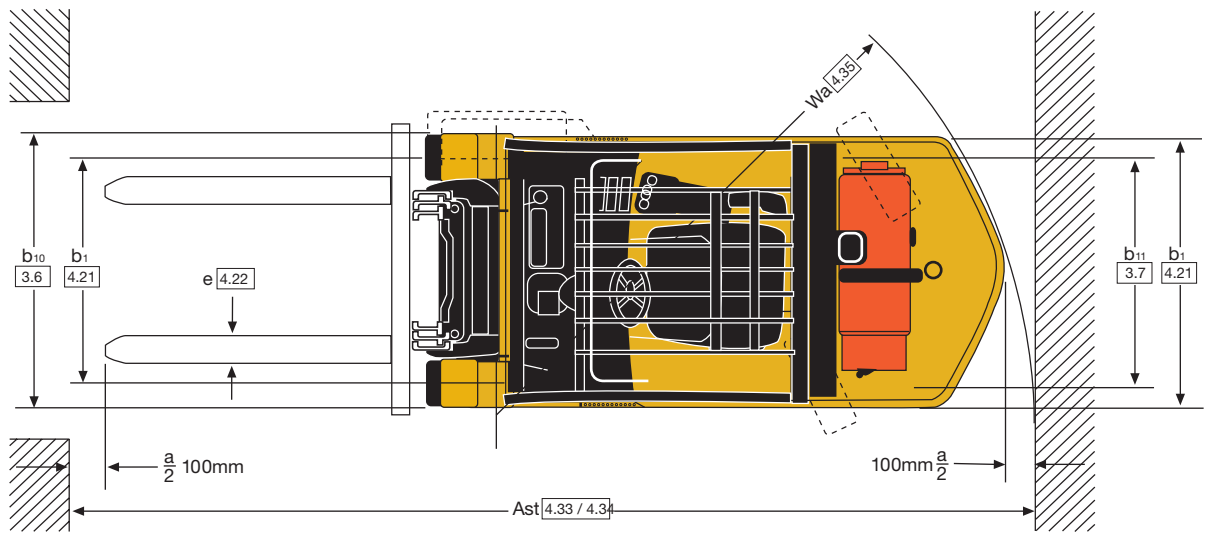

Mast details and capacity ratings (kg) GLC 40VX - Cushion tyres

Model						GLC 40 VX	
Tyre size, front						22 x 9-16	
Overall width, front						1170mm	
Mast	h ₁ (mm)	h _{2+S} (mm)	h _{3+S} (mm)	h ₄ (mm)	Tilt (Back)	Without sideshift	
						Load centre (kg)	
						500	
						Integral sideshift	
						Load centre (kg)	
						500	
2 Stage LFL	2135	150	3050	4225	6	4000	
	2435	150	3650	4285	6	4000	
	2735	150	4250	4885	6	4000	
	2135	1350	3075	5485	6	4000	
2 Stage FFL	2134	1350	4415	4310	6	4000*	
3 Stage FFL	2335	1550	4950	5650	6	3900*	
	2535	1750	5550	6185	6	3760*	
	2735	1950	6000	6785	6	3650*	

* Indicates wide tread is required.

Mast details and capacity ratings (kg) GLC 45VX, GLC 55VX, GLC 55SVX- Cushion tyres

Model						GLC 45 VX		GLC 55 VX		GLC 55S VX	
Tyre size, front						22 x 12-16		22 x 12-16		22 x 12-16	
Overall width, front						1320mm		1320mm		1170mm	
Mast	h ₁ (mm)	h _{2+S} (mm)	h _{3+S} (mm)	h ₄ (mm)	Tilt (Back)	Without sideshift		Without sideshift		Without sideshift	
						Integral sideshift		Integral sideshift		Integral sideshift	
						Load centre (kg)		Load centre (kg)		Load centre (kg)	
						600		600		600	
2 Stage LFL	2140	160	2800	4035	6	4500	4500	5500	5460	5500	5500
	2440	160	3400	4635	6	4500	4500	5500	5450	5500	5500
	2740	160	4000	5235	6	4500	4500	5500	5430	5500	5500
2 Stage FFL	2140	1230	2825	4060	6	4500	4500	5500	5450	5500	5500
3 Stage FFL	2140	1225	4145	5380	6	4500*	4430*	5500*	5260*	5500*	5320*
	2340	1425	4700	5935	6	4500*	4410*	5500*	5250*	5500*	5300*
	2540	1625	5300	6535	6	4380*	4290*	5370*	5100*	5370*	5170*

* Indicates wide tread is required.

Options

- Premium monitoring package
- Powertrain protection system
- High air intake with pre-cleaner
- Radiator screen
- Traction speed limiter
- Load weight indicator
- Hydraulic accumulator
- Return-to-set tilt
- Impact monitor
- Reverse alarm
- Amber strobe light
- Operator password
- Keyless start
- Full-suspension swivel seat
- Foot directional control
- Mirrors
- Light kit
- Swing-out, drop-down EZ-Tank bracket

Engine Specifications

LPG

Engine	Kubota
Cylinders	4
Displacement	3.8 litre
Power	55kW @ 2,400rpm
Torque	300Nm @ 1,000rpm

Masts

A full range of Yale Hi-Vis 2 stage LFL and 2 and 3 stage FFL masts are available.

Yale Hi-Vis masts are designed for maximum visibility, with widely spaced channels, lift chains and main lift cylinders.

VDI 2198 – General Specifications, LP Gas Powered GLC40VX, GLC45VX, GLC55VX, GLC55SVX

Distinguishing mark	1.1	Manufacturer (abbreviation)		Yale	Yale	Yale	Yale	
	1.2	Manufacturer's type designation		GLC 40 VX	GLC 40 VX	GLC 45 VX	GLC 45 VX	
		Engine		Kubota 3.8L,	Kubota 3.8L	Kubota 3.8L	Kubota 3.8L	
		Transmission		Techtronix 100 1-speed	Techtronix 200 (AH) 2-speed	Techtronix 100 1-speed	Techtronix 200 (AH) 2-speed	
		Model		Value	Productivity	Value	Productivity	
		Brake type		Premium Wet Brakes	Premium Wet Brakes	Premium Wet Brakes	Premium Wet Brakes	
	1.3	Drive: electric (battery or mains), diesel, petrol, LPG		LPG	LPG	LPG	LPG	
	1.4	Operator type: hand, pedestrian, standing, seated, order-picker		Seated	Seated	Seated	seated	
	1.5	Rated capacity/rated load	Q (t)	4.0	4.0	4.5	4.5	
Weights	1.6	Load centre distance	c (mm)	500	500	600	600	
	1.8	Load distance, centre of drive axle to fork	x (mm)	447	447	462	462	
	1.9	Wheelbase	y (mm)	1570	1570	1790	1790	
	2.1	Service weight	kg	5795	5795	6977	6977	
	2.2	Axle loading, laden front/rear	kg	8607 / 1188	8607 / 1188	10085 / 1392	10085 / 1392	
	2.3	Axle loading, unladen front/rear	kg	2194 / 3601	2194 / 3601	2916 / 4061	2916 / 4061	
	Tyres/chassis	3.1	Tyres: P=pneumatic, V=cushion, SE=superelastic		V	V	V	V
		3.2	Tyre size, front		22 x 9 x 16	22 x 9 x 16	22 x 12 x 16	22 x 12 x 16
		3.3	Tyre size, rear		18 x 7 x 12.1	18 x 7 x 12.1	18 x 8 x 12.1	18 x 8 x 12.1
3.5		Wheels, number front/rear (x = driven wheels)		2x / 2	2x / 2	2x / 2	2x / 2	
3.6		Tread, front	b10 (mm)	941	941	1015	1015	
3.7		Tread, rear	b11 (mm)	978	978	1004	1004	
Dimensions		4.1	Tilt of mast/fork carriage forward/backward	α / β (°)	5 / 6	5 / 6	5 / 6	5 / 6
	4.2	Height, mast lowered	h1 (mm)	2130	2130	2135	2135	
	4.3	Free lift ⁽¹⁾	h2 (mm)	100	100	100	100	
	4.4	Lift ⁽¹⁾	h3 (mm)	3000	3000	2740	2740	
	4.5	Height, mast extended ⁽²⁾	h4 (mm)	3780	3780	3665	3665	
	4.7	Height of overhead guard (cabin)	h6 (mm)	2171	2171	2175	2175	
	4.8	Seat height/stand height ⁽³⁾	h7 (mm)	1221	1221	1339	1339	
	4.12	Coupling height	h10 (mm)	367	367	371	371	
	4.19	Overall length	l1 (mm)	3630	3630	3969	3969	
	4.20	Length to face of forks	l2 (mm)	2630	2630	2769	2769	
	4.21	Overall width (standard / wide)	b1 / b2 (mm)	1170 / 1270	1170 / 1270	1320 / 1420	1320 / 1420	
	4.22	Fork dimensions ISO 2331	s/e/l (mm)	50 / 125 / 1000	50 / 125 / 1000	60 / 150 / 1200	60 / 150 / 1200	
	4.23	Fork carriage ISO 2328, class/type A, B		IIIA	IIIA	IVA	IVA	
	4.24	Fork carriage width ⁽⁴⁾	b3 (mm)	1070	1070	1070	1070	
	4.31	Ground clearance, laden, below mast	m1 (mm)	114	114	118	118	
	4.32	Ground clearance, centre of wheelbase	m2 (mm)	152	152	156	156	
	4.33	Load dimension b12 / l6 crossways	b12 / l6 (mm)	1200 x 1000	1200 x 1000	1200 x 1000	1200 x 1000	
	4.34	Aisle width predetermined load dimensions ⁽⁵⁾	Ast (mm)	3945	3945	4109	4109	
	4.34.1	Aisle width for pallets 1000 x 1200 crossways ⁽⁵⁾	Ast (mm)	4145	4145	4309	4309	
	4.34.2	Aisle width for pallets 800 x 1200 crossways ⁽⁵⁾	Ast (mm)	4145	4145	4309	4309	
	4.35	Turning radius	Wa (mm)	2298	2298	2447	2447	
4.36	Internal turning radius	b13 (mm)	675	675	762	762		
4.41	90° intersecting aisle (with pallet L = 1000mm x W = 1200mm)	(mm)	2051	2051	2164	2164		
4.42	Step Height (from ground to running board)	(mm)	392	392	396	396		
4.43	Step Height (between intermediate steps and floor)	(mm)	322	322	322	322		
Performance data	5.1	Travel speed, laden/unladen	km/h	18.1 / 18.3	22.1/ 22.5	17.8/ 18.1	21.7 / 22.1	
	5.1.1	Travel speed, laden/unladen, backwards	km/h	18.1 / 18.3	18.1/ 18.3	17.8/ 18.1	17.8/ 18.1	
	5.2	Lift speed, laden/unladen	m/s	0.61 / 0.62	0.61 / 0.62	0.56 / 0.57	0.56 / 0.57	
	5.3	Lowering speed, laden/unladen	m/s	0.55 / 0.47	0.55 / 0.47	0.51 / 0.42	0.51 / 0.42	
	5.5	Drawbar pull, laden/unladen ⁽⁶⁾	N	31725 / 12804	38091/ 12804	34923 / 16916	41944 / 16916	
	5.7	Gradeability, laden/unladen ⁽⁷⁾	%	36.8 / 14.1	45.6 / 14.1	32.6 / 18.7	40.1/ 18.7	
	5.9	Acceleration time, laden/unladen ⁽⁶⁾	s	4.3 / 4.9	4.4 / 5	4.2 / 4.9	4.2 / 5	
	5.10	Service brake		Hydraulic	Hydraulic	Hydraulic	Hydraulic	
	Combustion-engine	7.1	Engine manufacturer/type		Kubota 3.8L LPG	Kubota 3.8L LPG	Kubota 3.8L LPG	Kubota 3.8L LPG
		7.2	Engine power according to ISO 1585	kW	55	55	68	68
7.3		Rated speed	min-1	2400	2400	2400	2400	
7.3.1		Torque at 1/min	Nm/	300 / 1000	300 / 1000	300 / 1000	300 / 1000	
7.4		Number of cylinders/displacement	min-1	4 / 3769	4 / 3769	4 / 3769	4 / 3769	
7.5		Fuel consumption according to VDI cycle	cm ³	4.0	4.0	4.5	4.5	
7.10		Battery voltage/nominal capacity ⁽⁹⁾	l/h or kg/h	12 / 88	12 / 88	12 / 88	12 / 88	
8.1		Type of drive unit	V/Ah	Hydrodynamic	Hydrodynamic	Hydrodynamic	Hydrodynamic	
Addition data		10.1	Operating pressure for attachments	bar	155	155	155	155
		10.2	Oil volume for attachments ⁽¹⁰⁾	l/min	83.3	83.3	83.3	83.3
	10.3	Hydraulic oil tank, capacity	l	76.6	76.6	76.6	76.6	
	10.4	Fuel tank, capacity	l	38.6	38.6	38.6	38.6	
	10.7	Sound pressure level at the driver's seat ⁽¹¹⁾	dB (A)	84	84	84	84	
	10.7.1	Sound power level during the workcycle ⁽¹²⁾	dB (A)	102	102	102	102	
	10.7.2	Guaranteed sound power 2001/ 14 /EC	dB (A)	106	106	106	106	
	10.8	Towing coupling, type DIN		Pin	Pin	Pin	Pin	

⁽¹⁾ Top of forks

⁽²⁾ Add 32mm with load backrest
⁽³⁾ Full suspension seat in depressed position

⁽⁴⁾ W/o load backrest, add 32mm with load backrest
⁽⁵⁾ Stacking aisle width (lines 4.34 & 4.34.1 & 4.34.2) are based on the V.D.I.

standard calculation as shown on illustration. The British Industrial Truck Association recommends the addition of 100 mm to the total clearance (dimension a) for extra operating margin

⁽⁶⁾ at the rear of the truck at 1.6km/h
⁽⁷⁾ at 4.8km/h. Gradeability figures are provided for comparison of tractive

performance, but are not intended to endorse the operation of the vehicle on the stated inclines. Follow instructions in the operating manual regarding operation on inclines.

Yale	Yale	Yale	Yale		Manufacturer (abbreviation)	1.1	Distinguishing mark
GLC 55 VX	GLC 55 VX	GLC 55 SVX	GLC 55 SVX		Manufacturer's type designation	1.2	
Kubota 3.8L	Kubota 3.8L	Kubota 3.8L	Kubota 3.8L		Engine		
Techtronix 100 1-speed	Techtronix 200 2-speed	Techtronix 100 1-speed	Techtronix 200 2-speed		Transmission		
Value	Productivity	Value	Productivity		Model		
Premium Wet Brakes	Premium Wet Brakes	Premium Wet Brakes	Premium Wet Brakes		Brake type		
LPG	LPG	LPG	LPG		Drive: electric (battery or mains), diesel, petrol, LPG	1.3	
seated	seated	seated	seated		Operator type: hand, pedestrian, standing, seated, order-picker	1.4	
5.5	5.5	5.5	5.5	Q (t)	Rated capacity/rated load	1.5	
600	600	600	600	c (mm)	Load centre distance	1.6	
462	462	462	462	x (mm)	Load distance, centre of drive axle to fork	1.8	
1790	1790	1790	1790	y (mm)	Wheelbase	1.9	
7595	7595	7618	7618	kg	Service weight	2.1	
11523 / 1572	11523 / 1572	11729 / 1389	11729 / 1389	kg	Axle loading, laden front/rear	2.2	
2760 / 4835	2760 / 4835	2966 / 4652	2966 / 4652	kg	Axle loading, unladen front/rear	2.3	
V	V	V	V		Tyres: P=pneumatic, V=cushion, SE=superelastic	3.1	
22 x 12 x 16	22 x 12 x 16	22 x 12 x 16	22 x 12 x 16		Tyre size, front	3.2	
18 x 8 x 12.1	18 x 8 x 12.1	18 x 8 x 12.1	18 x 8 x 12.1		Tyre size, rear	3.3	
2x / 2	2x / 2	2x / 2	2x / 2		Wheels, number front/rear (x = driven wheels)	3.5	
1015	1015	1015	1015	b ₁₀ (mm)	Tread, front	3.6	
1004	1004	1004	1004	b ₁₁ (mm)	Tread, rear	3.7	
5 / 6	5 / 6	5 / 6	5 / 6	α / β (°)	Tilt of mast/fork carriage forward/backward	4.1	
2135	2135	2135	2135	h ₁ (mm)	Height, mast lowered	4.2	
100	100	100	100	h ₂ (mm)	Free lift ⁽¹⁾	4.3	
2740	2740	2740	2740	h ₃ (mm)	Lift ⁽¹⁾	4.4	
3665	3665	3665	3665	h ₄ (mm)	Height, mast extended ⁽²⁾	4.5	
2175	2175	2175	2175	h ₆ (mm)	Height of overhead guard (cabin)	4.7	
1339	1339	1339	1339	h ₇ (mm)	Seat height/stand height ⁽³⁾	4.8	
371	371	371	371	h ₁₀ (mm)	Coupling height	4.12	
4061	4061	3899	3899	l ₁ (mm)	Overall length	4.19	
2861	2861	2699	2699	l ₂ (mm)	Length to face of forks	4.20	
1320 / 1420	1320 / 1420	1320 / 1420	1320 / 1420	b ₁ / b ₂ (mm)	Overall width (standard / wide)	4.21	
60 / 150 / 1200	60 / 150 / 1200	60 / 150 / 1200	60 / 150 / 1200	s/e/l (mm)	Fork dimensions ISO 2331	4.22	
IVA	IVA	IVA	IVA		Fork carriage ISO 2328, class/type A, B	4.23	
1070	1070	1070	1070	b ₃ (mm)	Fork carriage width ⁽⁴⁾	4.24	
118	118	118	118	m ₁ (mm)	Ground clearance, laden, below mast	4.31	
156	156	156	156	m ₂ (mm)	Ground clearance, centre of wheelbase	4.32	
1200 x 1000	1200 x 1000	1200 x 1000	1200 x 1000	b ₁₂ / l ₆ (mm)	Load dimension b ₁₂ / l ₆ crossways	4.33	
4196	4196	4037	4037	A _{st} (mm)	Aisle width predetermined load dimensions ⁽⁵⁾	4.34	
4396	4396	4237	4237	A _{st} (mm)	Aisle width for pallets 1000 x 1200 crossways ⁽⁵⁾	4.34.1	
4396	4396	4237	4237	A _{st} (mm)	Aisle width for pallets 800 x 1200 crossways ⁽⁵⁾	4.34.2	
2534	2534	2375	2375	W _a (mm)	Turning radius	4.35	
762	762	762	762	b ₁₃ (mm)	Internal turning radius	4.36	
2211	2211	2161	2161	(mm)	90° intersecting aisle (with pallet L = 1000mm x W = 1200mm)	4.41	
396	396	396	396	(mm)	Step Height (from ground to running board)	4.42	
322	322	322	322	(mm)	Step Height (between intermediate steps and floor)	4.43	
17.7 / 18.1	21.6 / 22.1	17.7 / 18.1	21.6 / 22.1	km/h	Travel speed, laden/unladen	5.1	
17.7 / 18.1	17.7 / 18.1	17.7 / 18.1	17.7 / 18.1	km/h	Travel speed, laden/unladen, backwards	5.1.1	
0.56 / 0.57	0.56 / 0.57	0.56 / 0.57	0.56 / 0.57	m/s	Lift speed, laden/unladen	5.2	
0.51 / 0.42	0.51 / 0.42	0.51 / 0.42	0.51 / 0.42	m/s	Lowering speed, laden/unladen	5.3	
34626 / 15999	41649 / 15999	34626 / 15999	41649 / 15999	N	Drawbar pull, laden/unladen ⁽⁶⁾	5.5	
28.2 / 17.7	34.5 / 17.7	28.2 / 17.7	34.5 / 17.7	%	Gradeability, laden/unladen ⁽⁷⁾	5.7	
4.3 / 5.1	4.3 / 5.2	4.3 / 5.1	4.3 / 5.2	s	Acceleration time, laden/unladen ⁽⁸⁾	5.9	
Hydraulic	Hydraulic	Hydraulic	Hydraulic		Service brake	5.10	
Kubota 3.8L LPG	Kubota 3.8L LPG	Kubota 3.8L LPG	Kubota 3.8L LPG		Engine manufacturer/type	7.1	
68	68	68	68	kW	Engine power according to ISO 1585	7.2	
2400	2400	2400	2400	min-1	Rated speed	7.3	
300 / 1000	300 / 1000	300 / 1000	300 / 1000	Nm/	Torque at 1/min	7.3.1	
4 / 3769	4 / 3769	4 / 3769	4 / 3769	min-1	Number of cylinders/displacement	7.4	
4.9	4.9	4.9	4.9	cm ³	Fuel consumption according to VDI cycle	7.5	
12 / 88	12 / 88	12 / 88	12 / 88	l/h or kg/h	Battery voltage/nominal capacity ⁽⁹⁾	7.10	
Hydrodynamic	Hydrodynamic	Hydrodynamic	Hydrodynamic	V/Ah	Type of drive unit	8.1	
155	155	155	155	bar	Operating pressure for attachments	10.1	
83.3	83.3	83.3	83.3	l/min	Oil volume for attachments ⁽¹⁰⁾	10.2	
76.6	76.6	76.6	76.6	l	Hydraulic oil tank, capacity	10.3	
38.6	38.6	38.6	38.6	l	Fuel tank, capacity	10.4	
84	84	84	84	dB (A)	Sound pressure level at the driver's seat ⁽¹¹⁾	10.7	
102	102	102	102	dB (A)	Sound power level during the workcycle ⁽¹²⁾	10.7.1	
106	106	106	106	dB (A)	Guaranteed sound power 2001/ 14 /EC	10.7.2	
Pin	Pin	Pin	Pin		Towing coupling, type DIN	10.8	

⁽⁸⁾ to 15m (per VDI 2198 December 2012)

⁽¹¹⁾ With and without cab.

Value / Productivity models:
Specification data based on 3050mm (40 / 4.0) / 2800mm (45 / 4.5 - 55 / 5.5) TOF 2 stage LFL mast with standard carriage, 1000mm (40 / 4.0) / 1200mm (45 / 4.5 - 55 / 5.5) forks with e-hydraulics.

All values are nominal values and they are subject to tolerances. For further information, please contact the manufacturer. Yale products might be subject to change

without notice. Lift trucks illustrated may feature optional equipment. Values may vary with alternative configurations.

⁽⁹⁾ Battery ampere hour (Ah) nominal capacity ratings are estimated.

⁽¹²⁾ Lpaz, Measured according to the test cycles and based on the weighting values contained in EN12053.

⁽¹⁰⁾ Variable

GCVX series

Models: GLC 40VX, GLC 45VX, GLC 55VX, GLC 55SVX

Yale Veracitor GC VX Series

This series of trucks is available in two configurations to match your material handling application requirements.

The Value model provides excellent performance for standard and medium-duty applications and is optimized for lowest hourly cost of operation.

The Productivity model delivers maximum performance for medium to heavy-duty applications with state-of-the-art features and industry leading power.

Engines

Yale Veracitor VX Kubota engines feature a rigid cast iron block and main bearing caps. The nodular iron crankshaft is supported on four main bearings and the camshaft is cast iron. Hydraulic valve lifters are used to eliminate the need for manual adjustment. The engine features hardened intake and exhaust valve seats with stellite coated valves for superior durability. All engines are EU emissions compliant and feature closed loop emissions regulation systems that continually monitor exhaust and adjust fuel/air mix as necessary. The engine also features an electronic throttle for precise performance and control.

Fuel System

The Kubota LPG engine uses a sequential port fuel injection system and a vaporizer / regulator to convert the fuel from a liquid to a gas for vapour injection. The Engine Control Unit (ECU) electronically controls the fuel, air, and spark advance to provide the necessary torque. The ECU's inputs include manifold air pressure, manifold air temperature, engine coolant temperature, accelerator pedal position, throttle position, engine speed, cam signal, and oxygen sensor signal.

Transmissions

There are two transmissions configurations available that will handle a wide variety of material handling applications. All transmissions feature electronic inching (which requires no adjustment), electric shift control, neutral start switch, and anti-restart protection. A single pedal controls both inching and braking. A 100 mesh suction and a 10 micron return line filtration protect the transmission from abrasive contaminants.

The Techtronix 100 also features the Auto Deceleration System (ADS), which slows the truck down through the



controlled application of clutch packs, without the need to apply the foot brake. Controlled Power Reversal (CPR) reduces tyre spin by precisely regulating engine speed during full power reversal situations and Controlled Roll-Back (CRB) limits roll-back on gradients to 75mm per second.

Techtronix 200 (AH) includes the Techtronix 100 features, as well as Auto Speed Hydraulics with Automatic Inching Control. This feature automatically increases engine rpm's as hydraulic functions are actuated, while maintaining control over vehicle speed.

The Throttle Response Management feature provides travel speed as a direct result of pedal position, improving truck control. The Techtronix 200 (AH) adds two-speed functionality for extended drawbar pull applications.

Cooling System

The cooling system employs a 48cm blade pusher-type fan. A permanently lubricated water pump and a high capacity, cross-flow radiator ensure rapid heat dissipation. The sealed cooling system operates at 15 psi, the coolant recovery tank allows visual inspection of coolant level. The combi-cooler radiator

features an externally mounted transmission oil cooler for increased heat transfer capability. All radiators are soft mounted for durability.

Drive Axle

The drive axle is designed to withstand heavy-duty loads and absorb shock loads. The wheel hubs rotate on large tapered roller bearings and the drive shaft transmits torsion to the drive axle from the engine and transmission. Transmission torque occurs through an industrial hypoid ring gear and pinion differential assembly. The drive axle is a self-contained assembly that is isolated from the transmission by a heavy-duty rubber isolator. The axle shafts feature a "rolled fillet" root spline design for increased resistance to torsion stress. A magnetic sump plug is used to collect any metal particles that are circulating in the axle oil, preventing component wear.

Brakes

All Yale Veracitor VX models feature oil immersed brakes – Standard Oil immersed brakes for Value models and Premium Oil immersed brakes for Value and Productivity models. The oil immersed disc brakes are internal to the axle for better protection against the elements, debris and contamination.



guard is bar type and offers excellent visibility and reduced noise.

Cowl mounted hydraulic control levers positioned on the right side of the steering column are standard. All trucks are available with a mini-lever armrest, which features a new contoured design, and – in addition to the hydraulic functions - features a horn and direction switch, ensuring

overloads by a main relief valve for the lift circuit and a secondary relief valve for tilt and auxiliary functions. Oil is double filtered through a 100 mesh suction line strainer and 10 micron return line filter. The hydraulic tank is integrated into the frame. For electro-hydraulic controls, an emergency lowering valve is provided to allow the load to be lowered in the event of power loss. O-ring face seal fittings are used in all high pressure hydraulic connections.

Masts

Yale Hi-Vis Masts are available in 2 Stage LFL, 2 Stage FFL and 3 Stage FFL configurations. Masts feature a flush-faced design with geometrically matched, angled load roller bearings which are canted, yet provide full-face roller contact. The mast front rail flange angle coupled with the inverted “J” inner channel and three degree mast rollers significantly reduce channel and roller wear. The “J-hook” mast mounting system allows for convenient mast installation and removal. A non-metallic phenolic mast pivot bushing with woven reinforcement offers high load carrying capability with outstanding durability.

These low pedal effort brakes require no adjustments and very little maintenance, yet provide an extremely long service life.

The new Standard oil-immersed brake axle is a self-contained unit, whereas the Premium oil-immersed brake axle features an additional oil supply routed through the Combi-Cooler. The Premium oil-immersed brake axle is designed for use into multiple shift operations, or where the brakes are in constant use.

Hydraulic Power Steering Hydrostatic steering provides responsive control and eliminates mechanical linkages for reduced surface shock and simplified maintenance. The steering wheel is 30cm in diameter with a textured surface grip and spinner knob, and requires only four turns lock-to-lock. The centre mounted steer cylinder is located within the confines of the steer axle for protection.

Steer Axle

The steer axle is constructed of cast steel and is rubber shock mounted to the frame for reduced wear and vibration. The CSE (Continuous Stability Enhancement) system enhances lateral truck stability through reduced steer axle articulation, while simultaneously allowing uncompromised uneven surface travel.

Operator Compartment The frame has been designed by state-of-the-art finite element methods and contains a rugged, unitized structure with a low step height – this combined with a conveniently placed hand grip provides easy entry and exit to and from the truck.

The ergonomically designed overhead

that all key truck functions are within constant, easy reach.

The Full Suspension Seat, together with the isolated powertrain, provide best in class Whole-Body Vibration levels of 0.6m/s², ensuring that the operator remains comfortable throughout the shift and fatigue, aches and pains are kept to a minimum.

The automotive-style pedal arrangement with a large, single inch/brake pedal is standard. Tilt cylinders are located beneath the floor for uncluttered space and a rubber floor mat reduces noise and vibration. The floor plate can be removed without tools for excellent, fast service access.

Intellix Vehicle System Management (VSM)

The VSM acts as a master truck controller, providing extensive monitoring and control of truck functions and systems. CANbus technology reduces wiring complexity and enables comprehensive communications between truck systems. The ergonomically positioned dash display transmits continual feedback to the operator and allows for the communication of service codes and comprehensive on-board diagnostics enable quick and easy troubleshooting. The electrical system features sealed connectors and Hall Effect sensors for superior dependability.

Hydraulic System

The hydraulic system incorporates a gear type pump, cast iron body for quiet efficiency. The system is protected from

GCVX series

Models: GLC 40VX, GLC 45VX, GLC 55VX, GLC 55SVX



HYSTER-YALE UK LIMITED

trading as **Yale Europe Materials Handling**
Centennial House, Frimley Business Park,
Frimley, Surrey GU16 7SG, United Kingdom.



Tel: +44 (0) 1276 538500
Fax: +44 (0) 1276 538559

www.yale-forklifts.eu



Publication part no. 220990374 Rev.04 Printed in The Netherlands (08418HG) EN.

Safety: This truck conforms to the current EU requirements. Specification is subject to change without notice.

Yale, VERACITOR and  are registered trademarks. "PEOPLE, PRODUCTS, PRODUCTIVITY", PREMIER, Hi-Vis, and CSS are trademarks in the United States and certain other jurisdictions. MATERIALS HANDLING CENTRAL and MATERIAL HANDLING CENTRAL are Service Marks in the United States and certain other jurisdictions.  is a Registered Copyright.

©Yale Europe Materials Handling 2018. All rights reserved. Truck shown with optional equipment.
Country of Registration: England and Wales. Company Registration Number: 02636775