



MP20-25T

SPEC SHEET

2,000 - 2,500 kg

MPT Series

Rider Pallet Truck

TRUCK DIMENSIONS – MPT SERIES

$$Ast = Wa + R + a$$

$$Ast = Wa + \sqrt{(l_6 - x)^2 + (b_{12} / 2)^2} + a$$

$$a = 200\text{mm}$$

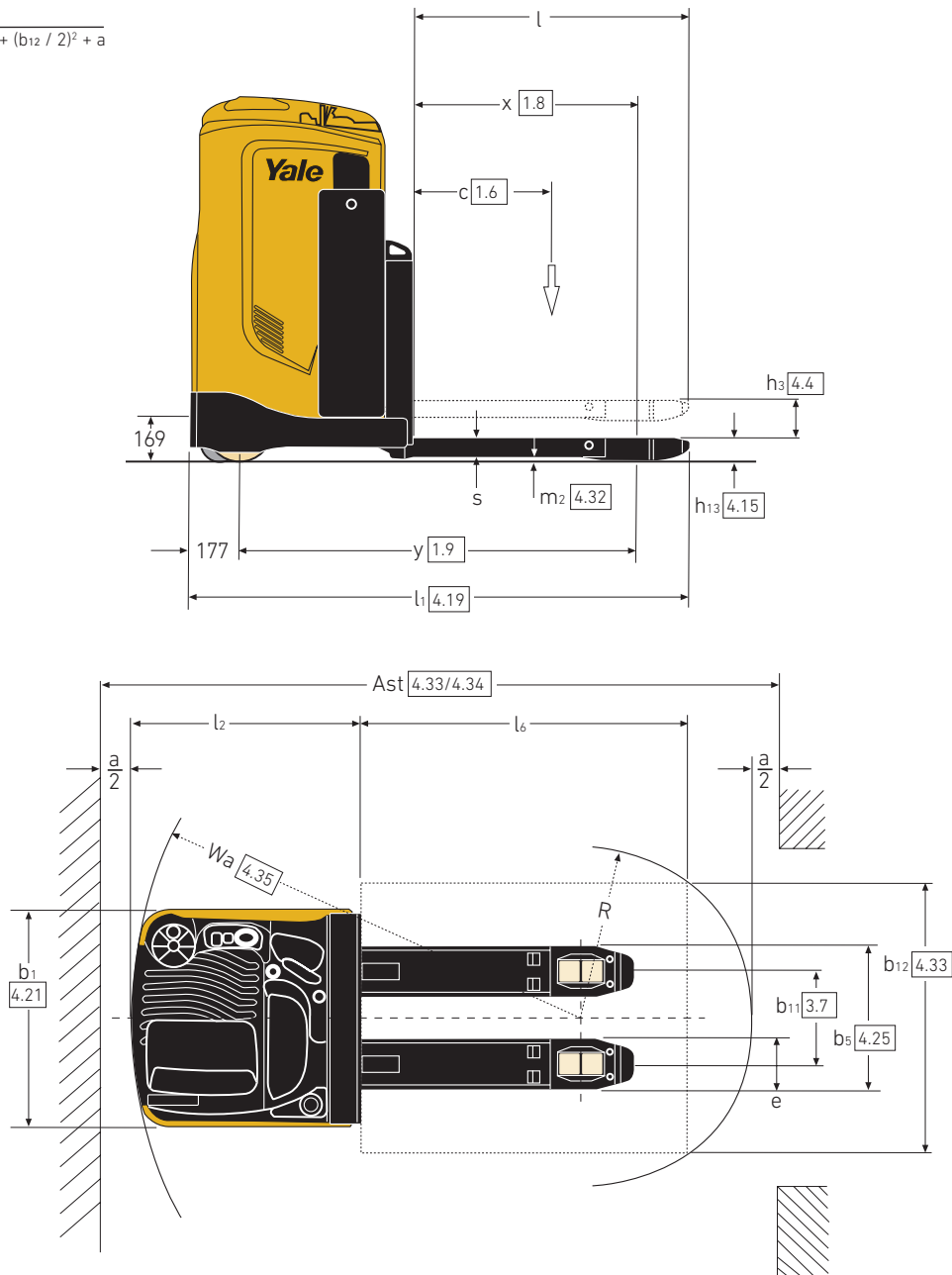

FORK DIMENSIONS – MPT SERIES

$b_5 = 480 - 530 - 560 - 670\text{mm}$
 $b_{11} = 296 - 346 - 376 - 486\text{mm}$

c (mm)	l (mm)	x (mm)	l-x (mm)	l ₆ (mm)	b ₁₂ ⁽⁴⁾ (mm)	R (mm)	y ⁽¹⁾ (mm)	l ₂ (mm)	l ₁ (mm)	Wa ⁽¹⁾ (mm)	a (mm)	Ast ⁽²⁾ (mm)	Fork weights ⁽³⁾ (kg)
500	1006	815	191	1000	800	441	1478	840	1846	1655	200	2296	147
600	1156	965	191	1200	1000	552	1628	840	1996	1805	200	2557	156
700	1406	965	441	1400	800	591	1628	840	2246	1805	200	2596	165
800	1596	1051	545	1600	800	679	1714	840	2436	1891	200	2770	173
1000	1956	1405	551	2000	1200	845	2068	840	2796	2245	200	3290	204.5
1100	2156	1405	751	2200	800	890	2068	840	2996	2245	200	3335	212.5
1200	2356	1405	951	2400	800	1072	2068	840	3196	2245	200	3517	220.5
1200	2356	1860	496	2400	800	672	2523	840	3196	2700	200	3572	229
1500	2856	1860	996	3000	1200	1288	2523	840	3696	2700	200	4188	249
1000	1956	1356	600	2000	1200	880	2019	840	2796	2196	200	3276	205.5
1100	2156	1356	800	2200	800	934	2019	840	2996	2196	200	3330	213.5
1200	2356	1650	706	2400	800	850	2313	840	3196	2490	200	3540	227

(1) With fork lowered - for forks raised -68mm

(2) Aisle width for pallets lengthwise

(3) All weights are: forks + tie rods

(4) $b_5 = 480 - 530 - 560 - 670\text{mm}$ / $b_{11} = 296 - 346 - 376 - 486\text{mm}$

VDI 2198 – GENERAL SPECIFICATIONS – MPT SERIES

		Yale		
		MP20T	MP25T	
GENERAL	1.1	Manufacturer		
	1.2	Model designation		
	1.3	Drive	Electric (battery)	
	1.4	Operator type	Stand	
	1.5	Rated capacity/Rated load	Q (t)	2000
	1.6	Load centre distance ⁽¹⁾	c (mm)	600 ⁽²⁾
	1.8	Load distance, centre of drive axle to fork ⁽¹⁾	x (mm)	965
	1.9	Wheelbase ⁽¹⁾	y (mm)	1628
	1.5	Rated capacity/Rated load		2500
WEIGHT	2.1	Service weight ⁽³⁾	kg	1010
	2.2	Axle loading, laden front/rear	kg	1202 / 1808
	2.3	Axle loading, unladen front/rear	kg	755 / 255
TYRES	3.1	Tyres front/rear		Vulkollan
	3.2	Tyre size, front	ø (mm x mm)	254 x 90
	3.3	Tyre size, rear	ø (mm x mm)	85 x 90
	3.4	Additional wheels (dimensions)	ø (mm x mm)	150 x 60
	3.5	Wheels, number front/rear (x = driven wheels)		1x + 1 / 4
	3.6	Tread, front	b ₁₀ (mm)	492
	3.7	Tread, rear ⁽¹⁾	b ₁₁ (mm)	346
DIMENSIONS	4.4	Lift	h ₃ (mm)	120
	4.8	Height of seat / platform	h ₇ (mm)	907 / 293
	4.15	Height, lowered	h ₁₃ (mm)	85
	4.19	Overall length ⁽¹⁾	l ₁ (mm)	1996
	4.20	Length to face of forks ⁽¹⁾	l ₂ (mm)	840
	4.21	Overall width	b ₁ /b ₂ (mm)	798
	4.22	Fork dimensions DIN ISO 2331 ⁽¹⁾	s/e/l (mm)	60 / 184 / 1156
	4.25	Distance over fork-arms ⁽¹⁾	b ₅ (mm)	530
	4.32	Ground clearance, centre of wheelbase	m ₂ (mm)	25
	4.33	Load dimension b ₁₂ x l ₆ lengthwise	b ₁₂ x l ₆ (mm)	800 x 1200
	4.34	Aisle width predetermined load dimensions	A _{st} (mm)	2465
	4.34.1	Aisle width for pallets 1000mm x 1200mm crossways ⁽¹⁾⁽³⁾	A _{st} (mm)	2557
	4.34.2	Aisle width for pallets 800mm x 1200mm lengthwise ⁽¹⁾⁽³⁾	A _{st} (mm)	2465
4.35	Turning radius ⁽¹⁾	W _a (mm)	1805	
PERFORMANCE	5.1	Travel speed, laden/unladen	km/h	9.5 / 12.5
	5.1.1	Travel speed, laden/unladen, backwards	km/h	9.5 / 9.5
	5.2	Lift speed, laden/unladen	m/s	0.027 / 0.037
	5.3	Lowering speed, laden/unladen	m/s	0.064 / 0.030
	5.8	Max. gradeability, laden/unladen	%	10.0 / 24.5
	5.10	Service brake		Electro Magnetic
ELECTRIC	6.1	Drive motor S2 60 minute rating	kW	2.6
	6.2	Lift motor; S3 15% rating	kW	1.2
	6.3	Battery according to DIN 43531/35/36 A,B,C, no		No
	6.4	Battery voltage/nominal capacity K5	(V)/(Ah)	24 / 465
	6.5	Battery weight ⁽⁴⁾	kg	366
	6.6	Energy consumption according to VDI cycle ⁽⁵⁾	kWh/h @ no. of cycles	0.4
8.1	Type of drive unit		AC Controller	
10.7	Sound pressure level at the driver's seat	dB (A)	69.5	

(1) See Forks table

(2) Applies to load length of 1200mm

(3) Stacking aisle width (lines 4.34.1 & 4.34.2) are based on the VDI standard calculation as shown on illustration. The British Industrial Truck Association recommends the addition of 100mm to the total clearance (dimension a) for extra operating margin at the rear of the truck.

(4) These values may vary of +/- 5%

(5) Values obtained with 40 cycles

All values are nominal values and they are subject to tolerances.



About Yale®

Yale Materials Handling Corporation is one of the oldest manufacturers of lift trucks in the world. We've been in the business of lifting since 1875 and we apply that experience to help customers solve materials handling challenges. Our full line of lift trucks range in capacity from 1 to 16 tonne and are powered by internal combustion engines or electric options. Yale also offers robotic solutions, telemetry, fleet management, parts, financing and training. From traditional lift truck equipment to emerging technologies, our goal, every day, is to work with our nationwide dealer network to continually improve and provide the solutions you need, when and how you need them.

MATERIALS HANDLING FOR:

3PL

Auto Parts

Beverage

Cold & Frozen Foods

Food Distribution

Food Processing

Furniture & Furnishings

Health & Pharma

Home Centres

Retail

E-Commerce

Yale Lift Truck Technologies

Centennial House
Frimley Business Park
Frimley
Surrey
GU16 7SG
United Kingdom

www.yale.com



Safety: All Yale products sold into EU countries, UK, and Turkey conform to the EU requirements of Machinery Directive 2006/42/EC and contain **CE** marking. Yale trucks sold into other countries may be ordered for production in conformance with Machinery Directive requirements, and when so ordered will contain **CE** marking.

HYSTER-YALE UK LIMITED trading as Yale Lift Truck Technologies. Registered Address: Centennial House, Building 4.5, Frimley Business Park, Frimley, Surrey, GU16 7SG, United Kingdom. Registered in England and Wales. Company Registration Number: 02636775.

©2023 Hyster-Yale Group, Inc., all rights reserved. YALE and YALE  are trademarks of Hyster-Yale Group, Inc. Trucks may be shown with optional equipment and/or features not available in all regions. Truck performance may be affected by the condition of the vehicle, how it is equipped and the application. Specifications are subject to change without notice.

Notice: Care must be exercised when handling elevated loads. Operators must be trained and must read, understand and follow the instructions contained in the Operating Manual. Consult your Yale® Dealer if any of the information shown is critical to your application.

Publication part no. 220991620 Rev.00 (0323DMS) EN