

MR series

1,400kg / 1,600kg / 2,000kg / 2,500kg

Reach Truck



- Complete AC infrastructure on drive, hoist and steering motors
- Standard and Premium touch screen display
- 180° and 360° steering at the touch of a button
- AccuTouch mini-lever module or joystick controls
- Vehicle Control Manager - VCM
- Dual CAN bus wiring

Truck Dimensions

Standard Cab

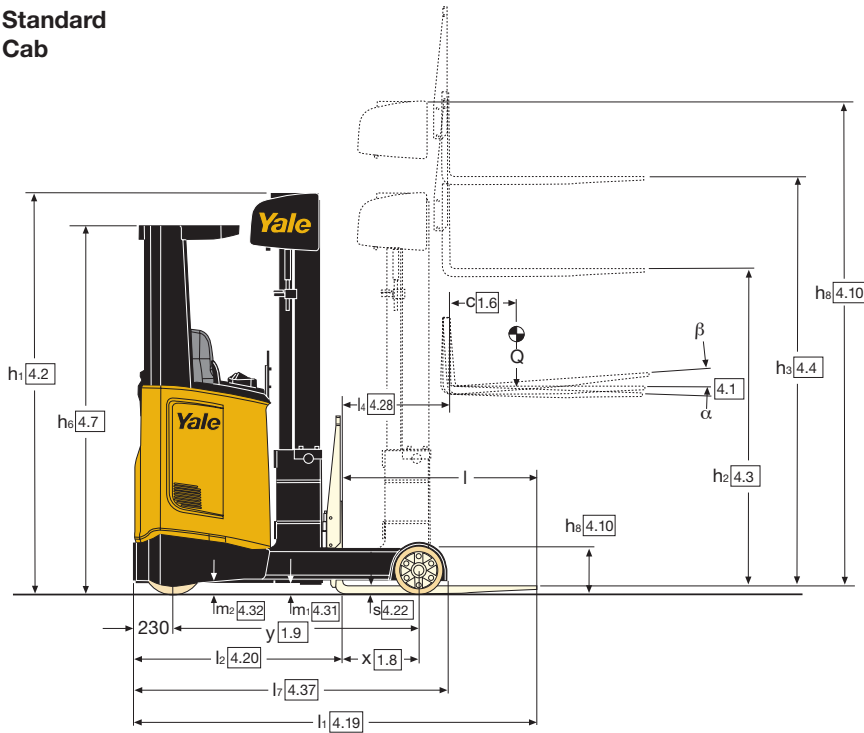

Standard Cab

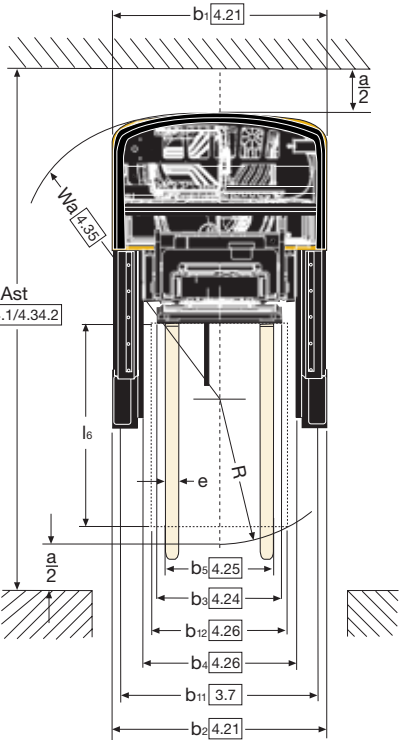
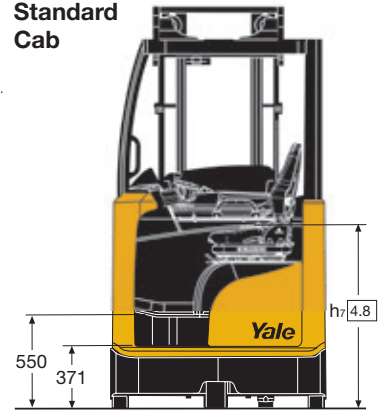

$A_{st} = Wa + R + a$
(See rows 4.34.1 and 4.34.2)

$$R = \sqrt{(l_6 - x)^2 + \left(\frac{b_{12}}{2}\right)^2}$$

$a = 200\text{mm}$

Cold Store Cab version

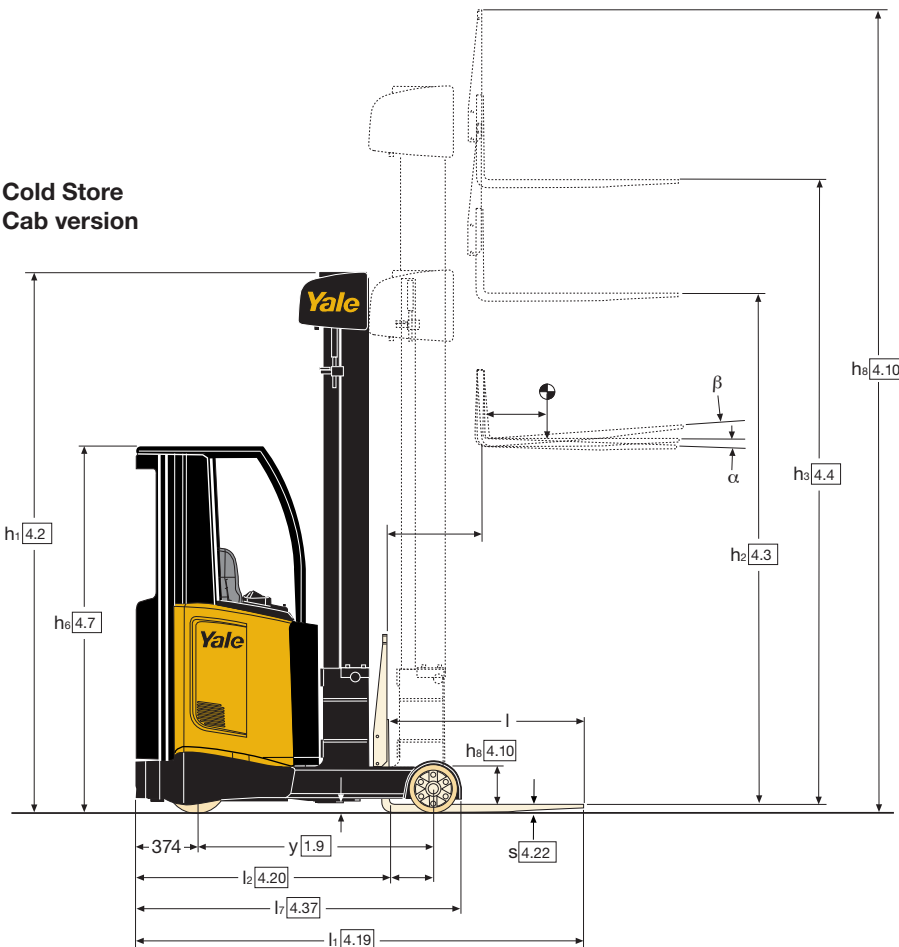

Cold Store Cab version

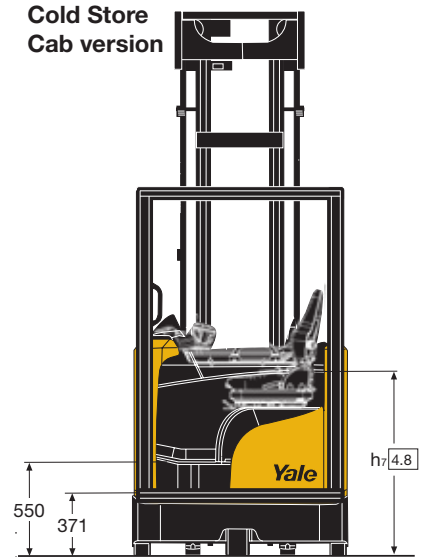

MR14, MR16, MR16N - Mast details, 3 stage full free lift (1,400kg / 1,600kg)

	Lift (h ₃) mm	Free lift (h ₂) mm	Height of mast lowered (h ₁) mm	Height of mast extended (h ₄) mm ⁽¹⁾	Weight kg ⁽²⁾
MR14, MR16 MR16N	5000	1648	2195	5563	911
	5250	1734	2281	5813	936
	5500	1820	2367	6063	961
	5750	1906	2453	6313	986
	6000	1992	2539	6563	1010
	6250	2078	2625	6813	1035
	6500	2164	2711	7063	1060
	6750	2250	2797	7313	1090
	7000	2336	2883	7563	1115
	7250	2422	2969	7813	1140
	7500	2508	3055	8063	1164
	7750	2594	3141	8313	1220
	8000	2680	3227	8563	1244
	8250	2766	3313	8813	1269
	8500	2852	3399	9063	1299
	8750	2938	3485	9313	1324
	9000	3024	3571	9563	1349
	9250	3110	3657	9813	1376
	9500	3196	3743	10063	1407
	9750	3282	3829	10313	1431
10000	3368	3915	10563	1460	
10250	3454	4001	10813	1485	
10500	3540	4087	11063	1509	

⁽¹⁾ With load backrest h₄ + 508mm.

⁽²⁾ All weights are: mast structures (weldment, cylinders, chain, pulley) + carriage + load backrest + oil. **Excluded:** forks, accessories.

MR20, MR25 - Mast details, 3 stage full free lift (2,000kg / 2,500kg)

	Lift (h ₃) mm	Free lift (h ₂) mm	Height of mast lowered (h ₁) mm	Height of mast extended (h ₄) mm ⁽¹⁾	Weight kg ⁽²⁾
	4650	1582	2195	5263	958
	4900	1668	2281	5513	985
	5150	1754	2367	5763	1012
	5400	1840	2453	6013	1038
	5650	1926	2539	6263	1065
	5900	2012	2625	6513	1092
	6150	2098	2711	6763	1118
	6400	2184	2797	7013	1150
	6650	2270	2883	7263	1177
	6900	2356	2969	7513	1204
	7150	2442	3055	7763	1230
	7400	2528	3141	8013	1288
	7650	2614	3227	8263	1314
	7900	2700	3313	8513	1341
	8150	2786	3399	8763	1373

⁽¹⁾ With load backrest h₄ + 443mm.

⁽²⁾ All weights are: mast structures (weldment, cylinders, chain, pulley) + carriage + load backrest + oil. **Excluded:** forks, accessories.

MR16HD - Mast details, Heavy Duty 3 stage full free lift (1,600kg)

	Lift (h ₃) mm	Free lift (h ₂) mm	Height of mast lowered (h ₁) mm	Height of mast extended (h ₄) mm ⁽¹⁾	Weight kg ⁽²⁾
	7900	2680	3227	8463	1376
	8150	2766	3313	8713	1404
	8400	2852	3399	8963	1438
	8650	2938	3485	9213	1467
	8900	3024	3571	9463	1495
	9150	3110	3657	9713	1523
	9400	3196	3743	9963	1558
	9650	3282	3839	10213	1586
	9900	3368	3925	10463	1649
	10150	3454	4011	10713	1677
	10400	3540	4097	10963	1706
	10650	3626	4183	11213	1734
	10900	3712	4269	11463	1763
	11150	3798	4355	11713	1791
	11400	3884	4441	11963	1819

⁽¹⁾ With load backrest h₄ + 508mm.

⁽²⁾ All weights are: mast structures (weldment, cylinders, chain, pulley) + carriage + load backrest + oil. **Excluded:** forks, accessories.

MR20HD - Mast details, Heavy Duty 3 stage full free lift (2,000kg)

Lift (h ₃) mm	Free lift (h ₂) mm	Height of mast lowered (h ₁) mm	Height of mast extended (h ₄) mm ⁽¹⁾	Weight kg ⁽²⁾
7750	2614	3227	8363	1402
8000	2700	3313	8613	1431
8250	2786	3399	8863	1465
8500	2872	3485	9113	1494
8750	2958	3571	9363	1523
9000	3044	3657	9613	1552
9250	3130	3743	9863	1587
9500	3216	3839	10113	1615
9750	3302	3925	10363	1678
10000	3388	4011	10613	1707
10250	3474	4097	10863	1736
10500	3560	4183	11113	1765
10750	3646	4269	11363	1793
11000	3732	4355	11613	1822
11250	3818	4441	11863	1851
11500	3904	4527	12113	1880
11750	3990	4613	12363	1908
12000	4076	4699	12613	1937
12250	4162	4785	12863	1966
12500	4248	4871	13113	1995
12750	4334	4957	13373	2024

⁽¹⁾ With load backrest h₄ + 443mm.

⁽²⁾ All weights are: mast structures (weldment, cylinders, chain, pulley) + carriage + load backrest + oil. **Excluded:** forks, accessories.

MR14, MR16, MR16N - Mast details, 4 stage full free lift (1,400kg / 1,600kg)

	Lift (h ₃) mm	Free lift (h ₂) mm	Height of mast lowered (h ₁) mm	Height of mast extended (h ₄) mm ⁽¹⁾	Weight kg ^{(2) (3)}	
MR14, MR16	MR16N	6650	1700	2280	7230	1014
		7050	1800	2380	7630	1046
		7450	1900	2480	8030	1078
		7850	2000	2580	8430	1110
		8050	2050	2630	8630	1126
		8300	2150	2730	8880	1158
	MR14	8500	2200	2780	9080	1207
		8700	2250	2830	9280	1223
		9150	2400	2980	9730	1271
		9400	2500	3080	9980	1303
		9850	2650	3230	10430	1351
		10050	2700	3280	10630	1367

⁽¹⁾ With load backrest 1000mm height, h₄ + 508 mm; with load backrest 1500mm height, h₄ + 1008mm.
Carriage set at 480mm from the ground.

⁽²⁾ All weights are: mast structures (weldment, cylinders, chain, pulley) + carriage + oil.
Excluded: forks, accessories.

⁽³⁾ With load backrest 700mm width, 1000mm height, weight + 13kg; with load backrest 700mm width, 1500mm height, weight + 21kg

MR14, MR16, MR16N - Mast details, 4 stage full free lift (2,000kg / 2,500kg)

	Lift (h ₃) mm	Free lift (h ₂) mm	Height of mast lowered (h ₁) mm	Height of mast extended (h ₄) mm ⁽¹⁾	Weight kg ^{(2) (3)}	
MR14, MR16	MR16	7050	1800	2380	7630	1295
		7450	1900	2480	8030	1335
		7850	2000	2580	8430	1375
		8050	2050	2630	8630	1395
		8300	2150	2730	8880	1435
		8500	2200	2780	9080	1490
	MR20HD	8700	2250	2830	9280	1510
		9150	2400	2980	9730	1570
		9400	2500	3080	9980	1610
		9850	2650	3230	10430	1670
		10050	2700	3280	10630	1690
		10300	2800	3380	10880	1730
		10500	2850	3430	11080	1750
10750	2950	3530	11330	1790		
11000	3050	3630	11580	1830		
11400	3150	3730	11980	1870		

⁽¹⁾ With load backrest 1000mm height, h₄ + 508 mm; with load backrest 1500mm height, h₄ + 1008mm.
Carriage set at 480mm from the ground.

⁽²⁾ All weights are: mast structures (weldment, cylinders, chain, pulley) + carriage + oil.

Excluded: forks, accessories.
⁽³⁾ With load backrest 700 mm width, 1000mm height, weight + 13kg; with load backrest 700mm width, 1500mm height, weight + 21kg.

All values are nominal values and they are subject to tolerances. For further information, please contact the manufacturer.

Yale products might be subject to change without notice.

Lift trucks illustrated may feature optional equipment.
Values may vary with alternative configurations.

MR14 truck dimensions for batteries

Distinguishing mark			MR14	MR14	MR14	MR14	MR14	MR14	
1.2	Manufacturer's type designation		MR14	MR14	MR14	MR14	MR14	MR14	
1.8	Load distance, centre of drive axle to fork	x (mm)	402	330	402	330	258	258	
1.9	Wheelbase	y (mm)	1400	1400	1400	1400	1400	1400	
Weights	2.1	Service weight	kg	3112	3309	3112	3320	3495	3541
	2.3	Axle loading, unladen front/rear ⁽⁵⁾	kg	1977 / 1135	2025 / 1285	1977 / 135	2032 / 1289	2055 / 1440	2084 / 1457
	2.4	Axle loading fork advanced, laden front/rear	kg	682 / 3830	792 / 3917	682 / 3830	800 / 3921	885 / 4010	914 / 4027
	2.5	Axle loading fork retracted, laden front/rear	kg	1778 / 2735	1753 / 2956	1778 / 2735	1760 / 2960	1711 / 3184	1741 / 3201
Dimensions	4.19	Overall length	l ₁ (mm)	2379	2451	2379	2451	2523	2523
	4.20	Length to face of forks	l ₂ (mm)	1229	1301	1229	1301	1373	1373
	4.28	Reach distance	l ₄ (mm)	585	513	585	513	441	441
	4.34.1	Aisle width for pallets 1000mm x 1200mm crossways	A _{st} (mm)	2718	2771	2718	2771	2828	2826
	4.34.2	Aisle width for pallets 800mm x 1200mm lengthways	A _{st} (mm)	2764	2829	2764	2829	2895	2895
	4.35	Turning radius	W _a (mm)	1671	1671	1671	1671	1671	1671
Electric-engine	6.3	Battery according to DIN 43531 / 35 / 36 A, B, C, no		C	C	C "Super"	C "Super"	C	C "Super"
	6.4	Battery voltage/nominal capacity K5	(V) / (Ah)	48 / 420	48 / 560 ⁽²⁾	48 / 465	48 / 620 ⁽²⁾	48 / 700 ⁽³⁾	48 / 775 ⁽³⁾
	6.5	Battery weight ⁽⁴⁾	kg	750	939	750	950	1119	1165

MR16 truck dimensions for batteries

Distinguishing mark			MR16	MR16	MR16	MR16	MR16	MR16	
1.2	Manufacturer's type designation		MR16	MR16	MR16	MR16	MR16	MR16	
1.8	Load distance, centre of drive axle to fork	x (mm)	452	380	452	380	308	308	
1.9	Wheelbase	y (mm)	1450	1450	1450	1450	1450	1450	
Weights	2.1	Service weight	kg	3162	3360	3162	3371	3546	3592
	2.3	Axle loading, unladen front/rear ⁽⁵⁾	kg	2018 / 1144	2069 / 1291	2018 / 1144	2077 / 1294	2103 / 1443	2133 / 1459
	2.4	Axle loading fork advanced, laden front/rear	kg	601 / 4162	714 / 4246	601 / 4162	721 / 4250	810 / 4336	839 / 4352
	2.5	Axle loading fork retracted, laden front/rear	kg	1853 / 2909	1825 / 3135	1853 / 2909	1832 / 3139	1779 / 3367	1809 / 3383
Dimensions	4.19	Overall length	l ₁ (mm)	2379	2451	2379	2451	2523	2523
	4.20	Length to face of forks	l ₂ (mm)	1229	1301	1229	1301	1373	1373
	4.28	Reach distance	l ₄ (mm)	635	563	635	563	491	491
	4.34.1	Aisle width for pallets 1000mm x 1200mm crossways	A _{st} (mm)	2731	2781	2731	2781	2834	2834
	4.34.2	Aisle width for pallets 800mm x 1200mm lengthways	A _{st} (mm)	2767	2830	2767	2830	2896	2896
	4.35	Turning radius	W _a (mm)	1718	1718	1718	1718	1718	1718
Electric-engine	6.3	Battery according to DIN 43531 / 35 / 36 A, B, C, no		C	C	C "Super"	C "Super"	C	C "Super"
	6.4	Battery voltage/nominal capacity K5	(V) / (Ah)	48 / 420	48 / 560 ⁽²⁾	48 / 465	48 / 620 ⁽²⁾	48 / 700 ⁽³⁾	48 / 775 ⁽³⁾
	6.5	Battery weight ⁽⁴⁾	kg	750	939	750	950	1119	1165

MR16N truck dimensions for batteries

Distinguishing mark			MR16N	MR16N	MR16N	MR16N	MR16N	MR16N	
1.2	Manufacturer's type designation		MR16N	MR16N	MR16N	MR16N	MR16N	MR16N	
1.8	Load distance, centre of drive axle to fork	x (mm)	382	292	382	292	202	202	
1.9	Wheelbase	y (mm)	1450	1450	1450	1450	1450	1450	
Weights	2.1	Service weight	kg	3111	3309	3115	3317	3498	3514
	2.3	Axle loading, unladen front/rear ⁽⁵⁾	kg	1922 / 1189	1947 / 1362	1924 / 1191	1952 / 1365	1955 / 1543	1965 / 1549
	2.4	Axle loading fork advanced, laden front/rear	kg	569 / 4142	672 / 4237	572 / 4143	677 / 4240	757 / 4341	766 / 4347
	2.5	Axle loading fork retracted, laden front/rear	kg	1680 / 3032	1606 / 3303	1682 / 3033	1611 / 3306	1514 / 3584	1524 / 3590
Dimensions	4.19	Overall length	l ₁ (mm)	2449	2539	2449	2539	2629	2629
	4.20	Length to face of forks	l ₂ (mm)	1299	1389	1299	1389	1479	1479
	4.28	Reach distance	l ₄ (mm)	565	475	565	475	385	385
	4.34.1	Aisle width for pallets 1000mm x 1200mm crossways	A _{st} (mm)	2762	2828	2762	2828	2898	2899
	4.34.2	Aisle width for pallets 800mm x 1200mm lengthways	A _{st} (mm)	2811	2893	2811	2893	2976	2976
	4.35	Turning radius	W _a (mm)	1700	1700	1700	1700	1700	1700
Electric-engine	6.3	Battery according to DIN 43531 / 35 / 36 A, B, C, no		B	B	B "Super"	B "Super"	C	B "Super"
	6.4	Battery voltage/nominal capacity K5	(V) / (Ah)	48 / 420	48 / 560	48 / 465	48 / 620	48 / 700	48 / 775
	6.5	Battery weight ⁽⁴⁾	kg	746	937	750	945	1119	1135

MR16HD truck dimensions for batteries

Distinguishing mark			MR16HD	MR16HD	MR16HD	MR16HD	
1.2	Manufacturer's type designation		MR16HD	MR16HD	MR16HD	MR16HD	
1.8	Load distance, centre of drive axle to fork	x (mm)	293	293	293	293	
1.9	Wheelbase	y (mm)	1450	1450	1450	1450	
Weights	2.1	Service weight	kg	4038	4049	4224	4270
	2.3	Axle loading, unladen front/rear ⁽⁵⁾	kg	2417 / 1621	2424 / 1625	2428 / 1796	2457 / 1813
	2.4	Axle loading fork advanced, laden front/rear	kg	883 / 4755	891 / 4758	979 / 4845	1009 / 4861
	2.5	Axle loading fork retracted, laden front/rear	kg	2172 / 3466	2180 / 3469	2104 / 3720	2134 / 3736
Dimensions	4.19	Overall length	l ₁ (mm)	2523	2523	2523	2523
	4.20	Length to face of forks	l ₂ (mm)	1388	1388	1388	1388
	4.28	Reach distance	l ₄ (mm)	491	491	491	491
	4.34.1	Aisle width for pallets 1000mm x 1200mm crossways	A _{st} (mm)	2845	2845	2845	2845
	4.34.2	Aisle width for pallets 800mm x 1200mm lengthways	A _{st} (mm)	2909	2909	2909	2909
	4.35	Turning radius	W _a (mm)	1718	1718	1718	1718
Electric-engine	6.3	Battery according to DIN 43531 / 35 / 36 A, B, C, no		C	C "Super"	C	C "Super"
	6.4	Battery voltage/nominal capacity K5	(V) / (Ah)	48 / 560 ⁽²⁾	48 / 620 ⁽²⁾	48 / 700 ⁽³⁾	48 / 775 ⁽³⁾
	6.5	Battery weight ⁽⁴⁾	kg	939	950	1119	1165

MR20 truck dimensions for batteries

Distinguishing mark			MR20	MR20	MR20	MR20	
1.2	Manufacturer's type designation		MR20	MR20	MR20	MR20	
1.8	Load distance, centre of drive axle to fork	x (mm)	415	415	343	343	
1.9	Wheelbase	y (mm)	1500	1500	1500	1500	
Weights	2.1	Service weight	kg	3615	3626	3801	3847
	2.3	Axle loading, unladen front/rear ⁽⁵⁾	kg	2261 / 1354	2268 / 1358	2296 / 1504	2326 / 1520
	2.4	Axle loading fork advanced, laden front/rear	kg	671 / 4943	679 / 4947	770 / 5030	801 / 5046
	2.5	Axle loading fork retracted, laden front/rear	kg	2032 / 3583	2039 / 3586	1971 / 3829	2002 / 3845
Dimensions	4.19	Overall length	l ₁ (mm)	2451	2451	2523	2523
	4.20	Length to face of forks	l ₂ (mm)	1316	1316	1388	1388
	4.28	Reach distance	l ₄ (mm)	613	613	541	541
	4.34.1	Aisle width for pallets 1000mm x 1200mm crossways	A _{st} (mm)	2805	2805	2857	2857
	4.34.2	Aisle width for pallets 800mm x 1200mm lengthways	A _{st} (mm)	2848	2848	2913	2912
	4.35	Turning radius	W _a (mm)	1767	1767	1767	1767
Electric-engine	6.3	Battery according to DIN 43531 / 35 / 36 A, B, C, no		C	C "Super"	C	C "Super"
	6.4	Battery voltage/nominal capacity K5	(V) / (Ah)	48 / 560 ⁽²⁾	48 / 620 ⁽²⁾	48 / 700 ⁽³⁾	48 / 775 ⁽³⁾
	6.5	Battery weight ⁽⁴⁾	kg	939	950	1119	1165

MR20HD truck dimensions for batteries

Distinguishing mark			MR20HD	MR20HD	MR20HD	MR20HD	
1.2	Manufacturer's type designation		MR20HD	MR20HD	MR20HD	MR20HD	
1.8	Load distance, centre of drive axle to fork	x (mm)	338	338	266	266	
1.9	Wheelbase	y (mm)	1500	1500	1500	1500	
Weights	2.1	Service weight	kg	4425	4471	4617	4679
	2.3	Axle loading, unladen front/rear ⁽⁵⁾	kg	2567 / 1858	2597 / 1874	2577 / 2040	2616 / 2063
	2.4	Axle loading fork advanced, laden front/rear	kg	891 / 5534	921 / 5550	985 / 5632	1024 / 5655
	2.5	Axle loading fork retracted, laden front/rear	kg	2235 / 4189	2266 / 4205	2149 / 4468	2189 / 4490
Dimensions	4.19	Overall length	l ₁ (mm)	2528	2528	2600	2600
	4.20	Length to face of forks	l ₂ (mm)	1393	1393	1465	1465
	4.28	Reach distance	l ₄ (mm)	536	536	464	464
	4.34.1	Aisle width for pallets 1000mm x 1200mm crossways	A _{st} (mm)	2860	2860	2915	2915
	4.34.2	Aisle width for pallets 800mm x 1200mm lengthways	A _{st} (mm)	2917	2917	2983	2983
	4.35	Turning radius	W _a (mm)	1767	1767	1767	1767
Electric-engine	6.3	Battery according to DIN 43531 / 35 / 36 A, B, C, no		C	C "Super"	C	C "Super"
	6.4	Battery voltage/nominal capacity K5	(V) / (Ah)	48 / 700 ⁽³⁾	48 / 775 ⁽³⁾	48 / 840	48 / 930
	6.5	Battery weight ⁽⁴⁾	kg	1119	1165	1306	1368

MR25 truck dimensions for batteries

Distinguishing mark			MR25	MR25	MR25	MR25	
1.2	Manufacturer's type designation		MR25	MR25	MR25	MR25	
1.8	Load distance, centre of drive axle to fork	x (mm)	488	488	416	416	
1.9	Wheelbase	y (mm)	1650	1650	1650	1650	
Weights	2.1	Service weight	kg	4038	4084	4230	4292
	2.3	Axle loading, unladen front/rear ⁽⁵⁾	kg	2520 / 1518	2552 / 1532	2565 / 1665	2606 / 1686
	2.4	Axle loading fork advanced, laden front/rear	kg	773 / 5765	804 / 5780	876 / 5855	917 / 5875
	2.5	Axle loading fork retracted, laden front/rear	kg	2371 / 4167	2402 / 4182	2306 / 4424	2348 / 4444
Dimensions	4.19	Overall length	l ₁ (mm)	2528	2528	2600	2600
	4.20	Length to face of forks	l ₂ (mm)	1393	1393	1465	1465
	4.28	Reach distance	l ₄ (mm)	686	686	614	614
	4.34.1	Aisle width for pallets 1000mm x 1200mm crossways	A _{st} (mm)	2900	2900	2949	2948
	4.34.2	Aisle width for pallets 800mm x 1200mm lengthways	A _{st} (mm)	2927	2927	2991	2991
	4.35	Turning radius	W _a (mm)	1911	1911	1911	1911
Electric-engine	6.3	Battery according to DIN 43531 / 35 / 36 A, B, C, no		C	C "Super"	C	C "Super"
	6.4	Battery voltage/nominal capacity K5	(V) / (Ah)	48 / 700 ⁽³⁾	48 / 775 ⁽³⁾	48 / 840	48 / 930
	6.5	Battery weight ⁽⁴⁾	kg	1119	1165	1306	1368

⁽¹⁾ These values may vary of +/- 5%.

⁽²⁾ Available Li-Ion battery 48V / 450Ah (895kg)

⁽³⁾ Available Li-Ion battery 48V / 450Ah (1067 / 1068kg); Li-Ion battery 48V / 600Ah (1091kg)

⁽⁴⁾ Forks retracted.

⁽⁵⁾ For A_{st} with mast 4 stage, see "Mast table 4 stage 14-16" and "Mast table 4 stage 20-25"

All weights (2.1 to 2.5) are with lowest mast and standard forks.

All values are nominal values and they are subject to tolerances. For further information, please contact the manufacturer.

Yale products might be subject to change without notice.

Lift trucks illustrated may feature

optional equipment.

Values may vary with alternative configurations.

Standard equipment and options

MR14/16 MR16N MR20/25 MR16HD MR20HD

	MR14/16	MR16N	MR20/25	MR16HD	MR20HD	
Operator Compartment	Intermediate step	■	■	■	■	■
	Grab handle on overhead guard post	■	■	■	■	■
	Grab handle under armrest	■	■	■	■	■
	AccuTouch mini-levers mounted on adjustable length armrest	■	■	■	■	■
	Joystick mounted on adjustable length armrest	○	○	○	○	○
	Full suspension seat - 60mm suspension travel cloth upholstery	■	■	■	■	■
	Full suspension seat - 80mm suspension travel cloth upholstery	○	○	○	○	○
	Headrest (cloth version only)	○	○	○	○	○
	Synchronised seat cushion and backrest movement (cloth version only)	○	○	○	○	○
	Seat belt	○	○	○	○	○
	Heated seat	○	○	○	○	○
	Antistatic seat (cloth version only)	○	○	○	○	○
	Vinyl seat upholstery	○	○	○	○	○
	Standard display	■	■	■	■	■
	Premium display with touch screen	○	○	○	○	○
	Keyless access	○	○	○	○	○
	Adjustable steering column	■	■	■	■	■
	Automatic park brake Yalestop	■	■	■	■	■
180° steering	■	■	■	■	■	
360° steering	○	○	○	○	○	
Driver select steering mode 180 / 360° (push button)	○	○	○	○	○	
Travel performance	Travel speed 11km/h	■	■	+	+	+
	Travel speed 14km/h with electric load wheel braking	○	○	■	■	■
	Speed slow down mast reached forward	■	■	■	■	■
	Speed slow down on cornering	■	■	■	■	■
	Speed slow down over free lift	■	■	■	■	■
Lift performance / driver assist	3 stage mast / tilting carriage	■	■	■	■	■
	Simultaneous lift / reach functionality	■	■	■	■	■
	Simultaneous hydraulic functionality - 3 functions	○	○	○	○	○
	Mast cushioning over free lift/main lift sections - fixed sensor mounting	■	■	■	■	+
	Lift Comfort package ⁽¹⁾	○	○	○	■	■
	Lift Performance package	○	○	+	■	■
	Laser line fork positioning aid (above free lift)	○	○	○	○	○
	Auto side shift centring	○	○	○	○	○
	Auto fork levelling in the horizontal position	○	○	○	○	○
	Height preselector (with/without pallet detection device)	○	○	○	○	○
	Fork mounted camera / monitor	○	○	○	○	○
Weight indicator	○	○	○	○	○	
Application environment	5th hydraulic function	○	○	○	○	○
	Universal support bracket	○	○	○	○	○
	Beverage holder and document tray	○	○	○	○	○
	A4 clipboard	○	○	○	○	○
	Stretch film roll holder	○	○	○	○	○
	Lift limit with override (1 x height setting)	○	○	○	○	○
	Lift limit with override (2 x height settings)	○	○	○	○	○
	Lower limit (with override option)	○	○	○	○	○
	Flashing beacon	○	○	○	○	○
	Work lights x 2 (mast side)	○	○	○	○	○
	Work lights x 2 (drive side)	○	○	○	○	○
	Polycarbonate (lexan) protection on overhead guard	○	○	○	○	○
	Metal grid protection on overhead guard	○	○	○	○	○
	Top / front load wheel protection	■	■	■	■	■
	Side load wheel protection	○	○	○	○	○
	High temperature environment	○	○	○	○	○
	Side battery change - battery tray rollers	○	○	○	○	○
	Side battery change table	○	○	○	○	○
	Extension cable	○	○	○	○	○
	Drive-in overhead guard (w900 x h1400 / w900 x h1700 mm)	○	○	○	○	○
	Antistatic drive and load wheels	○	○	○	○	○
Wet surface drive and load wheels	○	○	○	○	○	
Side guidance rollers	○	○	MR20	○	○	
DC/DC converter (choice of 12V/ 48V, 24V / 48V, 12-24V / 48V options)	○	○	○	○	○	
Audible alarm (choice of forks leading, forks trailing, both travel directions)	○	○	○	○	○	
Load backrest (choice of heights 1000 / 1500 mm)	○	○	○	○	○	
Chassis / Battery sizes	Chassis width (max) 1265 mm	■	+	MR20	■	+
	1125 mm	+	■	+	+	+
	1345 mm	+	+	MR25	+	○
	Battery sizes ⁽²⁾ 420 - 465 Ah	○	○	+	+	+
	560 - 620 Ah	○	○	○ MR20	○	+
	700 - 775 Ah	○	○	○	○	○
840 - 930 Ah	+	+	○ MR25	+	○	

⁽¹⁾ Includes; End of stroke slow down on lift. Soft stop on lowering. Height controlled mast cushioning over Free Lift/Main lift mast section. Height indicator. ⁽²⁾ DIN C battery on MR14 /MR16 /MR20 / MR25 /MR16HD/MR20HD. DIN B battery on MR16N. ■ Standard ○ Optional + Not available

VDI 2198 General Specifications - MR14, MR16, MR16N, MR16HD, MR20, MR20HD, MR25

Distinguishing mark	1.1	Manufacturer (abbreviation)		Yale	Yale	Yale	
	1.2	Manufacturer's type designation		MR14	MR16	MR16N	
	1.3	Drive: electric (battery or mains), diesel, petrol, fuel gas		Electric (Battery)	Electric (Battery)	Electric (Battery)	
	1.4	Operator type: hand, pedestrian, standing, seated, order-picker		Seated	Seated	Seated	
	1.5	Rated capacity/Rated load	Q (kg)	1400	1600	1600	
	1.6	Load centre distance	c (mm)	600	600	600	
	1.8	Load distance, centre of drive axle to fork ⁽⁹⁾ ⁽¹⁰⁾	x (mm)	258	308	202	
	1.9	Wheelbase	y (mm)	1400	1450	1450	
	Weights	2.1	Service weight	kg	3495	3546	3498
2.3		Axle loading, unladen front/rear ⁽⁵⁾	kg	2055 / 1440	2103 / 1443	1955 / 1543	
2.4		Axle loading fork advanced, laden front/rear	kg	885 / 4010	810 / 4336	757 / 4341	
2.5		Axle loading fork retracted, laden front/rear	kg	1711 / 3184	1779 / 3367	1514 / 3584	
Tyres/chassis		3.1	Tyres: polyurethane, tophane, NDIIThane, front/rear		NDIIThane / NDIIThane	NDIIThane / NDIIThane	NDIIThane / NDIIThane
	3.2	Tyre size, front	ø mm x mm	343 x 140	343 x 140	343 x 140	
	3.3	Tyre size, rear	ø mm x mm	285 x 100	285 x 100	285 x 100	
	3.5	Wheels, number front/rear (x = driven wheels)		1 x / 2	1 x / 2	1 x / 2	
	3.7	Tread, rear	b ₁₁ (mm)	1155	1155	1025	
	Dimensions	4.1	Tilt of mast/fork carriage forward/backward	α / β (°)	2 / 4	2 / 4	2 / 4
		4.2	Height of mast, lowered	h ₁ (mm)	2195	2195	2195
4.3		Free lift	h ₂ (mm)	1648	1648	1648	
4.4		Lift	h ₃ (mm)	5000	5000	5000	
4.5		Height, mast extended ⁽¹⁾	h ₄ (mm)	5563	5563	5563	
4.7		Height of overhead guard (cabin) ⁽²⁾	h ₆ (mm)	2175	2175	2175	
4.8		Seat height relating to SIP	h ₇ (mm)	1082	1082	1082	
4.10		Height of wheel arms	h ₈ (mm)	308	308	308	
4.19		Overall length	l ₁ (mm)	2523	2523	2629	
4.20		Length to face of forks	l ₂ (mm)	1373	1373	1479	
4.21		Overall width ⁽³⁾	b ₁ / b ₂ (mm)	1265	1265	1125	
4.22		Fork dimensions DIN ISO 2331	s/e/l (mm)	40 / 80 / 1150	40 / 120 / 1150	40 / 120 / 1150	
4.23		Fork carriage ISO 2328, class/type A, B		2A	2A	2A	
4.24		Fork-carriage width	b ₃ (mm)	700	700	700	
4.25		Distance between fork-arms min/max ⁽⁶⁾	b ₅ (mm)	220 / 640	260 / 680	260 / 680	
4.26		Distance between wheel arms/loading surfaces	b ₄ (mm)	900	900	795	
4.28		Reach distance	l ₄ (mm)	441	491	385	
4.31		Ground clearance, laden, below mast	m ₁ (mm)	75	75	65	
4.32		Ground clearance, centre of wheelbase	m ₂ (mm)	75	75	65	
4.34.1		Aisle width for pallets 1000mm x 1200mm crossways ⁽¹¹⁾	A _{st} (mm)	2828	2834	2898	
4.34.2		Aisle width for pallets 800mm x 1200mm lengthwise ⁽¹¹⁾	A _{st} (mm)	2895	2896	2976	
4.35	Turning radius	W _a (mm)	1671	1718	1700		
4.37	Length across wheel arms	l ₇ (mm)	1795	1845	1845		
4.42	Step height (from ground to running board)	mm	550	550	550		
4.43	Step height (between intermediate steps between running board and floor)	mm	371	371	371		
Performance data	5.1	Travel speed, laden/unladen ⁽⁷⁾	km/h	11 / 11 (14 / 14)	11 / 11 (14 / 14)	11 / 11 (14 / 14)	
	5.1.1	Travel speed, laden/unladen, backwards ⁽⁷⁾	km/h	11 / 11 (14 / 14)	11 / 11 (14 / 14)	11 / 11 (14 / 14)	
	5.2	Lift speed, laden/unladen ⁽⁷⁾	m/s	0,37 / 0,63 (0,47 / 0,73)	0,32 / 0,63 (0,42 / 0,73)	0,32 / 0,63 (0,42 / 0,73)	
	5.3	Lowering speed, laden/unladen	m/s	0.55	0.55	0.55	
	5.4	Reaching speed, laden/unladen	m/s	0,17 / 0,17	0,17 / 0,17	0,17 / 0,17	
	5.7	Gradeability, laden/unladen	%	10 / 15	10 / 15	10 / 15	
	5.8	Max. gradeability laden/unladen	%	10 / 15	10 / 15	10 / 15	
	5.9	Acceleration time laden/unladen ⁽⁷⁾	s	3,3 / 3,3 (2,6 / 2,6)	3,4 / 3,4 (2,7 / 2,7)	3,4 / 3,4 (2,7 / 2,7)	
	5.10	Service brake		Electric	Electric	Electric	
	Electric-engine	6.1	Drive motor S2 60 minute rating	kW	6.4	6.4	6.4
6.2		Lift motor, S3 15% rating	kW	14	14	14	
6.3		Battery according to DIN 43531 / 35 / 36 A,B,C, no		C	C	B	
6.4		Battery voltage/nominal capacity Ks	(V) / (Ah)	48 / 700 ⁽⁶⁾	48 / 700 ⁽⁶⁾	48 / 700 (6)	
6.5		Battery weight ⁽⁴⁾	kg	1119	1119	1119	
6.6		Energy consumption according to VDI cycle	kWh @ Nr of Cycles	3.8	4.0	4.0	
Addition data	8.1	Type of drive unit		AC-Controller	AC-Controller	AC-Controller	
	10.1	Operating pressure for attachments	bar	180	180	180	
	10.2	Oil volume for attachment	l/min	20	20	20	
	10.7	Sound pressure level at the driver's seat	dB (A)	<69.7	<69.7	<69.7	

⁽¹⁾ With load backrest h4 + 508 mm MR14 / MR16 / MR16N / MR16HD), + 443mm (MR20 / MR25 / MR20HD).
⁽²⁾ With beacon h6 + 120mm.; With OHG Grid Protector h6 + 20mm; With OHG Screen

Protector h6 + 30 mm.
⁽³⁾ With load wheels lateral covers: 1289mm (MR14 / MR16 / MR20 / MR16HD), 1153mm (MR16N), 1373mm (MR25 / MR20HD).

⁽⁴⁾ These values may vary of +/- 5%.
⁽⁵⁾ Forks retracted.
⁽⁶⁾ See Batteries table.
⁽⁷⁾ Values in brackets are optional.

⁽⁸⁾ Side shift stroke is +/-75mm on all trucks. Reduced to +/-25mm for MR16N.
⁽⁹⁾ For models MR14-16 with mast 4 stage: x - 53mm
⁽¹⁰⁾ For models MR20-25 with mast 4 stage: x - 108mm.

Yale	Yale	Yale	Yale		Manufacturer (abbreviation)	1.1	Distinguishing mark
MR16HD	MR20	MR20HD	MR25		Manufacturer's type designation	1.2	
Electric (Battery)	Electric (Battery)	Electric (Battery)	Electric (Battery)		Drive: electric (battery or mains), diesel, petrol, fuel gas	1.3	
Seated	Seated	Seated	Seated		Operator type: hand, pedestrian, standing, seated, order-picker	1.4	
1600	2000	2000	2500	Q (kg)	Rated capacity/Rated load	1.5	
600	600	600	600	c (mm)	Load centre distance	1.6	
293	343	266	416	x (mm)	Load distance, centre of drive axle to fork (9) (10)	1.8	
1450	1500	1500	1650	y (mm)	Wheelbase	1.9	
4224	3801	4617	4230	kg	Service weight	2.1	
2428 / 1796	2296 / 1504	2577 / 2040	2565 / 1665	kg	Axle loading, unladen front/rear ⁽⁹⁾	2.3	
979 / 4845	770 / 5030	985 / 5632	876 / 5855	kg	Axle loading fork advanced, laden front/rear	2.4	
2104 / 3720	1971 / 3829	2149 / 4468	2306 / 4424	kg	Axle loading fork retracted, laden front/rear	2.5	
NDIIThane / NDIIThane	NDIIThane / NDIIThane	NDIIThane / NDIIThane	NDIIThane / NDIIThane		Tyres: polyurethane, tophane, NDIIThane, front/rear	3.1	
343 x 140	343 x 140	343 x 140	343 x 140	ø mm x mm	Tyre size, front	3.2	
285 x 100	285 x 100	285 x 140	285 x 140	ø mm x mm	Tyre size, rear	3.3	
1 x / 2	1x/ 2	1 x / 2	1x/ 2		Wheels, number front/rear (x = driven wheels)	3.5	
1155	1155	1195	1195	b11 (mm)	Tread, rear	3.7	
2 / 4	2 / 4	2 / 4	2 / 4	α / β (°)	Tilt of mast/fork carriage forward/backward	4.1	
3227	2195	3227	2195	h1 (mm)	Height of mast, lowered	4.2	
2680	1582	2614	1582	h2 (mm)	Free lift	4.3	
7900	4650	7750	4650	h3 (mm)	Lift	4.4	
8463	5263	8363	5263	h4 (mm)	Height, mast extended ⁽¹⁾	4.5	
2175	2175	2175	2175	h6 (mm)	Height of overhead guard (cabin) ⁽²⁾	4.7	
1082	1082	1082	1082	h7 (mm)	Seat height relating to SIP	4.8	
308	308	308	308	h8 (mm)	Height of wheel arms	4.10	
2523	2523	2600	2600	l1 (mm)	Overall length	4.19	
1388	1388	1465	1465	l2 (mm)	Length to face of forks	4.20	
1265	1265	1345	1345	b1 /b2 (mm)	Overall width (3)	4.21	
40 / 120 / 1150	40 / 120 / 1150	45 / 120 / 1150	45 / 120 / 1150	s/e/l (mm)	Fork dimensions DIN ISO 2331	4.22	
2A	2A	2A	2A		Fork carriage ISO 2328, class/type A, B	4.23	
700	700	700	700	b3 (mm)	Fork-carriage width	4.24	
260 / 680	260 / 680	260 / 680	260 / 680	b5 (mm)	Distance between fork-arms min/max ⁽⁹⁾	4.25	
900	900	900	900	b4 (mm)	Distance between wheel arms/loading surfaces	4.26	
491	541	464	614	l4 (mm)	Reach distance	4.28	
65	65	65	65	m1 (mm)	Ground clearance, laden, below mast	4.31	
65	65	65	65	m2 (mm)	Ground clearance, centre of wheelbase	4.32	
2845	2857	2915	2949	A _{st} (mm)	Aisle width for pallets 1000mm x 1200mm crossways ⁽¹¹⁾	4.34.1	
2909	2913	2983	2991	A _{st} (mm)	Aisle width for pallets 800mm x 1200mm lengthwise ⁽¹¹⁾	4.34.2	
1718	1767	1767	1911	W _a (mm)	Turning radius	4.35	
1845	1895	1895	2045	l7 (mm)	Length across wheel arms	4.37	
550	550	550	550	mm	Step height (from ground to running board)	4.42	
371	371	371	371	mm	Step height (between intermediate steps between running board and floor)	4.43	
14 / 14	14 / 14	14 / 14	14 / 14	km/h	Travel speed, laden/unladen ⁽⁷⁾	5.1	
14 / 14	14 / 14	14 / 14	14 / 14	km/h	Travel speed, laden/unladen, backwards ⁽⁷⁾	5.1.1	
0,42 / 0,73	0,37 / 0,64	0,37 / 0,68	0,30 / 0,64	m/s	Lift speed, laden/unladen ⁽⁷⁾	5.2	
0.55	0,55 / 0,50	0.55	0,55 / 0,50	m/s	Lowering speed, laden/unladen	5.3	
0,17 / 0,17	0,17 / 0,17	0,17 / 0,17	0,17 / 0,17	m/s	Reaching speed, laden/unladen	5.4	
10 / 14	10 / 15	8 / 13	8 / 14	%	Gradeability, laden/unladen	5.7	
10 / 15	10 / 15	10 / 15	10 / 15	%	Max. gradeability laden/unladen	5.8	
2,6 / 2,5	2,6 / 2,5	2,7 / 2,6	2,7 / 2,6	s	Acceleration time laden/unladen ⁽⁷⁾	5.9	
Electric	Electric	Electric	Electric		Service brake	5.10	
6.4	6.4	6.4	6.4	kW	Drive motor S2 60 minute rating	6.1	
14	14	14	14	kW	Lift motor, S3 15% rating	6.2	
C	C	C	C		Battery according to DIN 43531 / 35 / 36 A,B,C, no	6.3	
48 / 700 ⁽⁶⁾	48 / 700 ⁽⁶⁾	48 / 840 ⁽⁶⁾	48 / 840 ⁽⁶⁾	(V) / (Ah)	Battery voltage/nominal capacity K5	6.4	
1119	1119	1306	1306	kg	Battery weight ⁽⁴⁾	6.5	
4.2	4.6	4.8	5.2	kWh/h @ Nr of Cycles	Energy consumption according to VDI cycle	6.6	
AC-Controller	AC-Controller	AC-Controller	AC-Controller		Type of drive unit	8.1	
180	180	180	180	bar	Operating pressure for attachments	10.1	
20	20	20	20	l/min	Oil volume for attachment	10.2	
<69.7	<69.7	<69.7	<69.7	dB (A)	Sound pressure level at the driver's seat	10.7	

⁽¹¹⁾ For Ast with mast 4 stage, see 'Mast table 4 stage 14-16' and 'Mast table 4 stage 20-25' MR16N.

All values are nominal values and they are subject to tolerances. For further information, please contact the manufacturer.

Yale products might be subject to change

without notice. Lift trucks illustrated may feature optional equipment. Values may vary with alternative configurations.

MR14 Cold Store Cabin dimensions

1.8	Load distance, centre of drive axle to fork	x (mm)	330	330	330	330	258	258
1.9	Wheelbase	y (mm)	1400	1400	1400	1400	1400	1400
2.1	Service weight ⁽⁶⁾	kg	3362	3362	3560	3571	3745	3791
2.3	Axle loading, unladen front/rear ⁽⁵⁾	kg	2164 / 1198	2164 / 1198	2231 / 1329	2238 / 1333	2261 / 1484	2209 / 1501
2.4	Axle loading fork advanced, laden front/rear	kg	932 / 3830	932 / 3830	998 / 3961	1006 / 3965	1091 / 4054	1120 / 4071
2.5	Axle loading fork retracted, laden front/rear	kg	1893 / 2869	1893 / 2869	1959 / 3000	1966 / 3004	1917 / 3228	1947 / 3245
4.7	Height of overhead guard (cabin) ⁽⁴⁾	h ₆ (mm)	2231	2231	2231	2231	2231	2231
4.19	Overall length	l ₁ (mm)	2605	2605	2605	2605	2677	2677
4.20	Length to face of forks	l ₂ (mm)	1455	1455	1455	1455	1527	1527
4.28	Reach distance	l ₄ (mm)	513	513	513	513	441	441
4.34.1	Aisle width for pallets 1000mm x 1200mm crossways	A _{st} (mm)	2895	2895	2895	2895	2950	2950
4.34.2	Aisle width for pallets 800mm x 1200mm lengthwise	A _{st} (mm)	2955	2955	2955	2955	3021	3021
4.35	Turning radius	W _a (mm)	1787	1787	1787	1787	1787	1787
4.37	Length across wheel arms	l ₇ (mm)	1949	1949	1949	1949	1949	1949
6.3	Battery according to DIN 43531 / 35 / 36 A,B,C, no		C	C "Super"	C	C "Super"	C	C "Super"
6.4	Battery voltage/nominal capacity K ₅	(V) / (Ah)	48 / 420	48 / 465	48 / 560 ⁽²⁾	48 / 620 ⁽²⁾	48 / 700 ⁽³⁾	48 / 775 ⁽³⁾
6.5	Battery weight ⁽¹⁾	kg	750	750	939	950	1119	1165

MR16 Cold Store Cabin dimensions

1.8	Load distance, centre of drive axle to fork	x (mm)	380	380	380	380	308	308
1.9	Wheelbase	y (mm)	1450	1450	1450	1450	1450	1450
2.1	Service weight ⁽⁶⁾	kg	3412	3412	3610	3621	3796	3842
2.3	Axle loading, unladen front/rear ⁽⁵⁾	kg	2206 / 1206	2206 / 1206	2273 / 1337	2281 / 1340	2307 / 1489	2337 / 1505
2.4	Axle loading fork advanced, laden front/rear	kg	851 / 4162	851 / 4162	918 / 4292	925 / 4296	1014 / 4382	1043 / 4398
2.5	Axle loading fork retracted, laden front/rear	kg	1962 / 3051	1962 / 3051	2029 / 3181	2036 / 3185	1983 / 3413	2013 / 3429
4.7	Height of overhead guard (cabin) ⁽⁴⁾	h ₆ (mm)	2231	2231	2231	2231	2231	2231
4.19	Overall length	l ₁ (mm)	2605	2605	2605	2605	2677	2677
4.20	Length to face of forks	l ₂ (mm)	1455	1455	1455	1455	1527	1527
4.28	Reach distance	l ₄ (mm)	563	563	563	563	491	491
4.34.1	Aisle width for pallets 1000mm x 1200mm crossways	A _{st} (mm)	2905	2905	2905	2905	2959	2959
4.34.2	Aisle width for pallets 800mm x 1200mm lengthwise	A _{st} (mm)	2956	2956	2956	2956	3022	3022
4.35	Turning radius	W _a (mm)	1834	1834	1834	1834	1834	1834
4.37	Length across wheel arms	l ₇ (mm)	1999	1999	1999	1999	1999	1999
6.3	Battery according to DIN 43531 / 35 / 36 A,B,C, no		C	C "Super"	C	C "Super"	C	C "Super"
6.4	Battery voltage/nominal capacity K ₅	(V) / (Ah)	48 / 420	48 / 465	48 / 560 ⁽²⁾	48 / 620 ⁽²⁾	48 / 700 ⁽³⁾	48 / 775 ⁽³⁾
6.5	Battery weight ⁽¹⁾	kg	750	750	939	950	1119	1165

MR16N Cold Store Cabin dimensions

1.8	Load distance, centre of drive axle to fork	x (mm)	282	282	282	282	202	202
1.9	Wheelbase	y (mm)	1450	1450	1450	1450	1450	1450
2.1	Service weight ⁽⁶⁾	kg	3351	3351	3549	3557	3738	3754
2.3	Axle loading, unladen front/rear ⁽⁵⁾	kg	2162 / 1189	2162 / 1189	2147 / 1402	2152 / 1405	2155 / 1583	2165 / 1589
2.4	Axle loading fork advanced, laden front/rear	kg	809 / 4142	809 / 4142	872 / 4277	877 / 4280	957 / 4381	966 / 4387
2.5	Axle loading fork retracted, laden front/rear	kg	1920 / 3032	1920 / 3032	1806 / 3343	1811 / 3346	1714 / 3624	1724 / 3630
4.7	Height of overhead guard (cabin) ⁽⁴⁾	h ₆ (mm)	2231	2231	2231	2231	2231	2231
4.19	Overall length	l ₁ (mm)	2693	2693	2693	2693	2783	2783
4.20	Length to face of forks	l ₂ (mm)	1543	1543	1543	1543	1633	1633
4.28	Reach distance	l ₄ (mm)	475	475	475	475	385	385
4.34.1	Aisle width for pallets 1000mm x 1200mm crossways	A _{st} (mm)	2936	2936	2936	2936	3007	3007
4.34.2	Aisle width for pallets 800mm x 1200mm lengthwise	A _{st} (mm)	3002	3002	3002	3002	3085	3085
4.35	Turning radius	W _a (mm)	1800	1800	1800	1800	1800	1800
4.37	Length across wheel arms	l ₇ (mm)	1999	1999	1999	1999	1999	1999
6.3	Battery according to DIN 43531 / 35 / 36 A,B,C, no		B	B "Super"	B	B "Super"	B	B "Super"
6.4	Battery voltage/nominal capacity K ₅	(V) / (Ah)	48 / 420	48 / 465	48 / 560 ⁽²⁾	48 / 620 ⁽²⁾	48 / 700 ⁽³⁾	48 / 775 ⁽³⁾
6.5	Battery weight ⁽¹⁾	kg	750	750	939	950	1119	1135

MR16HD Cold Store Cabin dimensions

1.8	Load distance, centre of drive axle to fork	x (mm)	248	248	248	248	248
1.9	Wheelbase	y (mm)	1450	1450	1450	1450	1450
2.1	Service weight ⁽⁶⁾	kg	4288	4299	4474	4474	4520
2.3	Axle loading, unladen front/rear ⁽⁵⁾	kg	2561 / 1727	2568 / 1731	2626 / 1848	2626 / 1848	2655 / 1865
2.4	Axle loading fork advanced, laden front/rear	kg	978 / 4910	986 / 4913	1177 / 4897	1177 / 4897	1207 / 4913
2.5	Axle loading fork retracted, laden front/rear	kg	2267 / 3621	2275 / 3624	2302 / 3772	2302 / 3772	2332 / 3788
4.7	Height of overhead guard (cabin) ⁽⁴⁾	h ₆ (mm)	2231	2231	2231	2231	2231
4.19	Overall length	l ₁ (mm)	2722	2722	2722	2722	2722
4.20	Length to face of forks	l ₂ (mm)	1587	1587	1587	1587	1587
4.28	Reach distance	l ₄ (mm)	446	446	446	446	446
4.34.1	Aisle width for pallets 1000mm x 1200mm crossways	A _{st} (mm)	2996	2996	2996	2996	2996
4.34.2	Aisle width for pallets 800mm x 1200mm lengthwise	A _{st} (mm)	3067	3067	3067	3067	3067
4.35	Turning radius	W _a (mm)	1834	1834	1834	1834	1834
4.37	Length across wheel arms	l ₇ (mm)	1999	1999	1999	1999	1999
6.3	Battery according to DIN 43531 / 35 / 36 A,B,C, no		C	C "Super"	C	C "Super"	C "Super"
6.4	Battery voltage/nominal capacity K ₅	(V) / (Ah)	48 / 560 ⁽²⁾	48 / 620 ⁽²⁾	48 / 700 ⁽³⁾	48 / 700 ⁽³⁾	48 / 775 ⁽³⁾
6.5	Battery weight ⁽¹⁾	kg	939	950	1119	1119	1165

MR20 Cold Store Cabin dimensions

1.8	Load distance, centre of drive axle to fork	x (mm)	415	415	343	343
1.9	Wheelbase	y (mm)	1500	1500	1500	1500
2.1	Service weight ⁽⁶⁾	kg	3865	3876	4050	4096
2.3	Axle loading, unladen front/rear ⁽⁵⁾	kg	2460 / 1405	2467 / 1409	2495 / 1555	2525 / 1571
2.4	Axle loading fork advanced, laden front/rear	kg	870 / 4994	878 / 4998	969 / 5081	1000 / 5097
2.5	Axle loading fork retracted, laden front/rear	kg	2231 / 3634	2238 / 3637	2170 / 3880	2201 / 3896
4.7	Height of overhead guard (cabin) ⁽⁴⁾	h ₆ (mm)	2231	2231	2231	2231
4.19	Overall length	l ₁ (mm)	2605	2605	2677	2677
4.20	Length to face of forks	l ₂ (mm)	1470	1470	1542	1542
4.28	Reach distance	l ₄ (mm)	613	613	541	541
4.34.1	Aisle width for pallets 1000mm x 1200mm crossways	A _{st} (mm)	2922	2922	2974	2974
4.34.2	Aisle width for pallets 800mm x 1200mm lengthwise	A _{st} (mm)	2965	2965	3030	3030
4.35	Turning radius	W _a (mm)	1884	1884	1884	1884
4.37	Length across wheel arms	l ₇ (mm)	2049	2049	2049	2049
6.3	Battery according to DIN 43531 / 35 / 36 A,B,C, no		C	C "Super"	C	C "Super"
6.4	Battery voltage/nominal capacity K ₅	(V) / (Ah)	48 / 560 ⁽²⁾	48 / 620 ⁽²⁾	48 / 700 ⁽³⁾	48 / 775 ⁽³⁾
6.5	Battery weight ⁽¹⁾	kg	939	950	1119	1165

MR20HD Cold Store Cabin dimensions

1.8	Load distance, centre of drive axle to fork	x (mm)	293	293	266	266
1.9	Wheelbase	y (mm)	1500	1500	1500	1500
2.1	Service weight ⁽⁶⁾	kg	4675	4721	4867	4929
2.3	Axle loading, unladen front/rear ⁽⁵⁾	kg	2704 / 1971	2734 / 1987	2768 / 2099	2807 / 2122
2.4	Axle loading fork advanced, laden front/rear	kg	968 / 5707	998 / 5723	1176 / 5691	1215 / 5714
2.5	Axle loading fork retracted, laden front/rear	kg	2312 / 4362	2343 / 4378	2340 / 4527	2380 / 4549
4.7	Height of overhead guard (cabin) ⁽⁴⁾	h ₆ (mm)	2231	2231	2231	2231
4.19	Overall length	l ₁ (mm)	2727	2727	2754	2754
4.20	Length to face of forks	l ₂ (mm)	1592	1592	1619	1619
4.28	Reach distance	l ₄ (mm)	491	491	464	464
4.34.1	Aisle width for pallets 1000mm x 1200mm crossways	A _{st} (mm)	3011	3011	3032	3032
4.34.2	Aisle width for pallets 800mm x 1200mm lengthwise	A _{st} (mm)	3075	3075	3100	3100
4.35	Turning radius	W _a (mm)	1884	1884	1884	1884
4.37	Length across wheel arms	l ₇ (mm)	2039	2039	2049	2049
6.3	Battery according to DIN 43531 / 35 / 36 A,B,C, no		C	C "Super"	C	C "Super"
6.4	Battery voltage/nominal capacity K ₅	(V) / (Ah)	48 / 700 ⁽³⁾	48 / 775 ⁽³⁾	48 / 840	48 / 930
6.5	Battery weight ⁽¹⁾	kg	1119	1165	1306	1368

MR25 Cold Store Cabin dimensions

1.8	Load distance, centre of drive axle to fork	x (mm)	488	488	416	416
1.9	Wheelbase	y (mm)	1650	1650	1650	1650
2.1	Service weight ⁽⁶⁾	kg	4288	4334	4480	4480
2.3	Axle loading, unladen front/rear ⁽⁵⁾	kg	2709 / 1579	2741 / 1593	2754 / 1726	2754 / 1726
2.4	Axle loading fork advanced, laden front/rear	kg	962 / 5862	993 / 5841	1065 / 5916	1065 / 5916
2.5	Axle loading fork retracted, laden front/rear	kg	2560 / 4228	2591 / 4243	2495 / 4485	2495 / 4485
4.7	Height of overhead guard (cabin) ⁽⁴⁾	h ₆ (mm)	2231	2231	2231	2231
4.19	Overall length	l ₁ (mm)	2682	2682	2754	2754
4.20	Length to face of forks	l ₂ (mm)	1547	1547	1619	1619
4.28	Reach distance	l ₄ (mm)	686	686	614	614
4.34.1	Aisle width for pallets 1000mm x 1200mm crossways	A _{st} (mm)	3018	3018	3066	3066
4.34.2	Aisle width for pallets 800mm x 1200mm lengthwise	A _{st} (mm)	3046	3046	3109	3109
4.35	Turning radius	W _a (mm)	2029	2029	2029	2029
4.37	Length across wheel arms	l ₇ (mm)	2231	2231	2231	2231
6.3	Battery according to DIN 43531 / 35 / 36 A,B,C, no		C	C "Super"	C	C "Super"
6.4	Battery voltage/nominal capacity K ₅	(V) / (Ah)	48 / 700 ⁽³⁾	48 / 775 ⁽³⁾	48 / 840	48 / 930
6.5	Battery weight ⁽¹⁾	kg	1119	1165	1306	1368

Notes applicable to all tables on pages 10 and 11.

⁽¹⁾ These values may vary of +/- 5%.

⁽²⁾ Available Li-Ion battery 48V / 450Ah (895kg)

⁽³⁾ Available Li-Ion battery 48V / 450Ah (1067 / 1068kg);
Li-Ion battery 48V / 600Ah (1091kg).

⁽⁴⁾ With OGH Grid Protector +71mm;
With Work Lights to mast +152mm;
With Work Lights to front +175mm;
With Beacon +90mm.

⁽⁵⁾ Forks retracted.

⁽⁶⁾ Cold Store Cabin Standard with Glass Screens / Cold Store Cabin Standard with Polycarbonate Screens: 58kg less.

⁽⁷⁾ Cold Store Cabin Narrow with Glass Screens / Cold Store Cabin Narrow with Polycarbonate Screens: 60kg less.

All weights (2.1 to 2.5) are with lowest mast and standard forks.

All values are nominal values and they are subject to tolerances

For further information, please contact the manufacturer.

Yale products might be subject to change without notice.

Lift trucks illustrated may feature optional equipment.

Values may vary with alternative configurations.

MR series

Models: MR14, MR16, MR16N, MR16HD, MR20, MR20HD, MR25



The Yale MR Series Reach Truck features a three piece design for all models, the main differentiators being the wheelbase and truck width.

Overhead Guard

The one piece welded overhead guard gives a good visibility to all directions - two different pillar profiles give adequate stiffness strength and minimum impact on visibility. Optional drive-in overhead guards are available.

Operator compartment

The operator compartment structure is a one piece welded unit. The boxed bottom bottom is bolted to the frame having for rigidity and reduced operator vibrations.

The step with grip profile has a maximum depth of 130mm and low height of 371mm.

Frame

Completely welded base frame is available in 2 basic widths and 4 different lengths. The HD version has an increased width over the load arms.

Seats

Two different full-suspension seats with additional options are available, both adjustable for operator weight, fore/aft position and backrest angle.

Steering console

The steering console is adjustable for length and also 10° incline to provide the optimum position for the operator. To improve operators left arm ergonomics the steering column is slightly 3° angled anti clockwise.

Steering system

The steering is a fully fly-by-wire system. The steer wheel input and steer motor output are connected to the controller and managed by the VCM. Steer positioning sensors provide feedback of the actual steer position. The standard steering has a 180° steer angle, a 360° option is available and enabled by the VCM software, a third option allows switching from 180° to 360°. Speed reduction on cornering is automatic and can be adjusted.

Foot pedals

Low resistant foot pedals positioned on the inclined floor plate to improve the pedal operation ergonomics. The operator presence switch is slightly rotated to the mid line off the operator seat to improve operator left foot position. The thick one piece floor mat absorbs vibrations and noise out of the motor compartment.

Dash display

The display is integrated in the dashboard in front of the operator making easy to read and operate. An optional industry first premium touch screen display allows operators to be in full control of the truck at all times.



Vehicle Control Manager

The Vehicle Control Manager (VCM) is the central module of the truck and it is linked to the truck modules via Dual CAN bus system to increase reliability and truck dependability. With this proven technology used in the automobile sector point to point wiring is greatly reduced.

Hydraulic controls

The Hydraulic controls are integrated in ergonomic sliding armrest under driver's right hand. Standard controls are proven AccuTouch mini-levers module with separate horn and direction switches. A Joystick with integrated mini lever joystick for best ergonomic hydraulic operation is available as option.

Masts

A three stage full free lift mast incorporates unique Yale designed profiles that reduce the total mast

channel width. Lift cylinders are positioned to increase operator visibility, cross members are not in direct line of visibility for critical heights. The stiff and robust mast carriage is a welded construction made from lateral plates, several cross bars and base plate of to create an open boxed frame.

Motors

The drive motor remains in a fixed position to avoid flexing of the power cables.

Optimised acceleration and travel speed performance delivers high load handling and greater productivity. Easy access is provided by a swing-open motor compartment door.



The steering motor also uses AC technology and the gear on gear arrangement provides a positive mesh for precise steering control. On power-up the drive wheel is automatically centred. A removable plate allows access to the drive tyre/ gear reducer for servicing. The motor compartment including the hoist motor is ventilated.

Yale Europe Materials Handling

Centennial House, Frimley Business Park,
Frimley, Surrey GU16 7SG
United Kingdom



Tel: +44 (0) 1276 538500
Fax: +44 (0) 1276 538559

www.yale.com

Publication part no. 220990209 Rev.14 Printed in The Netherlands (0120HG) EN.
HYSTER-YALE UK LIMITED trading as Yale Europe Materials Handling.

Safety: This truck conforms to the current EU requirements.

Specification is subject to change without notice.

Yale, VERACITOR and  are registered trademarks. "PEOPLE, PRODUCTS, PRODUCTIVITY", PREMIER, Hi-Vis, and CSS are trademarks in the United States and certain other jurisdictions. MATERIALS HANDLING CENTRAL and MATERIAL HANDLING CENTRAL are Service Marks in the United States and certain other jurisdictions.  is a Registered Copyright.

©Yale Europe Materials Handling 2020. All rights reserved. Truck shown with optional equipment.
Country of Registration: England and Wales. Company Registration Number: 02636775

