



# GC-VX

## VERACITOR® CUSHION TIRE TRUCKS

13,500 · 15,500 lbs

### Yale® Veracitor® GC-VX Series

This series of trucks is designed to meet and exceed your materials handling application requirements. The Veracitor® truck is geared to minimize your cost of acquisition and the hourly cost of operation, yet provides uncompromised performance.

### Yale Veracitor® VX GM Vortec™ V-6

**Engines** feature a rigid cast iron block and main bearing caps. Nodular iron crankshaft is supported on four main bearings. Camshaft is cast iron. Hydraulic valve lifters are utilized to eliminate the need for manual adjustment. GM LPG engines include replaceable exhaust valve seats with stellite coated valves for superior durability. All engines are EPA emissions compliant and feature closed loop emissions regulation systems that continually monitor exhaust and adjust fuel/air mix as necessary. The GM engines also feature an electronic throttle for precise performance and control.

### Yale Veracitor® Optional Kubota 3.8L

**Diesel Engines** feature 4-valves per cylinder for improved horsepower and low end torque. The engines feature oil-cooled pistons which help maintain even cylinder temperatures. Built with forged steel crankshafts for durability, the Cummins engines are fully EPA emissions compliant, utilizing a mechanical fuel system controlled by the **Intellix VSM**.

### Fuel System

The standard LPG engine uses a vaporizer/regulator to convert the fuel from a liquid to a gas. The Engine Control Unit electronically regulates the fuel, air, and spark advance to provide the necessary torque. The engine control unit's inputs include manifold air pressure, manifold air temperature, engine coolant temperature, accelerator pedal position, throttle position, engine speed, cam signal, and oxygen sensor signal.

### Transmissions

There are two transmission selections available that will handle a wide variety of materials handling applications.

The standard electronic powershift transmission features two forward and two reverse speeds with electronic shift control, smooth hydraulic inching, neutral start switch, and anti-restart protection. A single pedal controls both inching and braking. Optional dual inch/brake pedals are available for operators who prefer this design. A 100 mesh suction and a

10 micron return line filtration protect the transmission from abrasive contaminants.

The Techtronix 332 includes all the features of the standard electronic powershift transmission. In addition, Auto Deceleration is accomplished through the controlled application of the clutch packs. Tire spin is reduced by precisely regulating engine speed during controlled power reversals (below 7 mph). Inching is controlled electronically. Techtronix 332 transmission features three speeds forward and two speeds in reverse for excellent gradeability and drawbar pull while allowing top travel speeds for maximum productivity.

**Cooling System** employs a 19" (diameter) blade pusher-type fan made of steel. A permanently lubricated water pump and a high capacity, cross-flow radiator ensure rapid heat dissipation. The sealed cooling system operates at a pressure of 15 psi and includes a coolant recovery tank for visual inspection of coolant level. The standard combi-cooler radiator features an externally mounted transmission oil cooler for increased heat transfer capability. Both the radiator and oil cooler are built with squarewave construction to reduce clogging from debris and are soft-mounted for excellent durability.

### Drive Axle

The drive axles are designed to withstand heavy loads and absorb shocks. The wheel hubs rotate on large tapered roller bearings. The drive shaft transmits rotational torque to the drive axle from the engine and transmission. Transmission torque is distributed through planetary gear reduction and an industrial hypoid ring gear and pinion differential assembly. The drive axle is a "self contained" assembly that is isolated from the transmission by the drive shaft and heavy duty rubber isolators. The axle shafts utilize a "rolled fillet" root spline design for increased resistance to torsion stress. A magnetic sump plug is used to collect any metal particles that are circulating in the axle oil, preventing component wear.

**Oil-cooled wet disc brakes** are standard and internal to the axle for better protection against the elements. These low pedal effort brakes require no adjustments and

### LPG Engine Specifications

Engine	GM Vortec™
Cylinders	V-6
Displacement	262 cu.in./4.3 liter
Torque	225 lb.ft. @ 2400 RPM
Horsepower	101 hp @ 2400 RPM
Air Filtration	Two Stage, Dry Type
Emission Control	Closed loop

### Diesel Engine Specifications

Engine	Kubota 3.8L
Cylinders	I-4
Camshaft	Overhead Valve
Displacement	230 cu.in./3.8 liter
Torque	227 lb.ft. @ 1400 RPM
Horsepower	74 hp @ 1400 RPM
Air Filtration	Two Stage, Dry Type
Emissions Certification	Tier 4 Final

very little maintenance, yet provide an extremely long service life.

The hydraulically boosted single circuit master cylinder has a sealed fluid reservoir and features a fluid level sensor which activates an indicator light located on the instrument panel. Independent, hand adjustable parking brake with push-button release has an audible alarm to indicate when the operator has left the truck without applying the parking brake.

*(continued on back)*





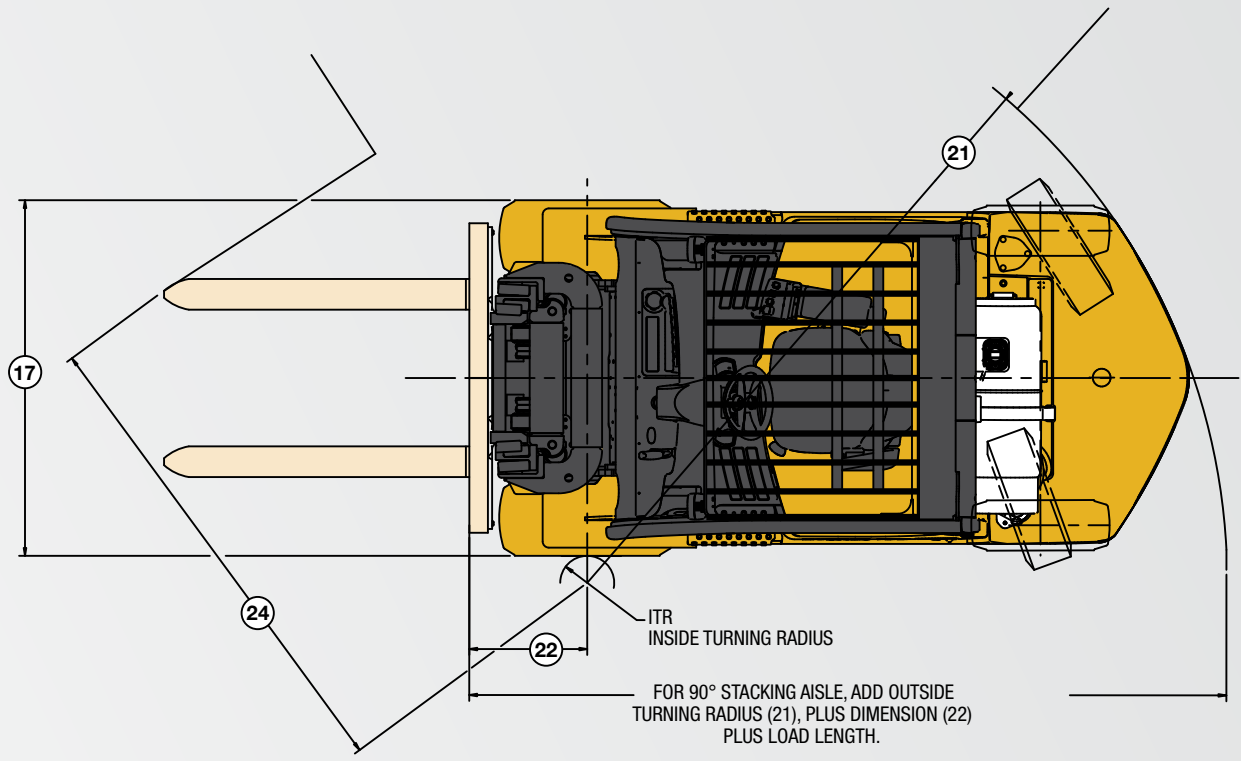

	Non Susp	Semi	Full	Swivel Full
Tall OHG (Std.)	42.0 (1068)	42.5 (1080)	41.8 (1062)	42.0 (1068)
Short OHG (Opt.)	39.4 (1001)	39.9 (1013)	N/A	N/A

TRUCK MODEL	C	D	E	T	X
	in (mm)	percent	percent	in (mm)	in (mm)
GC135-155VX	23.6 (600)	42%	46%	6.9 (177)	33.2 (844)

Dimensions with seat in depressed position.

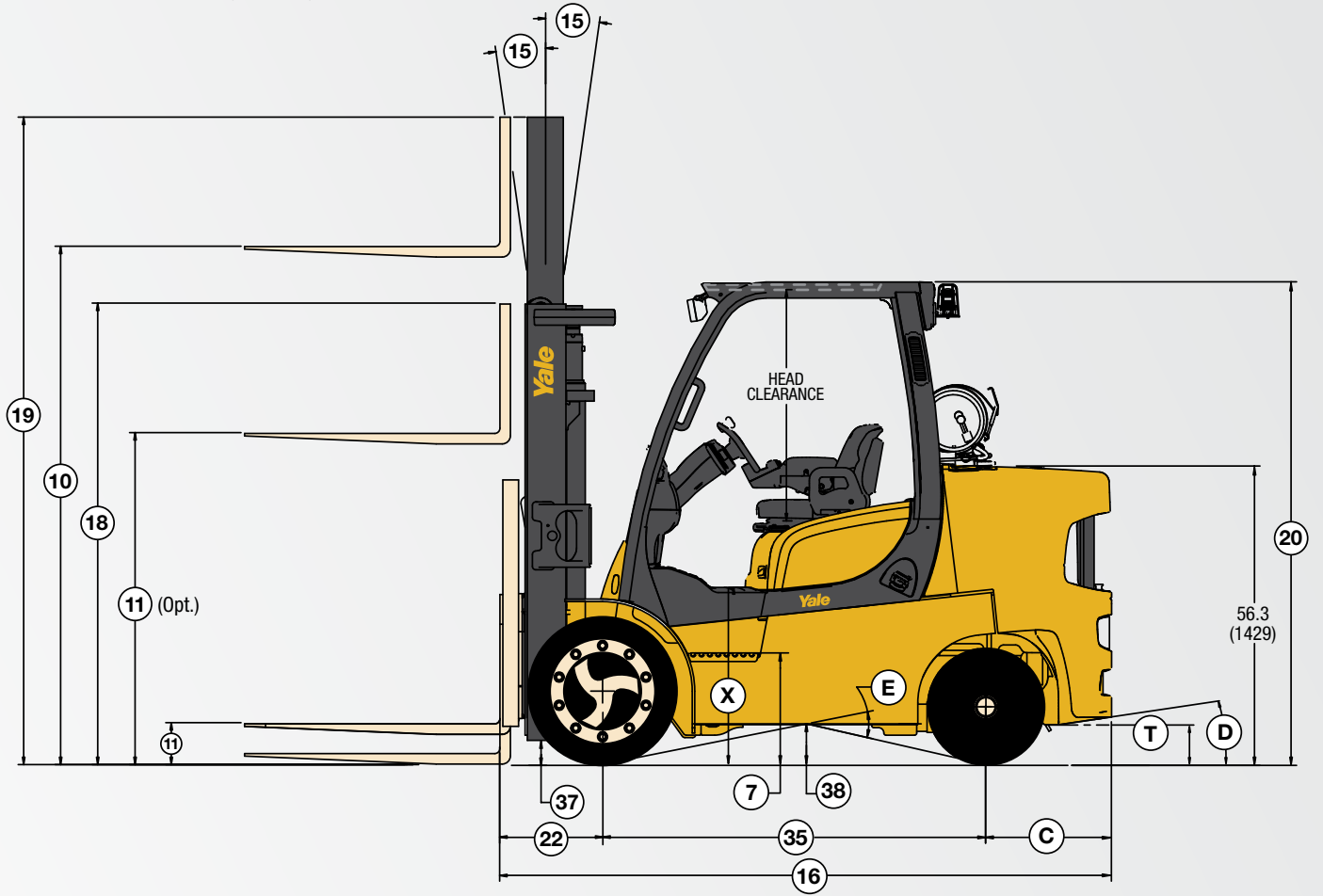

Circled dimensions correspond to the line numbers on the tabulated chart inside the spec sheet. Dimensions are in inches (millimeters).

GENERAL	1	Manufacturer	Yale		Yale	
	2	Model designation	GC135VX		GC135VX	
	2a	Brand Names for Transmissions	Standard Electronic Powershift		Techtronix 332	
	2b	Power Train - Engine Transmission	GM 4.3L	Kubota 3.8L Tier 4 Final	GM 4.3L	Kubota 3.8L Tier 4 Final
	3	Load capacity	13,500 (6,000)		13,500 (6,000)	
	4	Load center	24 (610)		24 (610)	
	5	Drive Power Type: Gas, Diesel, LPG	LPG	Diesel	LPG	Diesel
	6	Operation: Seated rider	Seated Rider		Seated Rider	
	7	Step Height	20.9 (531)		20.9 (531)	
DIMENSIONS	8	Tires	Cushion		Cushion	
	9	Number of wheels, front/rear (X = driven)	2X/2		2X/2	
	9a	Track width, front	44.6 (1133)		44.6 (1133)	
	9b	Track width, rear	46.9 (1192)		46.9 (1192)	
	10	Lift height (TOF)	133 (3400)		133 (3400)	
	11	Standard Free lift height	6 (160)		6 (160)	
	11a	Optional Free lift w/LBR (TOF)	50 (1295)		50 (1295)	
	11b	Optional Free lift w/o LBR (TOF)	56 (1425)		56 (1425)	
	12	Fork carriage width – Standard Carriage	48 (1219)		48 (1219)	
	13	Fork dimensions	6 X 2.5 X 48 (150 X 60 X 1219)		6 X 2.5 X 48 (150 X 60 X 1219)	
	13a	Fork Spacing – Std Carriage – Minimum Inside to inside edge	6.3 (160)		6.3 (160)	
	14	Fork Spacing – Std Carriage – Maximum outside to outside edge	43.7 (1109)		43.7 (1109)	
	15	Mast tilt, forward/back	6 F/10 B		6 F/10 B	
	16	Overall length (length to face of forks)	115.3 (2930)		115.3 (2930)	
	17	Overall width	56.6 (1438)		56.6 (1438)	
	18	Height of Standard mast, lowered	107 (2697)		107 (2697)	
	19	Height of mast, extended w/o load backrest	181 (4575)		181 (4575)	
	19a	Height of mast, extended w/load backrest	183 (4632)		183 (4632)	
	20	Height to top of Std. overhead guard (high)	91 (2302)		91 (2302)	
	20a	Height to top of overhead guard (low)	88 (2235)		88 (2235)	
	20b	Towing coupling height	15.3 (388)		15.3 (388)	
	21	Outer turning radius	101.8 (2585)		101.8 (2585)	
	21a	Inner turning radius	4.3 (108)		4.3 (108)	
	PERFORMANCE	22	Load distance (load face-ctr of wheel to face of forks-front overhang) 2-stg mast	19.6 (498)		19.6 (498)
22a		Load distance (load face-ctr of wheel to face of forks-front overhang) 3-stg mast	21.0 (534)		21.0 (534)	
23		Right angle stack (with pallet W=42in, L=48in)	169.4 (4302)		169.4 (4302)	
23a		Right angle stack (add length of load)	121.4 (3083)		121.4 (3083)	
24		90° intersecting aisle (with pallet W=42in, L=48in)	91.2 (2317)		91.2 (2317)	
25		Travel speed (RL/NL)	12.5/12.0 (20.1/19.4)	12.9/12.4 (20.7/20.0)	13.0/12.5 (20.8/20.1)	13.0/12.6 (20.9/20.2)
26		Lifting speed (2LFL) (RL/NL)	104/106 (.53/.54)	94/96 (.48/.49)	104/106 (.53/.54)	94/96 (.48/.49)
26a		Lifting speed (3FFL) (RL/NL)	100/102 (.51/.52)	93/93 (.47/.47)	100/102 (.51/.52)	93/93 (.47/.47)
27		Lowering speed (2LFL) (RL/NL)	114/104 (.58/.53)		114/104 (.58/.53)	
27a		Lowering speed (3FFL) (RL/NL)	104/81 (.53/.41)		104/81 (.53/.41)	
WT.	28	Maximum drawbar pull (RL/NL)	10548/4800 (4784/2177)	11104/4821 (5037/2187)	10000/4800 (4536/2177)	10000/4821 (4536/2187)
	28a	Drawbar pull @ 1.0 mph or 1.6 km/h (RL/NL)	8641/4800 (3919/2177)	8525/4821 (3867/2187)	10000/4800 (4536/2177)	10000/4821 (4536/2187)
	28b	Drawbar pull @ 3.0 mph or 4.8 km/h (RL/NL)	5479/4800 (2485/2177)	5044/4821 (2283/2187)	6601/4800 (2994/2177)	5145/4821 (2334/2187)
	29	Gradeability max (RL/NL)	33.3/24.8	35.0/24.8	31.5/24.8	
	29a	Gradeability @ 1.0 mph or 1.6 km/h (RL/NL)	26.8/24.8	26.3/24.8	31.5/24.8	
	29b	Gradeability @ 3.0 mph or 4.8 km/h (RL/NL)	16.6/24.8	15.2/24.8	20.2/24.8	15.5/24.8
WHEELS & TIRES	31	Unladen weight (w/std equipment: mast, carriage, forks, etc.)	19000 (8618)		20900 (9480)	
	32	Axle loading w/ load (w/std option configuration) (front/rear)	29439/3055 (13353/1386)		33055/3345 (14993/629)	
	32a	Axle loading w/o load (w/std option configuration) (front/rear)	7773/11221 (3526/5090)		8179/12720 (3710/5770)	
	33	Tire size – front	28 X 12 X 22		28 X 12 X 22	
	34	Tire size – rear	22 X 12 X 16		22 X 12 X 16	
	35	Wheelbase	72.0 (1830)		72.0 (1830)	
	37	Ground clearance under mast, RL	4.1 (104)		4.1 (104)	
TRANS. & POWER UNIT	38	Ground clearance at center of wheelbase	7.4 (188)		7.4 (188)	
	39	Brakes Service – Method of Control/Operation	Hydraulic/Foot		Hydraulic/Foot	
	40	Brakes Park – Method of Control/Operation	Mechanical/Hand		Mechanical/Hand	
	41	Battery Type	Maintenance Free		Maintenance Free	
	42	Battery Volts/Cold Cranking Amps	12V/475	12V/900	12V/475	12V/900
	43	Engine manufacturer/type	GM LPG	Kubota Turbo Diesel	GM LPG	Kubota Turbo Diesel
	44	Engine output, in accordance with ISO1585	101 (75) @ 2400 RPM	74 (55) @ 2200 RPM	101 (75) @ 2400 RPM	74 (55) @ 2200 RPM
	45	Torque	220 (300) @ 2400 RPM	227 (309) @ 1400 RPM	220 (300) @ 2400 RPM	227 (309) @ 1400 RPM
	46	Number of cylinders/displacement	V6/4302 (262)	4/3769 (230)	V6/4302 (262)	4/3769 (230)
	47	Gear change type	Electronically Controlled Powershift		Electronically Controlled Powershift	
47a	Transmission: Number of speeds forward/reverse	2F/2R		3F/2R		
48	Fuel Tank – Capacity (Gasoline- or Diesel-Powered Units Only)	18.5 (70)		18.5 (70)		
49	Working pressure for attachments	2250 (153)		2250 (153)		
50	Hydraulic Tank – capacity (drain & refill)	16.3 (61.8)		16.3 (61.8)		

RL = Rated Load, NL = No Load

GENERAL	1	Manufacturer		Yale		Yale		
	2	Model designation		GC155VX		GC155VX		
	2a	Brand Names for Transmissions		Standard Electronic Powershift		Techtronix 332		
	2b	Power Train - Engine Transmission		GM 4.3L	Kubota 3.8L Tier 4 Final	GM 4.3L	Kubota 3.8L Tier 4 Final	
	3	Load capacity	lbs (kg)	15,500 (7,000)		15,500 (7,000)		
	4	Load center	in (mm)	24 (610)		24 (610)		
	5	Drive Power Type: Gas, Diesel, LPG		LPG	Diesel	LPG	Diesel	
	6	Operation: Seated rider		Seated Rider		Seated Rider		
	7	Step Height	in (mm)	20.9 (531)		20.9 (531)		
	8	Tires		Cushion		Cushion		
DIMENSIONS	9	Number of wheels, front/rear (X = driven)		2X/2		2X/2		
	9a	Track width, front	in (mm)	44.6 (1133)		44.6 (1133)		
	9b	Track width, rear	in (mm)	46.9 (1192)		46.9 (1192)		
	10	Lift height (TOF)	in (mm)	133 (3400)		133 (3400)		
	11	Standard Free lift height	in (mm)	6 (160)		6 (160)		
	11a	Optional Free lift w/LBR (TOF)	in (mm)	50 (1295)		50 (1295)		
	11b	Optional Free lift w/o LBR (TOF)	in (mm)	56 (1425)		56 (1425)		
	12	Fork carriage width – Standard Carriage	in (mm)	48 (1219)		48 (1219)		
	13	Fork dimensions	in (mm)	6 X 2.5 X 48 (150 X 60 X 1219)		6 X 2.5 X 48 (150 X 60 X 1219)		
	13a	Fork Spacing – Std Carriage – Minimum Inside to inside edge	in (mm)	6 (160)		6 (160)		
	14	Fork Spacing – Std Carriage – Maximum outside to outside edge	in (mm)	43.7 (1109)		43.7 (1109)		
	15	Mast tilt, forward/back	degrees	6 F/10 B		6 F/10 B		
	16	Overall length (length to face of forks)	in (mm)	115.3 (2930)		115.3 (2930)		
	17	Overall width	in (mm)	56.6 (1438)		56.6 (1438)		
	18	Height of Standard mast, lowered	in (mm)	107 (2697)		107 (2697)		
	19	Height of mast, extended w/o load backrest	in (mm)	181 (4575)		181 (4575)		
	19a	Height of mast, extended w/load backrest	in (mm)	183 (4632)		183 (4632)		
	20	Height to top of Std. overhead guard (high)	in (mm)	91 (2302)		91 (2302)		
	20a	Height to top of overhead guard (low)	in (mm)	88 (2235)		88 (2235)		
	20b	Towing coupling height	in (mm)	15.3 (388)		15.3 (388)		
	21	Outer turning radius	in (mm)	101.8 (2585)		101.8 (2585)		
	21a	Inner turning radius	in (mm)	4.3 (108)		4.3 (108)		
	PERFORMANCE	22	Load distance (load face-ctr of wheel to face of forks-front overhang) 2-stg mast	in (mm)	19.6 (498)		19.6 (498)	
		22a	Load distance (load face-ctr of wheel to face of forks-front overhang) 3-stg mast	in (mm)	21.0 (534)		21.0 (534)	
23		Right angle stack (with pallet W=42in, L=48in)	in (mm)	169.4 (4302)		169.4 (4302)		
23a		Right angle stack (add length of load)	in (mm)	121.4 (3083)		121.4 (3083)		
24		90° intersecting aisle (with pallet W=42in, L=48in)	in (mm)	91.2 (2317)		91.2 (2317)		
25		Travel speed (RL/NL)	mph (km/hr)	12.5 / 12.0 (20.1 / 19.4)	12.9 / 12.4 (20.7 / 20.0)	13.0/12.5 (20.8/20.1)	13.0/12.6 (20.9/20.2)	
26		Lifting speed (2LFL) (RL/NL)	ft/min (m/sec)	104/106 (.53/.54)	89/96 (.45/.49)	104/106 (.53/.54)	89/96 (.45/.49)	
26a		Lifting speed (3FFL) (RL/NL)	ft/min (m/sec)	100/102 (.51/.52)	87/93 (.44/.47)	100/102 (.51/.52)	87/93 (.44/.47)	
27		Lowering speed (2LFL) (RL/NL)	ft/min (m/sec)	114/104 (.58/.53)		114/104 (.58/.53)		
27a		Lowering speed (3FFL) (RL/NL)	ft/min (m/sec)	108/81 (.55/.41)		108/81 (.55/.41)		
WT.	28	Maximum drawbar pull (RL/NL)	lbs (kg)	10479/5069 (4753/2299)	11035/5090 (5005/2309)	10000/5069 (4538/2299)	10000/5090 (4536/2309)	
	28a	Drawbar pull @ 1.0 mph or 1.6 km/h (RL/NL)	lbs (kg)	8573/5069 (3889/2299)	8456/5090 (3836/2309)	10000/5069 (4538/2299)	10000/5090 (4536/2309)	
	28b	Drawbar pull @ 3.0 mph or 4.8 km/h (RL/NL)	lbs (kg)	5411/5069 (2454/2299)	4975/5090 (2257/2309)	6533/5069 (2963/2299)	5076/5090 (2302/2309)	
	29	Gradeability max (RL/NL)	%	29.3/23.9	30.8/23.9	27.9/23.9		
	29a	Gradeability @ 1.0 mph or 1.6 km/h (RL/NL)	%	23.6/23.9	23.2/23.9	27.9/23.9		
	29b	Gradeability @ 3.0 mph or 4.8 km/h (RL/NL)	%	14.7/23.9	13.4/22.4	17.9/23.9	13.7/23.9	
	31	Unladen weight (w/std equipment: mast, carriage, forks, etc.)	lbs (kg)	20900 (9480)		20900 (9480)		
32	Axle loading w/ load (w/std option configuration) (front/rear)	lbs (kg)	33055/3345 (14993/629)		33055/3345 (14993/629)			
32a	Axle loading w/o load (w/std option configuration) (front/rear)	lbs (kg)	8179/12720 (3710/5770)		8179/12720 (3710/5770)			
WHEELS & TIRES	33	Tire size – front		28 X 12 X 22		28 X 12 X 22		
	34	Tire size – rear		22 X 12 X 16		22 X 12 X 16		
	35	Wheelbase	in (mm)	72.0 (1830)		72.0 (1830)		
	37	Ground clearance under mast, RL	in (mm)	4.1 (104)		4.1 (104)		
	38	Ground clearance at center of wheelbase	in (mm)	7.4 (188)		7.4 (188)		
	39	Brakes Service – Method of Control/Operation		Hydraulic/Foot		Hydraulic/Foot		
	40	Brakes Park – Method of Control/Operation		Mechanical/Hand		Mechanical/Hand		
TRANS. & POWER UNIT	41	Battery Type		Maintenance Free		Maintenance Free		
	42	Battery Volts/Cold Cranking Amps		12V/475	12V/900	12V/475	12V/900	
	43	Engine manufacturer/type		GM LPG	Kubota Turbo Diesel	GM LPG	Kubota Turbo Diesel	
	44	Engine output, in accordance with ISO1585	hp (KW)	101 (75) @ 2400 RPM	74 (55) @ 2200 RPM	101 (75) @ 2400 RPM	74 (55) @ 2200 RPM	
	45	Torque	ft-lb (N-m)	220 (300) @ 2400 RPM	227 (309) @ 1400 RPM	220 (300) @ 2400 RPM	227 (309) @ 1400 RPM	
	46	Number of cylinders/displacement	No/cc (ci)	V6/4302 (262)	4/3769 (230)	V6/4302 (262)	4/3769 (230)	
	47	Gear change type		Electronically Controlled Powershift		Electronically Controlled Powershift		
	47a	Transmission: Number of speeds forward/reverse		2F/2R		3F/2R		
	48	Fuel Tank – Capacity (Gasoline- or Diesel-Powered Units Only)	gal (liters)	18.5 (70)		18.5 (70)		
	49	Working pressure for attachments	psi (bar)	2250 (153)		2250 (153)		
50	Hydraulic Tank – capacity (drain & refill)	gal (liters)	16.3 (61.8)		16.3 (61.8)			

RL = Rated Load, NL = No Load

(continued from cover)

**Hydraulic Power Steering** (hydrostatic steering) provides responsive control and eliminates mechanical linkages for reduced surface shock and simplified maintenance. The steering wheel is 12 inches in diameter with a textured surface grip and spinner knob, and requires only four turns lock-to-lock. The center mounted steer cylinder is located within the confines of the steer axle for protection.

**Steer Axle** is constructed of cast steel and is rubber shock mounted to the frame for reduced wear and vibration, while allowing excellent stability and axle articulation. The steer axle system features tapered spindle bearings and non-adjustable tie rod end for durability.

**Chassis** designed by state-of-the-art finite element methods features inch-thick frame members and contains a rugged, unitized frame structure with a low step for simple entrance to the operator's compartment. Ergonomically designed overhead guard is bar type for excellent visibility and reduced noise.

**Operator's Compartment** features cowl-mounted hydraulic control levers positioned on the right side of the steering column. Optional Accutouch mini-lever, electro-hydraulic controls are integrated into the operator's right-side armrest allowing superior ergonomic actuation. Automotive-style pedal arrangement with a large, single inch/brake pedal is standard. Rubber floor mat reduces noise and vibration. The floorplate can be removed without tools for excellent service

access. Low step height and a convenient hand grip provide easy entry and exit to and from the truck.

**Intellix VSM** acts as a master truck controller, providing extensive monitoring and control of truck functions and systems. CANbus technology reduces wiring complexity and enables comprehensive communications between truck systems. The ergonomically positioned dash display transmits continual feedback to the operator and allows for communication of service codes. Comprehensive on-board diagnostics enable quick and easy troubleshooting. The electrical system features sealed connectors and Hall Effect sensors for superior dependability.

**Hydraulic System** incorporates a gear type pump with a cast iron body for quiet efficiency. The system is protected from overloads by a main relief valve for the lift circuit and a secondary relief valve for tilt and auxiliary functions. Oil is double filtered through a 100 mesh suction line strainer and 10 micron return line filter. The hydraulic tank is integrated into the frame. For Accutouch mini-lever, electro-hydraulic controls, an emergency lowering valve is provided to allow the load to be lowered in the event of power loss. O-ring face seal fittings are used in all high pressure hydraulic connections.

**Yale® Hi-Vis™ Masts** are available in 2 Stage LFL (Limited Free Lift) and 3 Stage FFL (Full Free Lift) models. Mast features flush-faced design with

geometrically matched load roller bearings which are canted to support front and side thrust. The mast front rail flange angle coupled with three degree mast rollers significantly reduce channel and roller wear. A non-metallic phenolic mast trunnion bushing with woven reinforcement offers high load carrying capability with outstanding durability.

### Options

- Kubota 3.8L Tier 4 Final diesel engine
- Powertrain protection system
- Premium monitoring package
- High air intake with precleaner
- Accumulator
- Keyless start (w/auxiliary key switch)
- LED brake and back-up lights
- Headlights and rear drive lights with halogen bulbs
- Traction speed limiter
- Swing-out, drop-down EZ-Tank Bracket
- Accutouch mini-lever electro-hydraulic control
- Return-to-set tilt
- Rear drive handle with horn button
- Swivel full-suspension seats
- High-visibility non-cinch seat belt with or without interlock
- Foot Directional Control pedal
- Operator password
- Mirrors - dual side view
- Alarm-reverse actuated 82-102 dB(A) - self-adjusting
- Amber strobe light - continuous activated
- Paper applications kit
- 4 function (2 aux) hydraulic control valve
- 6° forward / 6° backward tilt

GC135-155VX MAST DIMENSIONS								
Maximum Fork Height	Overall Lowered Height	Overall Extended Height		Free-Lift (TOF)		Tilt	Approx. Total Wt. w/Standard Equipment	
		w/Load Backrest	w/o Load Backrest	w/Load Backrest	w/o Load Backrest		GC135VX	GC155VX
in (mm)	in (mm)	in (mm)	in (mm)	in (mm)	in (mm)	Rwd/Fwd	lbs (kg)	lbs (kg)
<b>2-Stage Limited Free-Lift (LFL) Mast</b>								
94 (2400)	87 (2197)	143 (3632)	141 (3575)	6 (160)	6 (160)	10°/6°	18700 (8509)	20600 (9344)
133 (3400)	107 (2697)	183 (4632)	181 (4575)	6 (160)	6 (160)	10°/6°	19000 (8618)	20900 (9480)
173 (4400)	126 (3197)	222 (5632)	220 (5575)	6 (160)	6 (160)	10°/6°	19450 (8822)	21360 (9689)
<b>3-Stage Full Free-Lift (FFL) Mast</b>								
149 (3800)	88 (2227)	198 (5026)	193 (4896)	39 (995)	44 (1125)	6°/6°	19560 (8872)	21460 (9734)
185 (4700)	100 (2527)	234 (5926)	229 (5796)	50 (1295)	56 (1425)	6°/6°	19810 (8986)	21710 (9847)
220 (5600)	112 (2827)	269 (6826)	262 (6696)	62 (1595)	67 (1725)	6°/6°	20060 (9099)	21960 (9961)

Note: GC135-155VX use standard 28 x 12 x 22 drive tires @ 56.6 inch (1438 mm) overall width.



YALE MATERIALS HANDLING CORPORATION

P.O. Box 7367, Greenville, NC 27835-7367

www.yale.com

Yale is a Registered Trademark and is a Registered Copyright. ©Yale Materials Handling Corporation 2015. All Rights Reserved.

Manufactured in our own ISO 9001 and 14001 Registered Facilities

2266-1C 5/2015 All trucks shown with optional equipment.

Truck performance may be affected by the condition of the vehicle, how it is equipped and the application. Consult your Yale® Industrial Truck Dealer if any of the information shown is critical to your application. Specifications are subject to change without notice.

This truck meets all applicable mandatory requirements of ANSI B56.1 Safety Standard for Powered Industrial Trucks at the time of manufacture. Classified by Underwriters' Laboratories, Inc., as to fire and electric shock hazard only for Type E industrial trucks.

The Yale® products included in this document may be covered by US patent 6,684,148 and other patents pending.