



MSW 26-33UX(L)

SPEC SHEET

Pedestrian straddle
leg stacker

2,600-3,300 lbs.

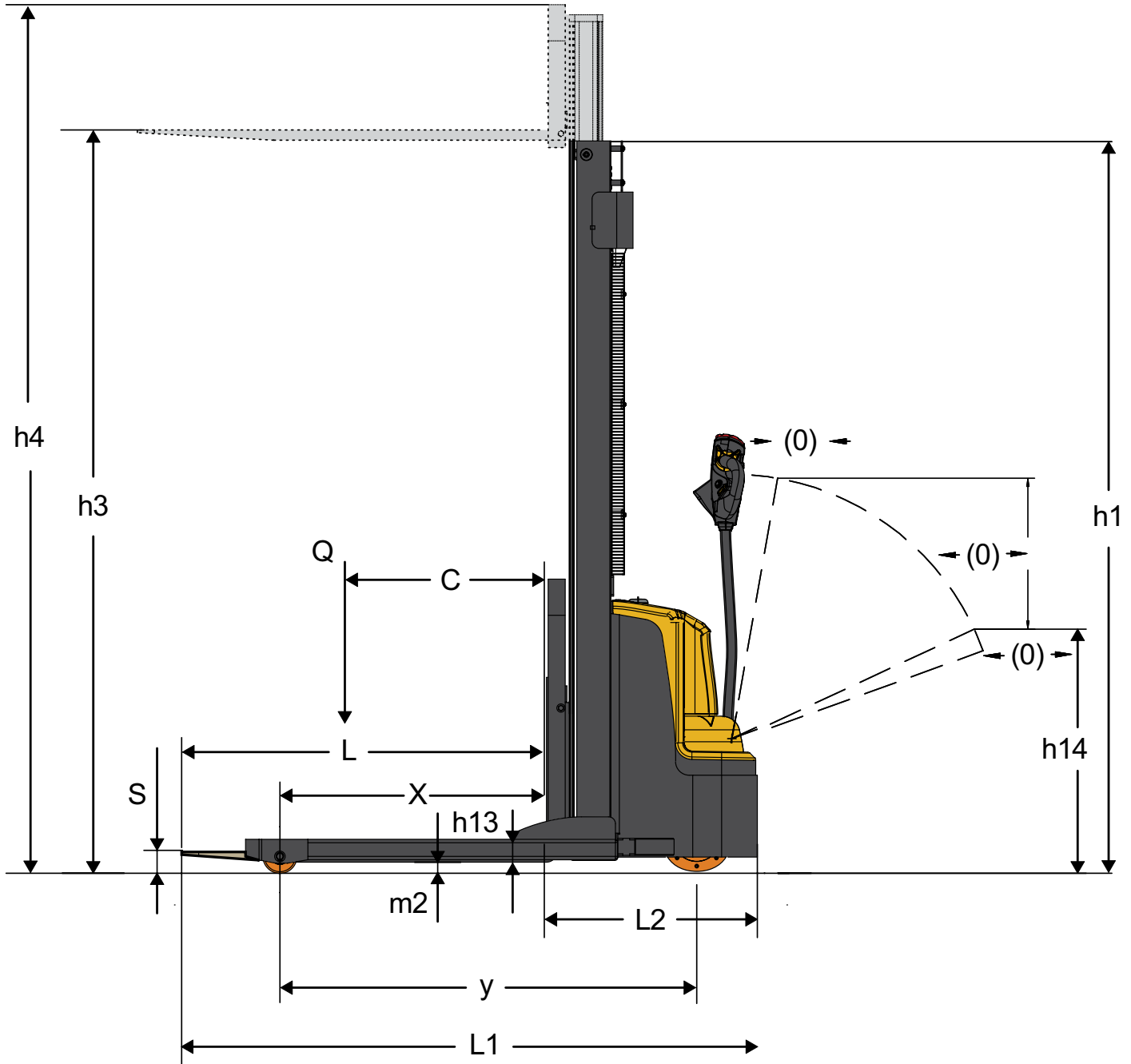

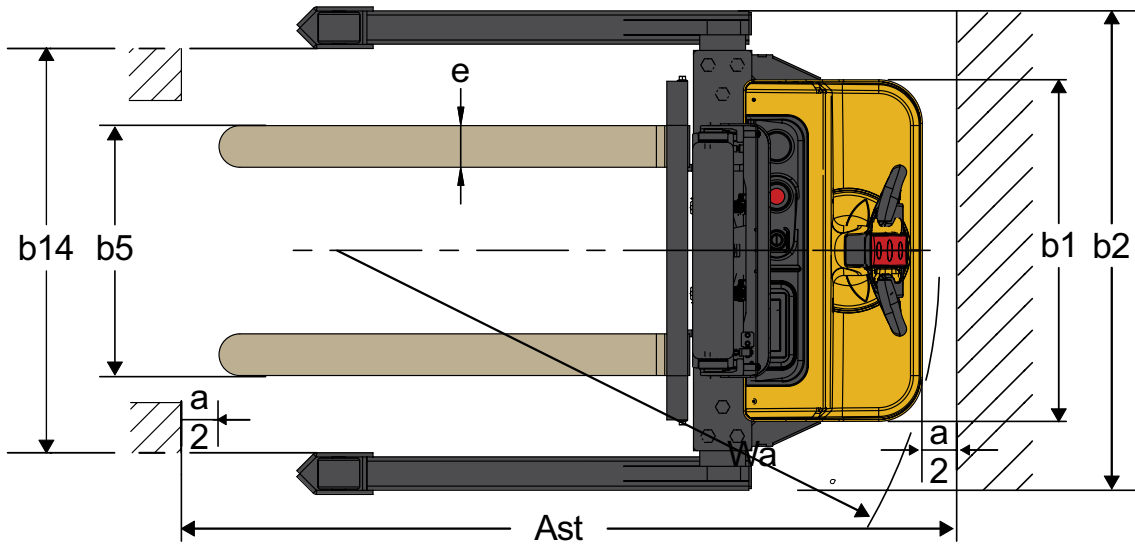

GENERAL SPECIFICATIONS - MSW26UX(L)

| | | | | | | | | | |
|-------------|------|---|---|-----------------------------------|--|---------------|---------------|---------------|--------------|
| GENERAL | 1-1 | Manufacturer | Yale | | | | | | |
| | 1-2 | Model designation | MSW26UX(L) | | | | | | |
| | 1-3 | Drive: electric (battery or mains), diesel, gasoline, LPG | Electric (battery) | | | | | | |
| | 1-4 | Operator type: hand, pedestrian, standing, seated, order-picker | Pedestrian | | | | | | |
| | 1-5 | Load capacity/rated load | Q | lb (kg) | 2600 (1200) | | | | |
| | 1-6 | Load center distance | c | in (mm) | 23.62 (600) | | | | |
| | 1-7 | Load distance, center of drive axle to fork | x | in (mm) | 29.61 (752) | | | | |
| | 1-8 | Wheelbase | y | in (mm) | 49 (1245) | | | | |
| WEIGHT | 2-1 | Service weight (without battery) | lb (kg) | 1276 (580) | 1327 (603) | 1393 (633) | 1463 (665) | 1542 (701) | |
| | 2-2 | Service weight (with 60Ah Li-battery) | lb (kg) | 1313 (597) | 1364 (620) | 1430 (650) | 1500 (682) | 1580 (718) | |
| | 2-3 | Service weight (with 100Ah Li-battery) | lb (kg) | 1329 (604) | 1379 (627) | 1445 (657) | 1516 (689) | 1595 (725) | |
| | 2-4 | Service weight (with battery 71Ah) | lb (kg) | 1378 (626.4) | 1429 (649.4) | 1495 (679.4) | 1565 (711.4) | 1644 (747.4) | |
| | 2-5 | Service weight (with battery 89Ah) | lb (kg) | 1390 (631.6) | 1440 (654.6) | 1506 (684.6) | 1577 (716.6) | 1656 (752.6) | |
| | 2-6 | Axle loading, laden front / rear (98.43 in lifting height) | lb (kg) | 1201 / 2803 (546 / 1274) | | | | | |
| | 2-7 | Axle loading, unladen front / rear (98.43 in lifting height) | lb (kg) | 1023 / 341 (465 / 155) | | | | | |
| TIRES | 3-1 | Wheels | Polyurethane | | | | | | |
| | 3-2 | Wheel size, front | Ø x width | in (mm) | 8.27x2.76 (210x70) | | | | |
| | 3-3 | Wheel size, rear | Ø x width | in (mm) | 3.94x2.52 (100x64) | | | | |
| | 3-4 | Wheels, number front/rear (x = driven wheels) | 1x +0 / 2 or 1x +2 / 2 (with balance wheel) | | | | | | |
| | 3-5 | Tread, front (equipped with balance wheel) | b10 | in (mm) | 26.2 (665.5) | | | | |
| | 3-6 | Tread, rear | b11 | in (mm) | 41.73 (1060) / 47.24 (1200) / 52.76 (1340) | | | | |
| DIMENSIONS | 4-1 | Lowered mast height | h1 | in (mm) | 58.27 (1480) | 68.11 (1730) | 77.95 (1980) | 83.86 (2130) | 87.8 (2230) |
| | 4-2 | Lift height | h3 | in (mm) | 78.74 (2000) | 98.43 (2500) | 118.11 (3000) | 129.92 (3300) | 137.8 (3500) |
| | 4-3 | Extended mast height | h4 | in (mm) | 110.24 (2800) | 129.92 (3300) | 149.61 (3800) | 161.42 (4100) | 169.3 (4300) |
| | 4-4 | Height of tiller in driving position, min./max. | h14 | in (mm) | 35.83 / 50 (910 / 1270) | | | | |
| | 4-5 | Height, lowered | h13 | in (mm) | 3.15 (80) | | | | |
| | 4-6 | Overall length (42 in fork length) | l1 | in (mm) | 67 (1705) (Standard 42" (1070) fork length) | | | | |
| | 4-7 | Length to face of forks | l2 | in (mm) | 25 (635) | | | | |
| | 4-8 | Overall width across chassis | b1 | in (mm) | 32.28 (820) | | | | |
| | 4-9 | Overall width across all/outer width straddle | b2 | in (mm) | 44.7 / 50.2 / 55.7 (1135/1275/1415) | | | | |
| | 4-10 | Inner width straddle | b14 | in (mm) | 38.2 / 43.7 / 49.2 (970/1110/1250) | | | | |
| | 4-11 | Fork dimensions | s/e/l | in (mm) | 1.58 x 3.94 x 42 (45.3 / 48) (40 X 100 X 1070 (1150/1220)) | | | | |
| | 4-12 | Width over forks (adjustable) | b5 | in (mm) | 7.87-31.3 (200-795) (Adjustable) | | | | |
| | 4-13 | Ground clearance, center of wheelbase | m2 | in (mm) | 1.58 (40) | | | | |
| | 4-14 | Aisle width for pallets 1000 × 1200 crossways | Ast | in (mm) | 90.16 (2290) | | | | |
| | 4-15 | Aisle width for pallets 800 × 1200 lengthways | Ast | in (mm) | 87.28 (2217) | | | | |
| | 4-16 | Turning radius | Wa | in (mm) | 56.6 (1455) | | | | |
| PERFORMANCE | 5-1 | Travel speed, with/without load | mph (km/h) | 2.49 / 2.8 (4 / 4.5) | | | | | |
| | 5-2 | Lift speed, without load | in/s (mm/s) | 0-9.06 (0-230) | | | | | |
| | 5-3 | Lift speed, with load | in/s (mm/s) | 0-4.84 (0-123) | | | | | |
| | 5-4 | Lowering speed, without load | in/s (mm/s) | 1.02-10.94 (26-278) | | | | | |
| | 5-5 | Lowering speed, with load | in/s (mm/s) | 1.1-6.46 (28-164) | | | | | |
| | 5-6 | Max. gradeability, with/without load | % | 5/10 | | | | | |
| | 5-7 | Service brake | Electromagnetic | | | | | | |
| ELECTRIC | 6-1 | Drive motor rating S2 60 min | kW | 0.75 | | | | | |
| | 6-2 | Lift motor rating at S3 15% | kW | 2.5 | | | | | |
| | 6-3 | Battery voltage/nominal capacity K5 (Li-battery) | V/Ah | 24V / 60Ah x 1 / 24V / 100Ah x 1 | | | | | |
| | 6-4 | Battery voltage/nominal capacity K5 (Lead-acid battery) | V/Ah | 12V / 71Ah x 2 / 12V / 89Ah x 2 | | | | | |
| | 6-5 | Battery weight +/- 5% (Li-battery) | lb (kg) | 14kg (60Ah) / 24kg (100Ah) | | | | | |
| | 6-6 | Battery weight +/- 5% (Lead-acid battery) | lb (kg) | 23.3 x 2 (71Ah) / 25.8 x 2 (89Ah) | | | | | |
| | 6-7 | Energy consumption according to EN 16796 | kWh | 0.42 | | | | | |
| ADDITION | 7-1 | Type of drive control | DC speed control | | | | | | |
| | 7-2 | Sound level at the driver's ear according to EN 12053 | dB(A) | <75 | | | | | |

Truck performance and dimensions are nominal and subject to tolerances.
Yale products and specifications are subject to change without notice.

GENERAL SPECIFICATIONS - MSW33UX(L)

| | | | | | | | | | |
|-------------|------|---|-----------|-------------|--|---------------|---------------|---------------|--------------|
| GENERAL | 1-1 | Manufacturer | | | Yale | | | | |
| | 1-2 | Model designation | | | MSW33UX(L) | | | | |
| | 1-3 | Drive: electric (battery or mains), diesel, gasoline, LPG | | | Electric (battery) | | | | |
| | 1-4 | Operator type: hand, pedestrian, standing, seated, order-picker | | | Pedestrian | | | | |
| | 1-5 | Load capacity/rated load | Q | lb (kg) | 3300 (1500) | | | | |
| | 1-6 | Load center distance | c | in (mm) | 23.62 (600) | | | | |
| | 1-7 | Load distance, center of drive axle to fork | x | in (mm) | 29.61 (752) | | | | |
| | 1-8 | Wheelbase | y | in (mm) | 49 (1245) | | | | |
| WEIGHT | 2-1 | Service weight (without battery) | | lb (kg) | 1280 (581.6) | 1330 (604.6) | 1396 (634.6) | 1467 (666.6) | 1546 (702.6) |
| | 2-2 | Service weight (with 60Ah Li-battery) | | lb (kg) | 1317 (598.6) | 1368 (621.6) | 1434 (651.6) | 1504 (683.6) | 1583 (719.6) |
| | 2-3 | Service weight (with 100Ah Li-battery) | | lb (kg) | 1332 (605.6) | 1383 (628.6) | 1449 (658.6) | 1519 (690.6) | 1599 (726.6) |
| | 2-4 | Service weight (with battery 71Ah) | | lb (kg) | 1382 (628) | 1432 (651) | 1498 (681) | 1569 (713) | 1648 (749) |
| | 2-5 | Service weight (with battery 89Ah) | | lb (kg) | 1393 (633.2) | 1444 (656.2) | 1510 (686.2) | 1580 (718.2) | 1659 (754.2) |
| | 2-6 | Axle loading, laden front / rear (98.43 in. lifting height) | | lb (kg) | 1401/3267 (636.6 / 1485) | | | | |
| | 2-7 | Axle loading, unladen front / rear (98.43 in. lifting height) | | lb (kg) | 1025/342 (466 / 155.6) | | | | |
| TIRES | 3-1 | Wheels | | | Polyurethane | | | | |
| | 3-2 | Wheel size, front | Ø x width | in (mm) | 8.27x2.76 (210x70) | | | | |
| | 3-3 | Wheel size, rear | Ø x width | in (mm) | 3.94x2.52 (100x64) | | | | |
| | 3-4 | Wheels, number front/rear (x = driven wheels) | | | 1x +0 / 2 or 1x +2 / 2 (with balance wheel) | | | | |
| | 3-5 | Tread, front (equipped with balance wheel) | b10 | in (mm) | 26.2 (665.5) | | | | |
| | 3-6 | Tread, rear | b11 | in (mm) | 41.73 (1060) / 47.24 (1200) / 52.76 (1340) | | | | |
| DIMENSIONS | 4-1 | Lowered mast height | h1 | in (mm) | 58.27 (1480) | 68.11 (1730) | 77.95 (1980) | 83.86 (2130) | 87.8 (2230) |
| | 4-2 | Lift height | h3 | in (mm) | 78.74 (2000) | 98.43 (2500) | 118.11 (3000) | 129.92 (3300) | 137.8 (3500) |
| | 4-3 | Extended mast height | h4 | in (mm) | 110.24 (2800) | 129.92 (3300) | 149.61 (3800) | 161.42 (4100) | 169.3 (4300) |
| | 4-4 | Height of tiller in driving position, min./max. | h14 | in (mm) | 35.83 / 50 (910 / 1270) | | | | |
| | 4-5 | Height, lowered | h13 | in (mm) | 3.15 (80) | | | | |
| | 4-6 | Overall length (42 in fork length) | l1 | in (mm) | 67 (1705) (Standard 42" (1070) fork length) | | | | |
| | 4-7 | Length to face of forks | l2 | in (mm) | 25 (635) | | | | |
| | 4-8 | Overall width across chassis | b1 | in (mm) | 32.28 (820) | | | | |
| | 4-9 | Overall width across all/outer width straddle | b2 | in (mm) | 44.7 / 50.2 / 55.7 (1135/1275/1415) | | | | |
| | 4-10 | Inner width straddle | b14 | in (mm) | 38.2 / 43.7 / 49.2 (970/1110/1250) | | | | |
| | 4-11 | Fork dimensions | s/e/l | in (mm) | 1.58 x 3.94 x 42 (45.3 / 48) (40 X 100 X 1070 (1150/1220)) | | | | |
| | 4-12 | Width over forks (adjustable) | b5 | in (mm) | 7.87-31.3 (200-795) (Adjustable) | | | | |
| | 4-13 | Ground clearance, center of wheelbase | m2 | in (mm) | 1.58 (40) | | | | |
| | 4-14 | Aisle width for pallets 1000 × 1200 crossways | Ast | in (mm) | 90.16 (2290) | | | | |
| | 4-15 | Aisle width for pallets 800 × 1200 lengthways | Ast | in (mm) | 87.28 (2217) | | | | |
| | 4-16 | Turning radius | Wa | in (mm) | 56.6 (1455) | | | | |
| PERFORMANCE | 5-1 | Travel speed, with/without load | | mph (km/h) | 2.49 / 2.8 (4 / 4.5) | | | | |
| | 5-2 | Lift speed, without load | | in/s (mm/s) | 0-7.28 (0-185) | | | | |
| | 5-3 | Lift speed, with load | | in/s (mm/s) | 0.4 (0-101) | | | | |
| | 5-4 | Lowering speed, without load | | in/s (mm/s) | 0.85-8.2 (21.7-208) | | | | |
| | 5-5 | Lowering speed, with load | | in/s (mm/s) | 1-5.4 (25.6-137) | | | | |
| | 5-6 | Max. gradeability, with/without load | | % | 5/10 | | | | |
| | 5-7 | Service brake | | | Electromagnetic | | | | |
| ELECTRIC | 6-1 | Drive motor rating S2 60 min | | kW | 0.75 | | | | |
| | 6-2 | Lift motor rating at S3 15% | | kW | 2.5 | | | | |
| | 6-3 | Battery voltage/nominal capacity K5 (Li-battery) | | V/Ah | 24V / 60Ah x 1 / 24V / 100Ah x 1 | | | | |
| | 6-4 | Battery voltage/nominal capacity K5 (Lead-acid battery) | | V/Ah | 12V / 71Ah x 2 / 12V / 89Ah x 2 | | | | |
| | 6-5 | Battery weight +/- 5% (Li-battery) | | lb (kg) | 14kg (60Ah) / 24kg (100Ah) | | | | |
| | 6-6 | Battery weight +/- 5% (Lead-acid battery) | | lb (kg) | 23.3 x 2 (71Ah) / 25.8 x 2 (89Ah) | | | | |
| | 6-7 | Energy consumption according to EN 16796 | | kWh | 0.42 | | | | |
| ADDITION | 7-1 | Type of drive control | | | DC speed control | | | | |
| | 7-2 | Sound level at the driver's ear according to EN 12053 | | dB(A) | <75 | | | | |

Truck performance and dimensions are nominal and subject to tolerances.
Yale products and specifications are subject to change without notice.

GENERAL SPECIFICATIONS - MSW33UX(L) (3" X 3")

| | | | | | | | | | |
|-------------|------|---|---|-----------------------------------|--|---------------|---------------|---------------|--------------|
| GENERAL | 1-1 | Manufacturer | Yale | | | | | | |
| | 1-2 | Model designation | MSW33UX(L) (3" x 3") | | | | | | |
| | 1-3 | Drive: electric (battery or mains), diesel, gasoline, LPG | Electric (battery) | | | | | | |
| | 1-4 | Operator type: hand, pedestrian, standing, seated, order-picker | Pedestrian | | | | | | |
| | 1-5 | Load capacity/rated load | Q | lb (kg) | 3300 (1500) | | | | |
| | 1-6 | Load center distance | c | in (mm) | 23.62 (600) | | | | |
| | 1-7 | Load distance, center of drive axle to fork | x | in (mm) | 29.61 (752) | | | | |
| | 1-8 | Wheelbase | y | in (mm) | 49 (1245) | | | | |
| WEIGHT | 2-1 | Service weight (without battery) | lb (kg) | 1280 (581.6) | 1330 (604.6) | 1396 (634.6) | 1467 (666.6) | 1546 (702.6) | |
| | 2-2 | Service weight (with 60Ah Li-battery) | lb (kg) | 1317 (598.6) | 1368 (621.6) | 1434 (651.6) | 1504 (683.6) | 1583 (719.6) | |
| | 2-3 | Service weight (with 100Ah Li-battery) | lb (kg) | 1332 (605.6) | 1383 (628.6) | 1449 (658.6) | 1519 (690.6) | 1599 (726.6) | |
| | 2-4 | Service weight (with battery 71Ah) | lb (kg) | 1382 (628) | 1432 (651) | 1498 (681) | 1569 (713) | 1648 (749) | |
| | 2-5 | Service weight (with battery 89Ah) | lb (kg) | 1393 (633.2) | 1444 (656.2) | 1510 (686.2) | 1580 (718.2) | 1659 (754.2) | |
| | 2-6 | Axle loading, laden front / rear (98.43 in. lifting height) | lb (kg) | 1401/3267 (636.6 / 1485) | | | | | |
| | 2-7 | Axle loading, unladen front / rear (98.43 in. lifting height) | lb (kg) | 1025/342 (466 / 155.6) | | | | | |
| TIRES | 3-1 | Wheels | Polyurethane | | | | | | |
| | 3-2 | Wheel size, front | Ø x width | in (mm) | 8.27x2.76 (210x70) | | | | |
| | 3-3 | Wheel size, rear | Ø x width | in (mm) | 4.53x1.93 (115x49) | | | | |
| | 3-4 | Wheels, number front/rear (x = driven wheels) | 1x +0 / 2 or 1x +2 / 4 (with balance wheel) | | | | | | |
| | 3-5 | Tread, front (equipped with balance wheel) | b10 | in (mm) | 26.2 (665.5) | | | | |
| | 3-6 | Tread, rear | b11 | in (mm) | 41.73 (1060) / 47.24 (1200) / 52.76 (1340) | | | | |
| DIMENSIONS | 4-1 | Lowered mast height | h1 | in (mm) | 58.27 (1480) | 68.11 (1730) | 77.95 (1980) | 83.86 (2130) | 87.8 (2230) |
| | 4-2 | Lift height | h3 | in (mm) | 78.74 (2000) | 98.43 (2500) | 118.11 (3000) | 129.92 (3300) | 137.8 (3500) |
| | 4-3 | Extended mast height | h4 | in (mm) | 110.24 (2800) | 129.92 (3300) | 149.61 (3800) | 161.42 (4100) | 169.3 (4300) |
| | 4-4 | Height of tiller in driving position, min./max. | h14 | in (mm) | 35.83 / 50 (910 / 1270) | | | | |
| | 4-5 | Height, lowered | h13 | in (mm) | 3.15 (80) | | | | |
| | 4-6 | Overall length (42 in fork length) | l1 | in (mm) | 67 (1705) (Standard 42" (1070) fork length) | | | | |
| | 4-7 | Length to face of forks | l2 | in (mm) | 25 (635) | | | | |
| | 4-8 | Overall width across chassis | b1 | in (mm) | 32.28 (820) | | | | |
| | 4-9 | Overall width across all/outer width straddle | b2 | in (mm) | 44.7 / 50.2 / 55.7 (1135/1275/1415) | | | | |
| | 4-10 | Inner width straddle | b14 | in (mm) | 38.8 / 44.3 / 49.8 (985/1125/1265) | | | | |
| | 4-11 | Fork dimensions | s/e/l | in (mm) | 1.58 x 3.94 x 42 (45.3 / 48) (40 X 100 X 1070 (1150/1220)) | | | | |
| | 4-12 | Width over forks (adjustable) | b5 | in (mm) | 7.87-31.3 (200-795) (Adjustable) | | | | |
| | 4-13 | Ground clearance, center of wheelbase | m2 | in (mm) | 1.58 (40) | | | | |
| | 4-14 | Aisle width for pallets 1000 x 1200 crossways | Ast | in (mm) | 90.16 (2290) | | | | |
| | 4-15 | Aisle width for pallets 800 x 1200 lengthways | Ast | in (mm) | 87.28 (2217) | | | | |
| | 4-16 | Turning radius | Wa | in (mm) | 56.6 (1455) | | | | |
| PERFORMANCE | 5-1 | Travel speed, with/without load | mph (km/h) | 2.49 / 2.8 (4 / 4.5) | | | | | |
| | 5-2 | Lift speed, without load | in/s (mm/s) | 0-7.28 (0-185) | | | | | |
| | 5-3 | Lift speed, with load | in/s (mm/s) | 0.4 (0-101) | | | | | |
| | 5-4 | Lowering speed, without load | in/s (mm/s) | 0.85-8.2 (21.7-208) | | | | | |
| | 5-5 | Lowering speed, with load | in/s (mm/s) | 1-5.4 (25.6-137) | | | | | |
| | 5-6 | Max. gradeability, with/without load | % | 5/10 | | | | | |
| | 5-7 | Service brake | Electromagnetic | | | | | | |
| ELECTRIC | 6-1 | Drive motor rating S2 60 min | kW | 0.75 | | | | | |
| | 6-2 | Lift motor rating at S3 15% | kW | 2.5 | | | | | |
| | 6-3 | Battery voltage/nominal capacity K5 (Li-battery) | V/Ah | 24V / 60Ah x 1 / 24V / 100Ah x 1 | | | | | |
| | 6-4 | Battery voltage/nominal capacity K5 (Lead-acid battery) | V/Ah | 12V / 71Ah x 2 / 12V / 89Ah x 2 | | | | | |
| | 6-5 | Battery weight +/- 5% (Li-battery) | lb (kg) | 14kg (60Ah) / 24kg (100Ah) | | | | | |
| | 6-6 | Battery weight +/- 5% (Lead-acid battery) | lb (kg) | 23.3 x 2 (71Ah) / 25.8 x 2 (89Ah) | | | | | |
| | 6-7 | Energy consumption according to EN 16796 | kWh | 0.42 | | | | | |
| ADDITION | 7-1 | Type of drive control | DC speed control | | | | | | |
| | 7-2 | Sound level at the driver's ear according to EN 12053 | dB(A) | <75 | | | | | |

Truck performance and dimensions are nominal and subject to tolerances.
Yale products and specifications are subject to change without notice.

FEATURES LIST

| PERFORMANCE | STD | OPT | ENERGY SYSTEM | STD | OPT |
|---|------------|------------|---|------------|------------|
| 24V system with brush motor | ● | | 24V/60Ah lithium-ion battery (UL) | ● | |
| Mechanical steering | ● | | On-board charger 24V/30A 100~240V UL (for lithium-ion battery) | ● | |
| Proportional speed on lifting/lowering | ● | | On-board charger plug (American Std) type B | ● | |
| Standard environmental construction (0-45°C;) | ● | | 24V/71Ah maintenance free lead-acid battery LEOCH (CE & UL) | | ● |
| DRIVE | STD | OPT | 24V/89Ah maintenance free lead-acid battery LEOCH (CE & UL) | | ● |
| 3.9" x 2.5" single Polyurethane load wheel (REACH) | ● | | 24V/100Ah lithium-ion battery (UL) | | ● |
| 3.9" x 1.9" single Polyurethane load wheel (REACH) for straddle leg size 3" x 3" | | ● | 1 extra battery | | ● |
| 8.3" x 3" Polyurethane (REACH) drive wheel | ● | | On-board charger 24V/10A 100~240V TL POWER (for lead-acid battery) non-CE | | ● |
| 3" x 1.2" double balance wheel | | ● | On-board charger 24V/15A 100~240V UL (For lead-acid battery) | | ● |
| LIFT | STD | OPT | On-board charger plug (Japanese Std) type A | | ● |
| 2 Stage No Free Lift - 69.7"/98.4" | ● | | SUPPLEMENTAL | STD | OPT |
| 2 Stage No Free Lift - 59.8"/78.7" | | ● | 12 Months / No Hour Limit Full Truck Warranty, 36 Months / 6,000 Hours Powertrain Warranty, Lifetime Frame Warranty; please see full Warranty Statement for additional details. | ● | |
| 2 Stage No Free Lift - 79.5"/118.1" | | ● | Operating manual | ● | |
| 2 Stage No Free Lift - 85"/130" | | ● | Parts manual | | ● |
| 2 Stage No Free Lift - 89"/138" | | ● | | | |
| HANDLING | STD | OPT | | | |
| 42.1" Long x 7.9-31.5" forks | ● | | | | |
| 45.3" Long x 7.9-31.5" forks | | ● | | | |
| 2.4" High x 3.5" Wide straddle leg | ● | | | | |
| 3" High x 3" Wide straddle leg | | ● | | | |
| OPERATION | STD | OPT | | | |
| Key switch | ● | | | | |
| Keypad with password protection non-CE | | ● | | | |
| Remote key: function for remote control lift/lower; 5 traveling speed setting, horn; (non-CE, non-UL) | | ● | | | |
| MDI Display - multi-function LCD screen display shows working status, hourmeter, BDI, error code | ● | | | | |
| Two side proportional control knob | ● | | | | |
| VISIBILITY | STD | OPT | | | |
| Metal wiremesh | ● | | | | |
| Lexan shield | | ● | | | |



About Yale

Yale Lift Truck Technologies leverages over a century of material handling experience and substantial investment in innovation to bring the most advanced technology-driven lift truck solutions to market. The company offers a full line of award-winning lift trucks, including reach trucks, order pickers, turret trucks, pallet jacks and trucks, pallet stackers, tow tractors and counterbalanced forklifts, as well as powerful operator assist solutions, proven automation and a wide range of power sources to help customers adapt to today's demanding supply chain. Yale and its independent dealer network support these solutions with comprehensive after-sales service, parts, financing and training.

MATERIALS HANDLING FOR:

Third-party logistics (3PL)

Auto parts distribution

Beverage

Cold & frozen foods

Food distribution

Food processing

Furniture & furnishings

Government

Health & pharma

Home centers & durables

Retail & e-commerce

Yale Lift Truck Technologies
P.O. Box 7367
Greenville, NC 27835-7367
U.S.A.

yale.com

© 2026 Hyster-Yale Materials Handling, Inc., all rights reserved. YALE and  are trademarks of Hyster-Yale Materials Handling, Inc.

Trucks may be shown with optional equipment and/or features not available in all regions. Truck performance may be affected by the condition of the vehicle, how it is equipped and the application. Specifications are subject to change without notice. Consult your Yale® Dealer if any of the information shown is critical to your application.

CERTIFICATION: Yale lift trucks meet the design and construction requirements of B56.1-1969, per OSHA Section 1910.178(a)(2), and also comply with the B56.1 revision in effect at time of manufacture. Classified by Underwriters' Laboratories, Inc.