



MRO 16-20

SPEC SHEET

Outdoor moving mast
reach truck

3,500-4,500 lbs.

WITHOUT CABIN

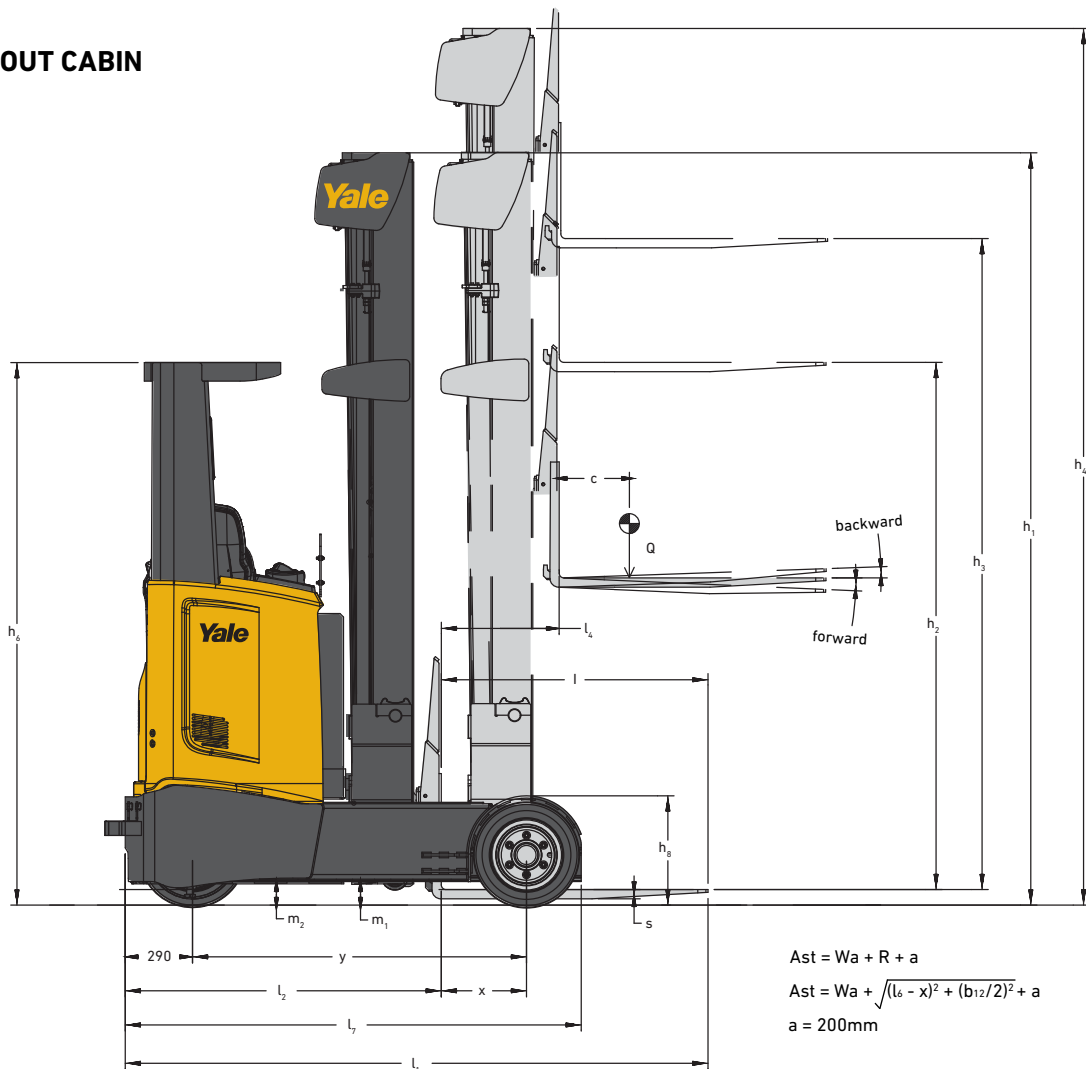

$$Ast = Wa + R + a$$

$$Ast = Wa + \sqrt{(l_6 - x)^2 + (b_{12}/2)^2} + a$$

$$a = 200\text{mm}$$

a = Clearance = 8"
 L6 = Load length
 b12 = Load width

$$AST = Wa + R + a$$

AST = Right Angle Stack

$$R = \sqrt{(l_6 - x)^2 + (b_{12}/2)^2}$$

B1 = overall width (operator side)
 B2 = overall width (mast side)
 B4 = width inside straddle

Dimensions in the specification chart are in inches (millimeters).

All AST dims provided include 8" of total clearance

TRUCK DIMENSIONS

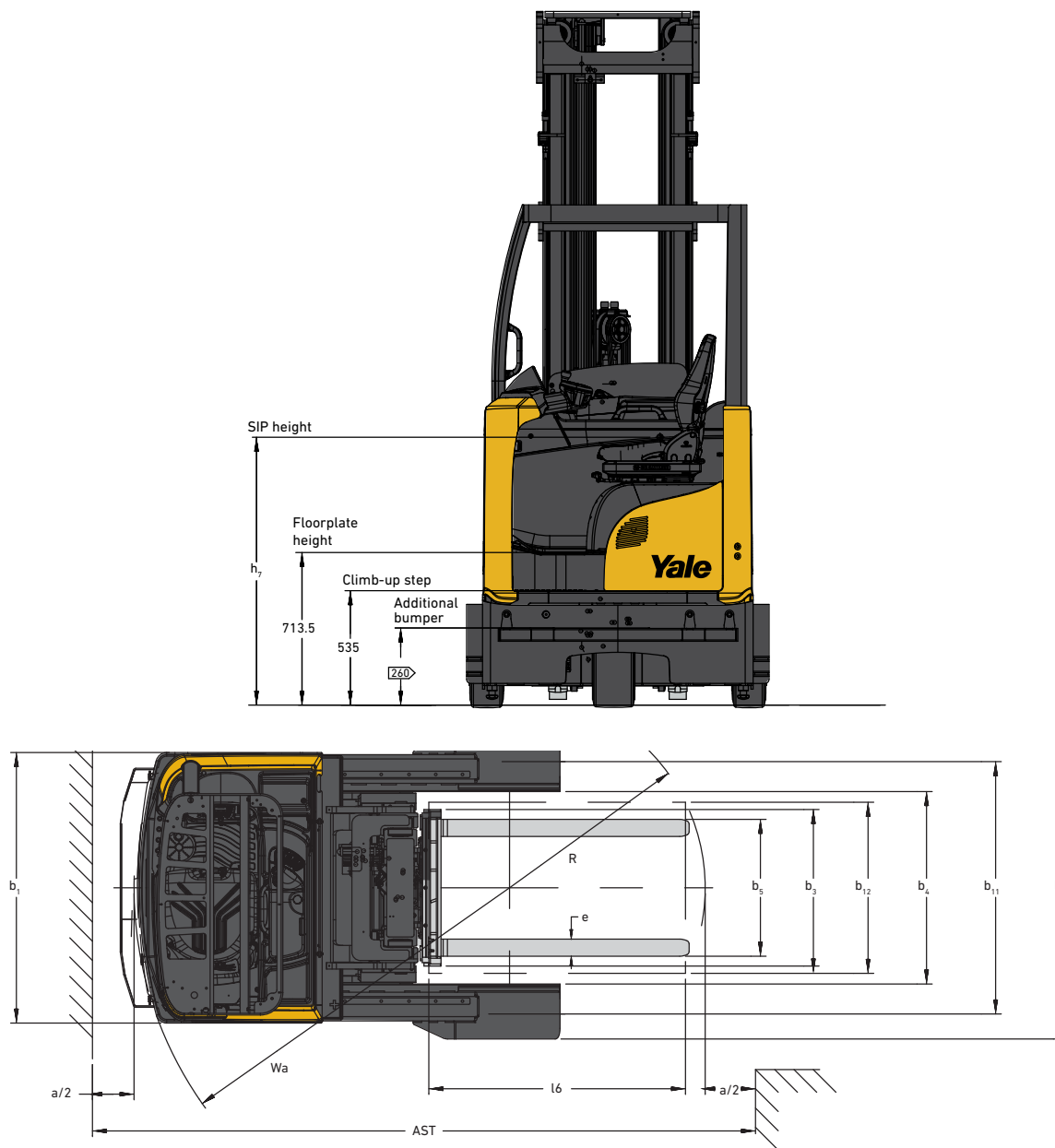

Circled dimensions correspond to the line numbers on the tabulated chart inside the spec sheet. Dimensions are in inches (millimeters).

All AST dims provided include 8" of total clearance

MRO16A GENERAL SPECIFICATIONS

					Yale	
GENERAL	1.1	Manufacturer (abbreviation)			MRO16A	MRO16A w/ cab
	1.2	Manufacturer's type designation			Electric (battery)	Electric (battery)
	1.3	Drive: electric, diesel, gasoline, LPG			Seated	Seated
	1.4	Operator type			3500 (1.6)	3500 (1.6)
	1.5	Rated capacity / rated load	lb (kg)	Q	24 (600)	24 (600)
	1.6	Load center distance	in (mm)	c	14.33 (364)	12.09 (307)
	1.8	Load distance, center of drive axle to fork	in (mm)	x	56.69 (1440)	56.69 (1440)
	1.9	Wheelbase	in (mm)	y	8437 (3827)	8755 (3971) ⁽²¹⁾
	WEIGHT	2.1	Service weight	lb (kg)		4896 / 3540 (2221 / 1606)
2.3		Axle loading, NL front / rear ⁽⁵⁾	lb (kg)		1505 / 10458 (683 / 4744)	1772 / 10507 (804 / 4766) ⁽²¹⁾
2.4		Axle loading fork advanced, RL front / rear	lb (kg)		4332 / 7632 (1965 / 3462)	4339 / 7943 (1968 / 3603) ⁽²¹⁾
2.5		Axle loading fork retracted, RL front / rear	lb (kg)			
2.5		Axle loading fork retracted, RL front / rear	lb (kg)			
TIRES	3.1	Tires, front / rear (SE=Pneumatic-Solid Shaped)			SE/SE	SE/SE
	3.2	Tire size, front			200 / 50-10	200 / 50-10
	3.3	Tire size, rear			180 / 60-10	180 / 60-10
	3.5	Wheels, number front / rear (x = driven wheels)			1x/2	1x/2
	3.7	Tread, rear	in (mm)	b ₁₁	48.25 (1225.5)	48.25 (1225.5)
	4.1	Tilt of mast / fork carriage, forward / backward (α / β)	degrees	f / b	2 / 4	2 / 4
	4.2	Height of mast, lowered	in (mm)	h ₁		
DIMENSIONS	4.3	Free lift	in (mm)	h ₂	See mast tables	
	4.4	Lift	in (mm)	h ₃		
	4.5	Height, mast extended ⁽¹⁾	in (mm)	h ₄		
	4.7	Height of overhead guard (cabin) ^{(2) (9) (11)}	in (mm)	h ₆		
	4.8	Seat height relating to SIP	in (mm)	h ₇	50.94 (1294)	50.94 (1294)
	4.10	Height of wheel arms	in (mm)	h ₈	18.54 (471)	18.54 (471)
	4.19	Overall length ⁽³⁾	in (mm)	l ₁	99.06 (2516)	101.3 (2573)
	4.20	Length to face of forks ⁽³⁾	in (mm)	l ₂	53.78 (1366)	56.02 (1423)
	4.21	Overall width	in (mm)	b ₁ / b ₂	49.80 / 55.67 (1265 / 1414)	49.80 / 55.67 (1265 / 1414)
	4.22	Fork dimensions DIN ISO 2331	in (mm)	s / e / l	1.4 / 4.7 / 45.3 (35 / 120 / 1150)	1.4 / 4.7 / 45.3 (35 / 120 / 1150)
	4.23	Fork carriage ISO 2328, class / type A, B			2A	2A
	4.24	Fork carriage width	in (mm)	b ₃	27.56 (700)	27.56 (700)
	4.25	Forks spread, min / max ⁽⁸⁾	in (mm)	b ₅	10.24 / 26.77 (260/680)	10.24 / 26.77 (260/680)
	4.26	Distance between wheel arms / loading surfaces	in (mm)	b ₄	35.43 (900)	35.43 (900)
	4.28	Reach distance	in (mm)	l ₄	24.02 (610)	21.77 (553)
	4.31	Ground clearance, RL, below mast	in (mm)	m ₁	3.60 (91.5)	3.60 (91.5)
	4.32	Ground clearance, center of wheelbase	in (mm)	m ₂	3.60 (91.5)	3.60 (91.5)
	4.34.1	Aisle width for pallets 1000mm × 1200mm crossways (l ₆ × b ₁₂)	in (mm)	Ast	111.42 (2830) ⁽¹⁷⁾	113.07 (2872) ⁽¹⁹⁾
	4.34.2	Aisle width for pallets 800mm × 1200mm lengthwise (b ₁₂ × l ₆)	in (mm)	Ast	113.46 (2882) ⁽¹⁸⁾	115.51 (2934) ⁽²⁰⁾
	4.34.3	Aisle width for pallets 40" × 48" lengthwise (b ₁₂ × l ₆)	in (mm)	Ast	116.15 (2950) ⁽²²⁾	118.10 (3000) ⁽¹⁴⁾
	4.34.4	Aisle width for pallets 48" × 48" (b ₁₂ × l ₆)	in (mm)	Ast	118.34 (3006) ⁽²³⁾	120.18 (3053) ⁽¹⁵⁾
4.34.5	Aisle width for pallets 48" × 40" crossways (b ₁₂ × l ₆)	in (mm)	Ast	112.15 (2849) ⁽²⁴⁾	113.80 (2875) ⁽¹⁶⁾	
4.35	Turning radius ⁽⁹⁾	in (mm)	W _a	69.13 (1756)	69.13 (1756)	
4.37	Length across wheel arms	in (mm)	l ₇	77.40 (1966)	77.40 (1966)	
4.42	Step height (from ground to running board)	in (mm)		28.11 (714)	28.11 (714)	
4.43	Step height (between intermediate steps and floor)	in (mm)		21.06 (535)	21.06 (535)	
PERFORMANCE	5.1	Travel speed, RL / NL	mph (km/h)		7.15 / 7.77 (11.5 / 12.5)	7.15 / 7.77 (11.5 / 12.5)
	5.1.1	Travel speed, RL / NL, backwards	mph (km/h)		7.15 / 7.77 (11.5 / 12.5)	7.15 / 7.77 (11.5 / 12.5)
	5.2	Lift speed, RL / NL	ft/min (m/s)		82.7 / 143.7 (0.42 / 0.73)	82.7 / 143.7 (0.42 / 0.73)
	5.3	Lowering speed, RL / NL	ft/min (m/s)		108.3 (0.55)	108.3 (0.55)
	5.4	Reaching speed, RL / NL	ft/min (m/s)		33.5 / 33.5 (0.17 / 0.17)	33.5 / 33.5 (0.17 / 0.17)
	5.7	Gradeability, RL / NL ⁽¹³⁾	%		7.9 / 12.4	7.4 / 11.4
	5.8	Max. gradeability RL / NL ⁽¹³⁾	%		10.3 / 15.7	9.7 / 14.5
	5.9	Acceleration time RL / NL	s		5.1 / 4.6	5.1 / 4.6
	5.10	Service brake			Electric	Electric
	ELECTRIC	6.1	Drive motor S2 60 minute rating	kW		9.6
6.2		Lift motor, S3 15% rating	kW		14	14
6.3		Battery according to DIN 43531 / 35 / 36 A,B,C, no			C	C
6.4		Battery voltage / nominal capacity K5	(V)/(Ah)		48/560 (48/620) ⁽⁶⁾	48/560 (48/620) ⁽⁶⁾
6.5		Battery weight ⁽⁴⁾	lb (kg)		2070 (939) / 2094 (950)	2070 (939) / 2094 (950)
OTHER	8.1	Type of drive unit			AC Controller	AC Controller
	10.1	Operating pressure for attachments	bar		180	180
	10.2	Oil volume for attachment	l/min		20	20
	10.7	Sound pressure level at the driver's seat	dB(A)		<68,6	<68,6 ⁽¹²⁾

⁽¹⁾ With load backrest h 4 + 20 in. (MRO16), + 17.4 in. (MRO20)

⁽²⁾ With beacon and with OHG h6 + 4.73 in. ; otherwise With beacon h6 + 3.74 in.

⁽³⁾ +3.5 in. for FULL CAB configuration OR additional bumper option

⁽⁴⁾ These values may vary of +/- 5%.

⁽⁵⁾ Forks retracted

⁽⁶⁾ Available battery 48V / 620Ah (2094 lb.); Li-ion battery 48V / 460Ah (2070 lb.); Li-ion battery 48V / 540Ah (2064 lb.)

⁽⁷⁾ Values in brackets are Optional

⁽⁸⁾ Side shift stroke is +/-2.95 in. on all trucks

⁽⁹⁾ With OHG Grid Protector h6 + 1.18 in. ; With OHG Screen Protector h6 + 1.77 in.

⁽¹⁰⁾ +3.7 in. for FULL CAB configuration OR additional bumper option

⁽¹¹⁾ With OHG and PAL side line h6 + 5.32 in., With OHG and Double Work Light to Front h6 + 8.66 in.

⁽¹²⁾ With heater SWITCHED ON = 73.8

⁽¹³⁾ Gradeability grades based on motor thermal capacity, torque available and brake requirements

⁽¹⁴⁾ 121.8 in. (MRO16) and 121.9 in. (MRO20) for FULL CAB configuration OR additional bumper option

⁽¹⁵⁾ 123.9 in. (MRO16) and 124.1 in. (MRO20) for FULL CAB configuration OR additional bumper option

⁽¹⁶⁾ 117.5 in. (MRO16) and 117.9 in. (MRO20) for FULL CAB configuration OR additional bumper option

⁽¹⁷⁾ 115 in. (MRO16) and 115.6 in. (MRO20) with additional bumper option

⁽¹⁸⁾ 117.2 in. (MRO16) and 117.3 in. (MRO20) with additional bumper option

⁽¹⁹⁾ 116.8 in. (MRO16) and 117.15 in. (MRO20) for FULL CAB configuration OR additional bumper option

⁽²⁰⁾ 119.2 in. (MRO16) and 119.5 in. (MRO20) for FULL CAB configuration OR additional bumper option

⁽²¹⁾ Data referenced to FULL CAB configuration

⁽²²⁾ 119.9 in. (MRO16) and 120.02 in. (MRO20) with additional bumper option

⁽²³⁾ 122.05 in. (MRO16) and 122.3 in. (MRO20) with additional bumper option

⁽²⁴⁾ 115.85 in. (MRO16) and 116.3 in. (MRO20) with additional bumper option

MRO20A GENERAL SPECIFICATIONS

					Yale	
GENERAL	1.1	Manufacturer (abbreviation)			MRO20A	MRO20A w/ cab
	1.2	Manufacturer's type designation			Electric (battery)	Electric (battery)
	1.3	Drive: electric, diesel, gasoline, LPG			Seated	Seated
	1.4	Operator type			4500 (2.0)	4500 (2.0)
	1.5	Rated capacity / rated load	lb (kg)	Q	24 (600)	24 (600)
	1.6	Load center distance	in (mm)	c	16.30 (414)	14.06 (357)
	1.8	Load distance, center of drive axle to fork	in (mm)	x	58.66 (1490)	58.66 (1490)
	1.9	Wheelbase	in (mm)	y		
	2.1	Service weight	lb (kg)		9090 (4123)	9405 (4266) ⁽²¹⁾
WEIGHT	2.3	Axle loading, NL front / rear ⁽⁵⁾	lb (kg)		5249 / 3840 (2381 / 1742)	5377 / 4028 (2439 / 1827) ⁽²¹⁾
	2.4	Axle loading fork advanced, RL front / rear	lb (kg)		1329/12170 (603 / 5520)	1360 / 12454 (617 / 5649) ⁽²¹⁾
	2.5	Axle loading fork retracted, RL front / rear	lb (kg)		4716 / 8783 (2139 / 3984)	4674 / 9140 (2120 / 4146) ⁽²¹⁾
	3.1	Tires, front / rear (SE=Pneumatic-Solid Shaped)			SE/SE	SE/SE
TIRES	3.2	Tire size, front			200 / 50-10	200 / 50-10
	3.3	Tire size, rear			180 / 60-10	180 / 60-10
	3.5	Wheels, number front / rear (x = driven wheels)			1x/2	1x/2
	3.7	Tread, rear	in (mm)	b ₁₁	48.25 (1225.5)	48.25 (1225.5)
	4.1	Tilt of mast / fork carriage, forward / backward (α / β)	degrees	f / b	2 / 4	2 / 4
	DIMENSIONS	4.2	Height of mast, lowered	in (mm)	h ₁	
4.3		Free lift	in (mm)	h ₂		
4.4		Lift	in (mm)	h ₃		
4.5		Height, mast extended ⁽¹⁾	in (mm)	h ₄		
4.7		Height of overhead guard (cabin) ^{(2) (9) (11)}	in (mm)	h ₆	92.09 (2339)	95.04 (2414)
4.8		Seat height relating to SIP	in (mm)	h ₇	50.94 (1294)	50.94 (1294)
4.10		Height of wheel arms	in (mm)	h ₈	18.54 (471)	18.54 (471)
4.19		Overall length ⁽³⁾	in (mm)	l ₁	99.06 (2516)	101.3 (2573)
4.20		Length to face of forks ⁽³⁾	in (mm)	l ₂	53.78 (1366)	56.02 (1423)
4.21		Overall width	in (mm)	b ₁ / b ₂	49.80 / 55.67 (1265 / 1414)	49.80 / 55.67 (1265 / 1414)
4.22		Fork dimensions DIN ISO 2331	in (mm)	s / e / l	1.6 / 4.7 / 45.3 (40 / 120 / 1150)	1.6 / 4.7 / 45.3 (40 / 120 / 1150)
4.23		Fork carriage ISO 2328, class / type A, B			2A	2A
4.24		Fork carriage width	in (mm)	b ₃	27.56 (700)	27.56 (700)
4.25		Forks spread, min / max ⁽⁸⁾	in (mm)	b ₅	10.24 / 26.77 (260/680)	10.24 / 26.77 (260/680)
4.26		Distance between wheel arms / loading surfaces	in (mm)	b ₄	35.43 (900)	35.43 (900)
4.28		Reach distance	in (mm)	l ₄	25.98 (660)	23.74 (603)
4.31		Ground clearance, RL, below mast	in (mm)	m ₁	3.60 (91.5)	3.60 (91.5)
4.32		Ground clearance, center of wheelbase	in (mm)	m ₂	3.60 (91.5)	3.60 (91.5)
4.34.1		Aisle width for pallets 1000mm × 1200mm crossways (l ₆ × b ₁₂)	in (mm)	Ast	111.85 (2841) ⁽¹⁷⁾	113.46 (2882) ⁽¹⁹⁾
4.34.2		Aisle width for pallets 800mm × 1200mm lengthwise (b ₁₂ × l ₆)	in (mm)	Ast	113.54 (2884) ⁽¹⁸⁾	115.59 (2936) ⁽²⁰⁾
4.34.3		Aisle width for pallets 40" × 48" lengthwise (b ₁₂ × l ₆)	in (mm)	Ast	116.32 (2955) ⁽²²⁾	118.24 (1803) ⁽¹⁴⁾
4.34.4		Aisle width for pallets 48" × 48" (b ₁₂ × l ₆)	in (mm)	Ast	118.60 (3012) ⁽²³⁾	120.41 (3059) ⁽¹⁵⁾
4.34.5		Aisle width for pallets 48" × 40" crossways (b ₁₂ × l ₆)	in (mm)	Ast	112.57 (2859) ⁽²⁴⁾	114.18 (2900) ⁽¹⁶⁾
4.35		Turning radius ⁽¹⁰⁾	in (mm)	W _a	70.96 (1802.5)	70.96 (1802.5)
4.37		Length across wheel arms ⁽⁹⁾	in (mm)	l ₇	79.37 (2016)	79.37 (2016)
4.42		Step height (from ground to running board)	in (mm)		28.11 (714)	28.11 (714)
4.43		Step height (between intermediate steps and floor)	in (mm)		21.06 (535)	21.06 (535)
PERFORMANCE	5.1	Travel speed, RL / NL	mph (km/h)		6.96 / 7.77 (11.2 / 12.5)	7.02 / 7.77 (11.3 / 12.5)
	5.1.1	Travel speed, RL / NL, backwards	mph (km/h)		6.96 / 7.77 (11.2 / 12.5)	7.02 / 7.77 (11.3 / 12.5)
	5.2	Lift speed, RL / NL	ft/min (m/s)		63 / 126 (0.37 / 0.64)	63 / 126 (0.37 / 0.64)
	5.3	Lowering speed, RL / NL	ft/min (m/s)		108.3 / 98.4 (0.55 / 0.50)	108.3 / 98.4 (0.55 / 0.50)
	5.4	Reaching speed, RL / NL	ft/min (m/s)		33.5 / 33.5 (0.17 / 0.17)	33.5 / 33.5 (0.17 / 0.17)
	5.7	Gradeability, RL / NL ⁽¹³⁾	%		6.9 / 11.8	6.7 / 11.4
	5.8	Max. gradeability RL / NL ⁽¹³⁾	%		9.1 / 15	8.8 / 14.4
	5.9	Acceleration time RL / NL	s		5.3 / 4.6	5.1 / 4.6
	5.10	Service brake			Electric	Electric
	ELECTRIC	6.1	Drive motor S2 60 minute rating	kW		9.6
6.2		Lift motor, S3 15% rating	kW		14	14
6.3		Battery according to DIN 43531 / 35 / 36 A,B,C, no			C	C
6.4		Battery voltage / nominal capacity K5	(V)/(Ah)		48/560 (48/620) ⁽⁶⁾	48/560 (48/620) ⁽⁶⁾
6.5		Battery weight ⁽⁶⁾	lb (kg)		2070 (939) / 2094 (950)	2070 (939) / 2094 (950)
OTHER	8.1	Type of drive unit			AC Controller	AC Controller
	10.1	Operating pressure for attachments	bar		180	180
	10.2	Oil volume for attachment	l/min		20	20
	10.7	Sound pressure level at the driver's seat	dB(A)		<68,6	<68,6 ⁽¹²⁾

⁽¹⁾ With load backrest h 4 + 20 in. (MRO16), + 17.4 in. (MRO20)

⁽²⁾ With beacon and with OHG h6 + 4.73 in. ; otherwise With beacon h6 + 3.74 in.

⁽³⁾ +3.5 in. for FULL CAB configuration OR additional bumper option

⁽⁴⁾ These values may vary of +/- 5%.

⁽⁵⁾ Forks retracted

⁽⁶⁾ Available battery 48V / 620Ah (2094 lb.); Li-ion battery 48V / 460Ah (2070 lb.); Li-ion battery 48V / 540Ah (2064 lb.)

⁽⁷⁾ Values in brackets are Optional

⁽⁸⁾ Side shift stroke is +/-2.95 in. on all trucks

⁽⁹⁾ With OHG Grid Protector h6 + 1.18 in. ; With OHG Screen Protector h6 + 1.77 in.

⁽¹⁰⁾ +3.7 in. for FULL CAB configuration OR additional bumper option

⁽¹¹⁾ With OHG and PAL side line h6 + 5.32 in., With OHG and Double Work Light to Front h6 + 8.66 in.

⁽¹²⁾ With heater SWITCHED ON = 73.8

⁽¹³⁾ Gradeability grades based on motor thermal capacity, torque available and brake requirements

⁽¹⁴⁾ 121.8 in. (MRO16) and 121.9 in (MRO20) for FULL CAB configuration OR additional bumper option

⁽¹⁵⁾ 123.9 in. (MRO16) and 124.1 in (MRO20) for FULL CAB configuration OR additional bumper option

⁽¹⁶⁾ 117.5 in. (MRO16) and 117.9 in (MRO20) for FULL CAB configuration OR additional bumper option

⁽¹⁷⁾ 115 in. (MRO16) and 115.6 in. (MRO20) with additional bumper option

⁽¹⁸⁾ 117.2 in. (MRO16) and 117.3 in. (MRO20) with additional bumper option

⁽¹⁹⁾ 116.8 in. (MRO16) and 117.15 in. (MRO20) for FULL CAB configuration OR additional bumper option

⁽²⁰⁾ 119.2 in. (MRO16) and 119.5 in (MRO20) for FULL CAB configuration OR additional bumper option

⁽²¹⁾ Data referenced to FULL CAB configuration

⁽²²⁾ 119.9 in. (MRO16) and 120.02 in. (MRO20) with additional bumper option

⁽²³⁾ 122.05 in. (MRO16) and 122.3 in. (MRO20) with additional bumper option

⁽²⁴⁾ 115.85 in. (MRO16) and 116.3 in. (MRO20) with additional bumper option

3 STAGE FULL FREE LIFT (3500 LBS.) MAST DETAILS

MRO16A	Lift	Free lift	Height of mast, lowered	Height, mast extended
	h ³	h ²	h ¹	h ⁴⁽¹⁾
	in (mm)	in (mm)	in (mm)	in (mm)
	196 (5000)	64 (1648)	88 (2212)	220 (5579.5)
206 (5250)	68 (1734)	91 (2298)	230 (5829.5)	
216 (5500)	71 (1820)	94 (2384)	240 (6079.5)	
226 (5750)	75 (1906)	98 (2470)	250 (6329.5)	
236 (6000)	78 (1992)	101 (2556)	260 (6579.5)	
246 (6250)	81 (2078)	104 (2642)	269 (6829.5)	
255 (6500)	85 (2164)	108 (2728)	279 (7079.5)	
265 (6750)	88 (2250)	111 (2814)	289 (7329.5)	
275 (7000)	92 (2336)	115 (2900)	299 (7579.5)	
285 (7250)	95 (2422)	118 (2986)	309 (7829.5)	
295 (7500)	98 (2508)	121 (3072)	319 (8079.5)	

⁽¹⁾With load backrest 39.37 in. height, h⁴ + 20 in. ; with load backrest 59.06 in. height, h⁴ + 39.69 in. Carriage set at 18.9 in. from the ground.

All values are nominal values and they are subject to tolerances. For further information, please contact the manufacturer. Values may vary with alternative configurations.

STAGE FULL FREE LIFT (4500 LBS.) MAST DETAILS

MRO20A	Lift	Free lift	Height of mast, lowered	Height, mast extended
	h ³	h ²	h ¹	h ⁴⁽¹⁾
	in (mm)	in (mm)	in (mm)	in (mm)
	183 (4650)	62 (1582)	88 (2212)	208 (5279.5)
192 (4900)	65 (1668)	91 (2298)	218 (5529.5)	
202 (5150)	69 (1754)	94 (2384)	228 (5779.5)	
212 (5400)	72 (1840)	98 (2470)	238 (6029.5)	
222 (5650)	75 (1926)	101 (2556)	248 (6279.5)	
232 (5900)	79 (2012)	104 (2642)	258 (6529.5)	
242 (6150)	82 (2098)	108 (2728)	267 (6779.5)	
252 (6400)	86 (2184)	111 (2814)	277 (7029.5)	
261 (6650)	89 (2270)	115 (2900)	287 (7279.5)	
271 (6900)	92 (2356)	118 (2986)	297 (7529.5)	
281 (7150)	96 (2442)	121 (3072)	307 (7779.5)	
291 (7400)	99 (2528)	125 (3158)	317 (8029.5)	

⁽¹⁾With load backrest 39.37 in. height, h⁴ + 17.44 in. ; with load backrest 59.06 in. height, h⁴ + 37.12 in. Carriage set at 18.9 in. from the ground.

All values are nominal values and they are subject to tolerances. For further information, please contact the manufacturer. Values may vary with alternative configurations.

TRUCK DIMENSIONS FOR BATTERIES

TRUCK MODEL	Compartment dimensions-max.			Battery dimensions-max.			Volts	No. of cells	Amp Hr Capacity range	Weight	
	Width	Length	Height	X	Y	Z				Min	Max
	in (mm)	in (mm)	in (mm)	in (mm)	in (mm)	in (mm)				lb (kg)	lb (kg)
				+0"/-0.12" (+0/-3)	+0"/-0.12" (+0/-3)	+0"/-0.08" (+0/-2)					
MRO16A (3,500lb)	48.15 (1223)	14.09 (358)	30.94 (786)	48.11 (1222)	13.98 (355)	30.87 (784)	48	24	560-620	1967 (892)	2200 (998)
MRO20A (4,500lb)	48.15 (1223)	14.09 (358)	30.94 (786)	48.11 (1222)	13.98 (355)	30.87 (784)	48	24	560-620	1967 (892)	2200 (998)

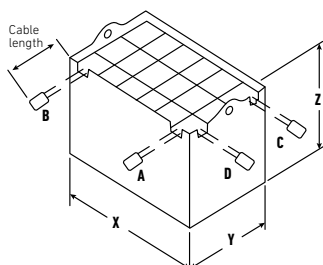

Battery compartment length is measured from front to rear.
 Battery compartment width is measured across the truck.
 Battery connector: 350 amp/48 volt (SB350 blue)
 Battery lead: length 31.5" (800 mm) "A" position.
 Battery cover - not needed

FEATURES LIST

PERFORMANCE	STD	OPT
7.8mph travel speed	●	
High speed lift	●	
Laser line fork positioning		●
Auto center sideshift		●
Auto fork leveling in the horizontal position		●
Height pre-selector (with/without pallet detection device)		●
Fork camera		●
Load backrest mounted color camera		●
Inner mast camera and monitor		●
Load weight indicator		●
Creep speed		●
DRIVE	STD	OPT
Park brake (spring applied, electrically released)	●	
Top/front load wheel protection	●	
Super elastic load wheels and drive tire	●	
Non-marking super elastic load wheels		●
Non-marking super elastic drive tire		●
LIFT	STD	OPT
3-stage mast/tilting carriage with integral sideshift	●	
Lift limit with override (1× or 2× height setting)		●
Lower limit (with override option)		●
Telescoping forks		●
Side shifting fork positioner		●
HANDLING	STD	OPT
Accutouch mini-levers hydraulic controls	●	
45" long × 1.4" thick × 4.7" wide – hook type – standard taper forks (MRO16A)	●	
45" long × 1.6" thick × 4.7" wide – hook type – standard taper forks (MRO20A)	●	
Simultaneous hydraulics – lift / reach functionality	●	
Simultaneous hydraulics – all hydraulics		●
Joystick controls hydraulic controls		●
Lift Comfort package		●
Various fork lengths		●
ERGONOMICS	STD	OPT
Intermediate step	●	
Grab handle on overhead guard and under armrest	●	
Adjustable length armrest	●	
Full suspension seat - cloth (2 in suspension travel)	●	
Standard display	●	
Adjustable steering column	●	
Premium touch screen display		●
Full suspension seat (3 in suspension travel)		●
Headrest		●
Heated seat		●
Anti-static seat		●
Vinyl seat upholstery		●
Work lights ×1 (driver side)		●
Work lights ×2 (mast side)		●
Work lights ×2 (driver side)		●
Carriage mounted work lights		●
Panoramic mirror		●

OPERATION	STD	OPT
180 degree steering	●	
Key switch	●	
4 function hydraulics	●	
92" standard overhead guard	●	
Operator shield (transparent)	●	
Operator shield (wire mesh)		●
Keyless access		●
360 degree steering		●
Driver select steering mode 180/360 degree steering (push button)		●
5th hydraulic function		●
Universal support bracket		●
RF terminal mount		●
Beverage holder and document tray		●
Clipboard		●
Stretch film roll holder		●
Polycarbonate (lexan) protection on top overhead guard (without cab)		●
Metal grid protection on top overhead guard (without cab)		●
Full view overhead guard top		●
Rear/top screens with rear wipers		●
Rear/top/side screens with rear wipers		●
Additional bumper (standard on full cab)		●
Full cab with wipers		●
Side battery change - battery tray rollers		●
Drip rail		●
Load backrest (39.4" (1000mm) / 59" (1500mm))		●
DC/DC converter (12V/48V, 24V/48V, or 12-24V/48V)		●
Amber strobe		●
Audible alarm (choice of forks leading, forks trailing, both travel directions)		●
Pedestrian awareness lights (spotlight chassis direction – forks trailing)		●
Pedestrian awareness lights (red side line lights)		●
Yale Vision		●
CONSTRUCTION	STD	OPT
Standard construction	●	
High temperature environment – (temperature > 95 deg F)		●
ENERGY SYSTEM	STD	OPT
Lead Acid battery	●	
Power Key		●
SUPPLEMENTAL	STD	OPT
Operating manual	●	

† NOTE: Performance specifications/ratings are for truck equipped as described under Standard Equipment in this Specification Sheet. Performance specifications are affected by the condition of the vehicle and how it is equipped, as well as by the nature and condition of the operating area. Specifications are subject to change and the proposed application should be discussed with your authorized Yale® dealer.

†† All values are nominal values and are subject to tolerances. For further information on this dimension, please contact your local Yale® dealer.

††† Values may vary with alternative configurations.

Above specifications, unless otherwise listed, are for a standard truck without optional equipment. See truck dimensions for batteries chart.

RL = Rated Load, NL = No Load

About Yale



Yale Lift Truck Technologies leverages over a century of material handling experience and substantial investment in innovation to bring the most advanced technology-driven lift truck solutions to market. The company offers a full line of award-winning lift trucks, including reach trucks, order pickers, turret trucks, pallet jacks and trucks, pallet stackers, tow tractors and counterbalanced forklifts, as well as powerful operator assist solutions, proven robotics and a wide range of power sources to help customers adapt to today's demanding supply chain. Yale and its independent dealer network support these solutions with comprehensive after-sales service, parts, financing and training.

MATERIALS HANDLING FOR:

Third-party logistics (3PL)

Auto parts distribution

Beverage

Cold & frozen foods

Food distribution

Food processing

Furniture & furnishings

Government

Health & pharma

Home centers & durables

Retail & e-commerce

Yale Lift Truck Technologies
P.O. Box 7367
Greenville, NC 27835-7367
U.S.A.

yale.com

© 2025 Hyster-Yale Materials Handling, Inc., all rights reserved. YALE and  are trademarks of Hyster-Yale Materials Handling, Inc.

Trucks may be shown with optional equipment and/or features not available in all regions. Truck performance may be affected by the condition of the vehicle, how it is equipped and the application. Specifications are subject to change without notice. Consult your Yale® Dealer if any of the information shown is critical to your application.

CERTIFICATION: Yale lift trucks meet the design and construction requirements of B56.1-1969, per OSHA Section 1910.178(a)(2), and also comply with the B56.1 revision in effect at time of manufacture. Classified by Underwriters' Laboratories, Inc.