

# MTA 120UX

---

Sit-down  
tow tractor

12,000 lbs.



# MTA120UX features

The Yale® MTA120UX sit-down tow tractor combines ergonomic features, reliable technology and energy efficient performance in a cost-effective package for less-demanding applications. Backed by the Yale brand and nationwide dealer network, businesses can count on the UX Series electric tow tractor for reliable operation and low maintenance requirements to help boost productivity and reduce operational costs.



**ERGONOMIC OPERATOR COMPARTMENT**



**EASY SERVICE ACCESS VIA BACK COVER**

## PRODUCTIVITY

- High-power, maintenance free AC drive motor
- Impressive pulling performance
- Seamless travel and maneuverability
- 3 operation modes available
- Ergonomic layout to help maximize efficiency and comfort
- Adjustable seat and steering column
- Rear, multi-position tow coupling
- Multi-function LCD dash display

## SERVICEABILITY

- Easy access for fast and efficient servicing
- Simple, readily available components
- CANbus technology helps reduce wiring complexity
- Built-in diagnostics accessible via the dash display
- Computer-based diagnostics not required

## SAFETY AND STRUCTURAL DESIGN

- Operator Presence System (OPS)
- Non-slip, uncluttered floor plate
- Drive axle design and low center of gravity helps maximize stability
- Emergency stop button
- High quality, robust components
- Low noise level
- Seatbelt

## OPTIONAL FEATURES

- Power steering
- Automatic electro-magnetic parking brake
- Seatbelt reminder system
- Semi-closed cabin
- Dual side view mirrors
- Non-marking tires
- Blue light and strobe light
- Keyless key switch (password)

## GENERAL SPECIFICATIONS - MTA120UX

GENERAL

1	Power type		48-volt
2	Operator type		Seated
3	Rated capacity	lb. (kg)	13227 (6000)
4	Drawbar pull, 60min rating	lbf (N)	337.2 (1500)
5	Max drawbar pull, 5min rating	lbf (N)	1348.85 (6000)
6	Wheelbase	in. (mm)	50.39 (1280)
7	Rear load distance	in. (mm)	19.68 (500)
8	Service weight	lb. (kg)	2998.2 (1360)
9	Axle loading, unladen front / rear	lb. (kg)	992 (450) / 2006.2 (910)
10	Front, tire size / type (no. of wheels)		15 x 4.5 Solid (1)
11	Rear, tire size / type (no. of wheels)		4.00 - 8 Solid (2)
12	Wheel tread, front	in. (mm)	n/a
13	Wheel tread, rear	in. (mm)	37.24 (946)
14	Seat height / STD	in. (mm)	35.83 (910)
15a	Coupling height	in. (mm)	11.61 (295)
15b			14.56 (370)
15c			17.32 (440)
16	Overall length	in. (mm)	78.54 (1995)
17	Overall width	in. (mm)	43.3 (1100)
18	Overall height (excluding cab)		50.39 (1280)
19	Approach angle	deg (°)	≥45
20	Departure angle	deg (°)	≥40
21	Min ground clearance	in. (mm)	3.54 (90)
22	Turning radius	in. (mm)	64.96 (1650)
23	Travel speed, unladen	mph (km/h)	9 (14.5)
24	Travel speed, laden	mph (km/h)	4.97 (8)
25	Gradeability, laden / unladen	%	7 / 15
26	Service brake / parking brake		hydraulic / manual
27	Drive control		AC
28	Drive motor rating *S2 60 min	hp (kW)	7.5 (5.6)
29	Steering motor rating *S2 5 min (option)	hp (kW)	0.8 (0.6)
30	Battery ampere hours	Ah	400
31	Battery weight	lb. (kg)	1499 (680)
32	Sound level at the drivers ear according to EN/DIN 12 053	dB (A)	<68

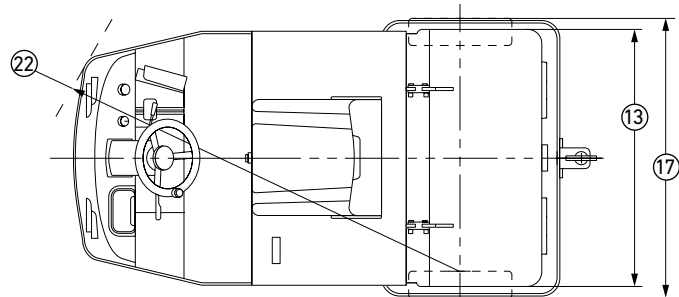
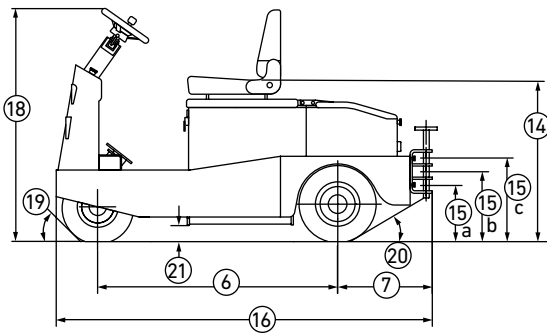

Circled truck dimensions correspond to the line numbers in the General Specifications chart. Dimensions are listed in inches (millimeters.)

# About Yale

Yale Lift Truck Technologies leverages over a century of material handling experience and substantial investment in innovation to bring the most advanced technology-driven lift truck solutions to market. The company offers a full line of award-winning lift trucks, including reach trucks, order pickers, turret trucks, pallet jacks and trucks, pallet stackers, tow tractors and counterbalanced forklifts, as well as powerful operator assist solutions, proven robotics and a wide range of power sources to help customers adapt to today's demanding supply chain. Yale and its independent dealer network support these solutions with comprehensive after-sales service, parts, financing and training.



Yale Lift Truck Technologies  
P.O. Box 7367  
Greenville, NC 27835-7367  
U.S.A.

**yale.com**



EXPLORE MORE  
ONLINE.



## MATERIALS HANDLING FOR:

Third-party logistics (3PL)

Auto parts distribution

Beverage

Cold & frozen foods

Food distribution

Food processing

Furniture & furnishings

Government

Health & pharma

Home centers & durables

Retail & e-commerce

© 2023 Hyster-Yale Group, Inc., all rights reserved. YALE and  are trademarks of Hyster-Yale Group, Inc.

Trucks may be shown with optional equipment and/or features not available in all regions. Truck performance may be affected by the condition of the vehicle, how it is equipped and the application. Specifications are subject to change without notice. Consult your Yale® Dealer if any of the information shown is critical to your application.

CERTIFICATION: Yale lift trucks meet the design and construction requirements of B56.1-1969, per OSHA Section 1910.178(a)(2), and also comply with the B56.9 revision in effect at time of manufacture.